

Manufacture



de Buyer
D E P U I S 1 8 3 0

Chaque recette a son secret*

COLLECTION 2021



French Manufacture of
cooking and pastry utensils

191 years of history

1830

2021

Le Val d'Ajol
Vosges (88)



25 000 m²

2 500 products
49 patents



180 employees

OUR KNOW-HOWS



INNOVATION



FRENCH DESIGN AND
MANUFACTURING



CRAFTSMANSHIP AND
INDUSTRIAL KNOW-HOW



CONTROL OF MATERIALS

International presence
94 COUNTRIES



CSR commitment



Local roots • Respect for the environment • Welfare at work



Labelled
« Entreprise du patrimoine Vivant »





Dear partners,

2020 has shown that being adaptable is truly the key to success. We are here to help with stocking up on utensils to satisfy new hygiene standards, setting up an effective takeaway service and meeting the needs of individuals requiring professional quality at your outlet.

de Buyer's wide-ranging products give you everything you need to adapt to changing consumer demands in the professional and amateur spaces.

In 2021, we are ramping up our efforts to help you educate and inform consumers, develop your outlet, and offer relevant content in-store and online.

This year, more than ever before, we are here to help your best recipe become a successful triumph.

We are honoured by your trust in us over the past 190+ years.

Kind regards,

Guilhem Pinault

NEW PRODUCTS



STAINLESS
STEEL

ALCHIMY page 61



LE TUBE PRO
page 143

NONSTICK



CHOC INTENSE removable line
page 76



#OUTDOOR page 23

Plancha griddle
Blue steel pan
Utensils BBQ



MILLS



RUMBA wooden mill 18 cm
page 104

JOIN US AT THE **SIRHA** SHOW IN LYON FROM MAY 29 TO JUNE 2

HAVING SUPPORTED THE FRANCE TEAM IN 2019, DE BUYER, OFFICIAL PARTNER IN THE GRAND FINAL OF THE

BOCUSE D'OR

01 | 02 JUNE 2021 – LYON





BOOST YOUR SALES AND DEVELOP YOUR STORE: GO THROUGH THE TRAINING AND MASTERCLASS CATALOGUE DOWNLOAD :



TOOLS AVAILABLE FOR IN-STORE PROMOTIONS:

- DEDICATED PACKAGING •
- RECIPES •
- BACKGROUND VISUALS •
- DIGITAL KITS •



PASTRY



Perforated stainless steel pastry moulds pages 175-176

CATERING SPECIAL OFFER

Product selections available for every need :



THE BOX



#crepesparty
#steaklover
#brunchtime
pages 6-7

#homemadebread
#homebaking
pages 170-171



NEW WEB SITE AND BLOG

DEBUYER.COM

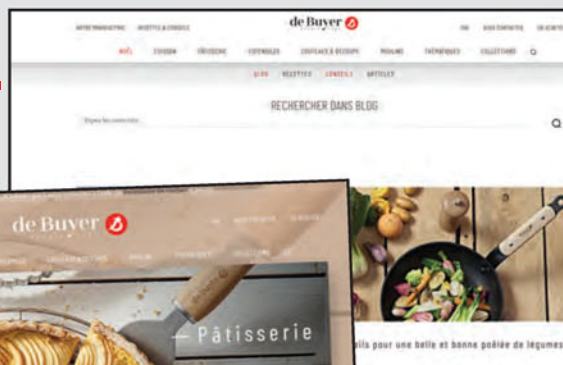

Recipes, tips, advice, info and real-life experiences to meet all your expectations and needs

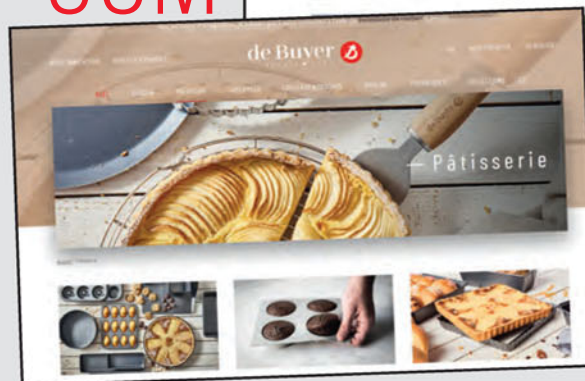



STEEL THAT STANDS THE TEST OF TIME

Steel frying pans are what our grandmothers used to use. These timeless pans are ideal for high-temperature cooking and take a simple and natural approach without any additional coating. We protect and nourish them with beeswax - it is then up to you to season your pan so it can truly flourish.

- 9 -

Steel & beeswax
MINERAL B

- 17 -

Steel CARBONE PLUS

- 20 -

Blue steel LA LYONNAISE

- 26 -

Blue steel #OUTDOOR





Box #crepesparty

BOX #crepesparty

new 2021



Code	Designation	Lcm	Wcm	Hcm
5615.01		47,5	30	10

Composition :

- Steel crepe pan MINERAL B ø26 cm, beeswax finish and strip steel handle
- Beechwood crepe spatula
- Silicone pastry brush



Box #steaklover

BOX Steak Lover



Code	Designation	Lcm	Wcm	Hcm	Kg
5610.03		47,5	30	10	2,85

- Composition :
- Steel frying pan MINERAL B ø26 cm, beeswax finish and strip steel handle
 - Pepper mill, beechwood with steel mechanism
 - Stainless steel tong L.24cm

Box #brunchtime

BOX #BRUNCHTIME Pancakes & Blinis



Code	Designation	Lcm	Wcm	Hcm	Kg
5612.01		47,5	30	10	1,93

- Composition :
- 3-Blini pan MINERAL B made of steel, beeswax finish and steel handle - for 3 blinis ø10 cm
 - Ladle made of stainless steel and beechwood
 - Beechwood crepe spatula

THE WHITES

THE BLUES

MINERAL B
· PRO ·

MINERAL B
· BOIS ·

MINERAL B

CarbonePlus

OUTDOOR

La Lyonnaise

Collection

Material of the
body of the pan

White steel sheet

Blued steel sheet

Thickness

2,5 to 3 mm

2 mm

1 to 1,5 mm

Cooking methods

Searing / Grilling / Browning

Designed for cooking



Finish

Natural beeswax protection



Lightly oiled

Heat sources



Moderate

Type of curved
French-style handle

Steel strip and
wood handle

Steel strip handle

Fixing of the handle
or base

Cast stainless steel
handle



Riveted +
heat stop

Riveted

Spot welded

Use in the oven



Flash heat :
10 minutes at 200 °C

Dishwasher cleaning

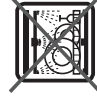

Profile

Flared and rounded lyonnaise shape : facilitates turning of foods

Diameter (cm)

20 to 32

12 to 40

12 to 50

12 to 36

14 to 45

Guarantee

Lifetime

PCB (packaging unit)

1

1

1

3 - 5

3

10

STEEL PAN WITH BEESWAX FINISH

- NATURAL ANTI-OXIDATION PROTECTION
- FAVOURED SEASONING
- IMPROVED NONSTICK QUALITIES

Robust : from 2,5 to 3 mm thick
 RIVETED CAST STAINLESS STEEL HANDLE
 possible oven cooking

Made in France

Suitable for all hotplates including INDUCTION

MINERAL B · PRO ·



Round frypan MINERAL B PRO with cast st/steel handle

Code	Designation	Øcm	Hcm	Th.mm	Bottom ø cm	Kg
5680.20		20	3,3	2,5	14	1,09
5680.24		24	3,5	2,5	17,5	1,44
5680.28		28	4	3	21	2,17
5680.32	With 2 handles	32	4,5	3	23	2,9



MINERAL B STEEL PAN WITH BEESWAX FINISH
 riveted cast stainless steel handle
 Robust : from 2,5 to 3 mm thick. Undistortable.
 Suitable for all hotplates including INDUCTION and oven cooking



Round deep country pan MINERAL B Pro with cast st/steel handle

Code	Designation	Øcm	Hcm	Liters.	Th.mm	Kg
5684.28		28	8,7	4	2,5	2,49



STEEL PAN B BOIS WITH BEESWAX FINISH

- NATURAL ANTI-OXIDATION PROTECTION
- FAVOURED SEASONING
- IMPROVED NONSTICK QUALITIES

Robust : from 2,5 to 3 mm thick

Riveted handle made of steel and beechwood - Possible oven cooking 10 minutes / 200°C

The beech wood used is a wood coming from sustainably managed forests.

Suitable for all hotplates including INDUCTION

Made in France

'B Bois' products are exclusively sold via physical retailers.

MINERAL B BOIS



Round frying pan MINERAL B BOIS



Code	Designation	Øcm	Hcm	Th.mm	Bottom ø cm	Kg
5710.20		20	3,2	2,5	14	1,05
5710.24		24	3,5	2,5	17,5	1,41
5710.26		26	4	3	18,5	1,93
5710.28		28	4	3	21	2,18
5710.32	with 2 handles	32	4,5	3	23	2,66

Round deep country pan MINERAL B BOIS



Code	Designation	Øcm	Lcm	Hcm	Liters.	Th.mm	ø bottom cm	Kg
5714.24		24	45,6	7,7	2,5	2,5	16,5	1,88

Round crepe pan MINERAL B BOIS



Code	Designation	Øcm	Lcm	Hcm	Th.mm	Kg
5715.24		24	45,5	1,2	2,5	1,2

3-blini pan MINERAL B BOIS



Code	Designation	Øcm	Th.mm	Kg
5712.03	3 blinis ø 10 cm	27	2	1,2

Wok MINERAL B BOIS



Code	Designation	Øcm	Lcm	Hcm	Th.mm	Kg
5718.28	wok - Base ø 8 cm - With 2 handles	28	50,4	9	2	1,76
5718.32	wok - Base ø 8 cm - With 2 handles	32	60,5	9,7	2	2,18
3329.10	Grid for wok ø 32 cm		34,5			0,14

The wok has forever been the universal Asian kitchen utensil, and it turns out to be ideal for a natural, dietetic cuisine, which needs very little fat and preserves the food's original taste. The 2mm (14 gauge) thickness provides a barrier against increasingly powerful heat sources and thus guarantees an easy-to-digest cuisine.

Glass lid with beechwood knob



Code	Designation	Øcm	Hcm	Kg
4111.20		20	7,5	0,4
4111.24		24	7,5	0,53
4111.28		28	7,5	0,7
4111.32		32	7,5	1

Suits on woks and country pans MINERAL B.



STEEL PAN WITH BEESWAX FINISH

- NATURAL ANTI-OXIDATION PROTECTION
- FAVOURED SEASONING
- IMPROVED NONSTICK QUALITIES

Robust : from 2,5 to 3 mm thick

RIVETED STEEL HANDLE

For pan with steel handle:

possible oven cooking 10 minutes / 200°C

Made in France

Suitable for all hotplates including INDUCTION

MINERAL B



Round frying pan MINERAL B

Code	Designation	Øcm	Hcm	Th.mm	Bottom ø cm	Kg
5610.20		20	3,3	2,5	14	1
5610.24		24	3,5	2,5	17,5	1,39
5610.26		26	4	3	18,5	1,9
5610.28		28	4	3	21	2,15
5610.32	WTH 2 HANDLES	32	4,5	3	23	2,63
5610.36	WTH 2 HANDLES	36	5	3	26	3,53



Steel steak frypan, flared edge MINERAL B

Code	Designation	Øcm	Th.mm	Bottom ø cm	Kg
5616.24		24	2,5	18	1,27
5616.28		28	2,5	21,3	1,63



Round frying pan "GRILL" MINERAL B

Code	Designation	Øcm	Hcm	Th.mm	Bottom ø cm	Kg
5613.26		26	4	2,5	18,5	1,37
5613.32		32	4,5	2,5	23	2,31



Round deep country pan MINERAL B



Code	Designation	Øcm	Hcm	Liters.	Th.mm	Bottom ø cm	Kg
5614.24		24	7,8	2,5	2,5	16,5	1,85
5614.28		28	8,7	4	2,5	19,5	2,47
5614.32	WTH 2 HANDLES	32	9,6	5,5	2,5	22,5	3



Round deep country pan MINERAL B with 2 handles

Code	Designation	Øcm	Hcm	Liters.	Th.mm	Bottom ø cm	Kg
5654.24		24	7,8	2,5	2,5	16,5	1
5654.28		28	8,7	4	2,5	19,5	1,8
5654.32		32	9,6	5,5	2,5	22,5	2,26





Wok MINERAL B



Code	Designation	Øcm	Lcm	Hcm	Th.mm	Kg
5618.24	wok - Base ø 8 cm	24	43,7	8	2	1,4
5618.28	wok - Base ø 8 cm	28	50,4	9	2	1,76
5618.32	wok - Base ø 8 cm - With 2 handles	32	60,5	9,7	2	2
3329.10	Grid for wok ø 32 cm		34,5			0,14
5618.40	wok - Base ø 11 cm- With 2 handles	40	69	10,4	2	2,75

The wok has forever been the universal Asian kitchen utensil, and it turns out to be ideal for a natural, dietetic cuisine, which needs very little fat and preserves the food's original taste. The 2mm (14 gauge) thickness provides a barrier against increasingly powerful heat sources and thus guarantees an easy-to-digest cuisine.

Wok MINERAL B with 2 handles



Code	Designation	Øcm	Lcm	Hcm	Kg
5619.28		28		9	1,75
5619.32		32		9,7	2
3329.10	Grid for wok ø 32 cm		34,5		0,14

The wok has forever been the universal Asian kitchen utensil, and it turns out to be ideal for a natural, dietetic cuisine, which needs very little fat and preserves the food's original taste. The 2mm (14 gauge) thickness provides a barrier against increasingly powerful heat sources and thus guarantees an easy-to-digest cuisine.

Glass lid with stainless steel knob



Code	Designation	Øcm	Kg
3429.14		14	0,24
3429.16		16	0,29
3429.18		18	0,35
3429.20		20	0,41
3429.24		24	0,58
3429.28		28	0,74
3429.32		32	1,1
3429.40		40	1,37

Omelette pan MINERAL B



Code	Designation	Øcm	Hcm	Kg
5611.24		24	3,8	1,35

OMELETTE pan with rounded shape to return easily omelettes and to slide them onto a plate without any problem. Perfect for delicious omelettes, crispy outside and soft inside.



Paella pan MINERAL B with 2 st/steel riveted handles



Code	Designation	Øcm	Hcm	Th.mm	Bottom ø cm	Kg
5652.32	4 p.	32	4,2	3	23	2,5

Round crepe pan MINERAL B



Code	Designation	Øcm	Lcm	Hcm	Th.mm	Bottom ø cm	Kg
5615.24		24	45,5	1,2	2,5	21	1,13
5615.26		26	47,8	1,3	2,5	22,5	1,33
5615.30		30	54,1	1,5	2,5	25,5	1,78

Blinis pan MINERAL B ELEMENT



Code	Designation	Øcm	Lcm	Hcm	Th.mm	Bottom ø cm	Kg	PU
5612.12		12	24,1	1,8	2,5	9,5	0,43	5

3-blini pan MINERAL B



Code	Designation	Øcm	Th.mm	Kg
5612.03	3 blinis ø 10 cm	27	2	1,11



Pan for Poffertjes and mini-blinis MINERAL B



Code	Designation	Øcm	Lcm	Kg
5612.16		27	47,8	1,1

The Poffertjes pan to cook the famous Dutch mini-pancakes or also mini- blinis. 16 Poffertjes ø 4 cm

Rectangular grill pan with 2 st/steel riveted handles



Code	Designation	Lcm	Wcm	Hcm	Kg
5640.02		38	26	2,5	2,49

Born of the famous healthy and dietetic cooking method, the "plancha" is really practical to cook meat thanks to its wide area. Suitable on all heat sources and hot coals.

Rectangular pan PLANCHA, 2 aluminium riveted handles



Code	Designation	Lcm	Wcm	Hcm	Th.mm	Kg
5640.01		38	26	2,5	2,5	2,21

This "Plancha" pan is used to grill meat oven cooking and hotcoals. It is also perfect to cook scallop flesh, shrimps, fish, vegetables..The strong straight aluminium handles are firmly riveted. All heat sources including induction,

Oval roasting-pan with 2 st/steel riveted handles



Code	Designation	Lcm	Wcm	Hcm	Th.mm	Bottom ø cm	Kg
5651.36		36	24	4,8	2,5	21	2,26

STEEL pan

2,5 to 3 mm thick for professional strong heat sources
 Perfect heat conduction
 Extra-strong handle
 For pan with steel handle:
 possible oven cooking 10 minutes / 200°C
 Made in France

Perfect for searing, frying, browning

Carbone Plus



Round "lyonnaise" frypan - Heavy quality steel



Code	Designation	Øcm	Lcm	Hcm	Th.mm	Bottom ø cm	Kg	PU
5110.18		18	35,1	3	2,5	12	0,89	3
5110.20		20	36,8	3,2	2,5	14	1,03	3
5110.22		22	42	4	2,5	15,5	1,24	3
5110.24		24	44	3,5	2,5	17,5	1,31	3
5110.26		26	48,5	4	3	18,5	1,93	3
5110.28		28	50,5	4	3	20	2,1	3
5110.30		30	54	4,2	3	21,5	2,35	3
5110.32	With 2 handles	32	60	4,5	3	23	2,71	3
5110.36	With 2 handles	34	69,5	4,5	3	26	3,5	3
5110.40	With 2 handles	38	73	5,3	3	30	4,11	3
5110.50	With 2 handles	48	91	5,7	3	41	6,13	1

The "lyonnaise" profile pan has a high flared and curved skirt. This very distinctive shape, with no sharp angles, enables the food to slide easily from the frying pan onto a plate or dish. The strip steel handle is firmly riveted.
 All heat sources.
 Possible oven cooking : 10 minutes at 200°C.

Round frying pan - Stainless steel cold handle



Code	Designation	Øcm	Lcm	Hcm	Th.mm	Bottom ø cm	Kg	PU
5130.20		20	36,6	3,2	2,5	14	1	3
5130.24		24	43,7	3,5	2,5	17,5	1,39	3
5130.28		28	51	4	3	20	2,12	3
5130.32	With 2 handles	32	59,6	4,5	3	23	2,71	3

Ergonomic functional stainless tube handle, guaranteed not to heat up and firmly riveted. All hotplates including INDUCTION. Suitable for oven cooking. The "lyonnaise" profile pan has a high flared and curved skirt. This very distinctive shape, with no sharp angles, enables the food to slide easily from the frying pan onto a plate or dish.

Fish frypan - Heavy quality steel



Code	Designation	Lcm	Wcm	Hcm	Th.mm	Bottom ø cm	Kg	PU
5111.36	Oval - total L : 60 cm	36	26	4	2,5	21	2,3	3
5111.40	Oval - total L : 69,5 cm	40	28	5	3	23	3,32	3

Oval and oblong frying pans are the ideal shape for cooking whole fish. Note: the standard model has the handle riveted lengthways.

Oval fish frying pan, steel



Code	Designation	Lcm	Wcm	Hcm	Th.mm	Bottom ø cm	Kg	PU
5131.36	total L.50,3 cm	36	26	4,6	2,5	21	2,39	3

Handle is riveted on the short axis for "salamander special" model. All hotplates including INDUCTION

Pancake pans - Heavy quality steel



Code	Designation	Øcm	Lcm	Hcm	Th.mm	Bottom ø cm	Kg	PU
5120.18	2,5 mm th	18	36,2	1,1	2,5	15	0,71	5
5120.20	2,5 mm th	20	38,4	1,1	2,5	17	0,83	5
5120.22	2,5 mm th	22	42,2	1,3	2,5	19	1,02	5
5120.24	2,5 mm th	24	44,2	1,3	2,5	21	1,14	5
5120.26	2,5 mm th	26	50,2	1,3	2,5	22,5	1,37	5
GIANT CREPE PAN								
5120.30	2,5 mm th	30	54,2	1,7	2,5	25,5	1,79	5

Steel plate is the ideal metal for making crispy, tasty crepes. The low skirt of the frying pan allows crepes to be easily flipped and turned. The handle is welded (except for ø 30 cm whose handle is riveted)

Steel blinis pan - Heavy quality steel



Code	Designation	Øcm	Lcm	Wcm	Hcm	Th.mm	Perso	Kg	PU
5140.12	Blinis pan - 2,5 mm th	12	24	12,2	2	2,5	9,5	0,41	10
5141.03	3 blinis ø 10 cm	27	48		1,2	2		1,11	3

These frying pans allow you to make the well known Russian specialty blinis as well as fritters and pancakes.



Round frypan, 2 stainless steel handles - Heavy quality steel



Code	Designation	Øcm	Hcm	Th.mm	Bottom ø cm	Kg	PU
5113.24	2,5 mm th	24	4	2,5	17,5	1,2	3
5113.28	3 mm th	28	4,5	3	20	1,9	3
5113.32	3 mm th	32	5,5	3	23	2,4	3
5113.36	3 mm th	36	6	3	26	3	3
5113.40	3 mm th	40	6	3	30	3,78	3
5113.50	3 mm th	50	6	3	41	5,82	1

This extra-thick professional frying pan has two firmly welded handles. It has many different uses and proves ideal for paella because of its highly-flared shape, allowing liquid to evaporate quickly (boiling down).

Its heavy-gauge thickness allows food to simmer.

WOK made of iron steel - Special induction cooker



Code	Designation	Øcm	Lcm	Hcm	Th.mm	Kg	PU
5114.35	Polished finishing	35	60,5	8,5	1,5	1,46	3
3122.00		24		3,65	1	0,25	1

Typical Asian rounded form adapted to the wok induction cooker. Enables to seal and cook food with little fat for a dietetic and natural Asian cuisine. Optimized weight of the wok to cook effortless. Thanks to the thickness of 15/10° the wok is both solid and light to handle. Riveted steel handle. Guaranteed without coating.

support, the wok is steady on the plate.

The wok holder is suitable for rounded woks 3122.90 and 5114.35. Enables to use these woks on standard flat induction hotplates. Thanks of the special form with its handle

Round "Grill" frypan with steel handle



Code	Designation	Øcm	Lcm	Hcm	Th.mm	Bottom ø cm	Kg	PU
5530.26		26	48	4,3	2,5	18,5	1,42	3
5530.30		30	54	4,5	2,5	21,5	1,74	3

Ideal for searing meats using hardly any fat. The steel pan reaches high temperatures, caramelizing the meat juices to give your grilled meats flawless flavour. The ribbed base marks the meat and reduces the contact

area between pan and meat. The high side helps prevent from spatters. The thickness of the pan together with the ribbed base prevent shape loss.



Rectangular grill pan



Code	Designation	Lcm	Wcm	Th.mm	Kg	PU
5540.38		38	26	2,5	2,52	3

It is the perfect product for healthy cooking. Without fat, you will obtain really tender and grilled meat.

Rounded steel deep-fryer without basket



Code	Designation	Øcm	Lcm	Hcm	Liters.	Th.mm	Kg
5050.28		28	33,8	8	4	1,2	1,01
5050.32		32	38,9	9,3	6	1,2	1,29
5050.36		36	39,8	10,5	8,8	1,5	2,25
5050.40		40	42,5	13,1	12,2	1,5	2,86
5050.45		45	45,3	14,5	17,3	1,5	3,42
5050.50		50	50,3	16,4	23,5	1,5	4,35

Steel plate, being a very good spreader of heat, is perfect for the manufacture of deep frying vessels. This is the indispensable "SOS" utensil when the electric fryer breaks down. It's also very useful for other unforeseen uses.

Don't forget to order the corresponding frying basket separately.

Tinned wire basket for ref. 5050



Code	Designation	Øcm	Hcm	Kg
5051.28N (1)		25,3	6,3	0,17
5051.32N (1)		29,5	8,7	0,25
5051.36N (1)		32,6	9,3	0,26
5051.40N (2)		39	12,4	0,5
5051.45N (2)		43	15	0,69
5051.50N (2)		46,5	17	0,74

You can set the basket handles on the raised handles of the deep fryer so the cooking oil drains away perfectly. Make sure the basket is clear of the oil.

gaps. Mesh 8x 8 mm.

The basket is close-woven to ensure no food falls through the

La Lyonnaise



BLUE STEEL

1 to 1,5 mm thick for less powerful heat sources
 Semi-professional and domestic use
 Quick heating time
 Extra-strong handles- Welded
 For pan with steel handle:
 possible oven cooking 10 minutes / 200°C

For all heat sources except induction
 Made in France

Round "lyonnaise" frypan, blue steel



Code	Designation	Øcm	Lcm	Hcm	Th.mm	Kg	PU
5020.14	1 mm th	14	26,2	3,3	1	0,25	10
5020.18	1 mm th	18	34,9	3,6	1	0,38	10
5020.20	1 mm th	20	36,9	4	1	0,46	10
5020.24	1 mm th	24	41,2	4,5	1	0,6	10
5020.26	1 mm th	26	46,3	4,5	1	0,69	10
5020.28	1,2 mm th	28	49,3	4,7	1,2	0,93	10
5020.30	1,2 mm th	30	54,4	5	1,2	1,04	10
5020.32	1,2 mm th	32	55,5	5,5	1,2	1,15	5
5020.36	1,5 mm th	36	65,8	6	1,5	1,72	5
5020.40	1,5 mm th	40	69,1	6,5	1,5	2,09	5
5020.45	1,5 mm th	45	83,2	7,5	1,5	2,81	1

The "Lyonnaise" is the traditional "granny-style" frying pan. The lightweight blue steel plate is suitable for low-power heat sources. This "lyonnaise" profile pan has a high flared and curved skirt, with no sharp angles, enabling the food to slide easily from the frying pan onto a plate or dish. The handle is welded.



Pancake pan, blue steel



Code	Designation	Øcm	Lcm	Hcm	Th.mm	Kg	PU
5303.18		18	36	1,5	2	0,58	10
5303.20		20	38	1,5	2	0,69	10
5303.22		22	41,8	1,5	2	0,8	10
5303.24		24	43,5	1,5	2	0,93	10

Blue steel plate is ideal for making crispy, tasty crepes. The low skirt of the frying pan allows crepes to be easily flipped and turned. The handle is welded.

Box of 10 neoprene handle gloves for thermic protection



Code	Designation	Lcm	Wcm	Hcm	Kg
4636.00		20,5	13	5,5	0,26





#OUTDOOR

Preparing • Cutting • Spicing • Marinating
Grilling • Searing • Cooking
Meat • Fish • Vegetable
Pizza • Baking

When it's finally summer,
we all love to cook outside.

Whether it's on a grill, pizza oven or firepit, people love cooking outside
during the best weather of the year.

When thinking about cooking, de Buyer utensils are essential, even for out-
doors. Discover our product selection

-25 -
Griddle

-26 -
Blue steel frypan

-29 -
Utensils



PIZZA PLANCHA BBQ # OUTDOOR GRIDDLE GRILL

CONCEPT #OUTDOOR : POS & package



Code	Designation	Lcm	Wcm	Hcm
20.500	Totem #OUTDOOR		54,5	159
20.504	Recipes book #OUTDOOR			
POS pack 4 pcs :				
20.501 + 2 x 20.502 + 20.503				
20.501	Cardboard flag for display	60		18
20.502	Shelf cover	40		3,5
20.503	Cardboard chain			

- digital kits

#OUTDOOR CONCEPT

Merchandising dedicated to the #OUTDOOR collection
Seasonal in-store events.

Tools available to you for in-store promotions:
dedicated packaging recipes - background visuals

Contact us for conditions of provision.



In the following pages, this symbol designates products with special OUTDOOR packaging



The blue carbon steel frying pan

The perfect pan to cook like a professional chef and rustle up delicious barbecue or plancha grills. Whether you want a tasty piece of grilled beef, generously sprinkled with freshly-milled pepper, or barbecue flavored summer vegetables, de Buyer has brought out the ideal frying pan.



Electrical griddle Plancha #OUTDOOR 60 X 40 cm

Gas Plancha #OUTDOOR 60 x 40 cm



Code	Designation	Lcm	Wcm	Hcm	Kg
	220 V				
	Norm CE				
	6-10 p.				
4420.00	Griddle without lid	62	49	27	27

St/steel chassis. Enamelled cast iron plate dimension 60x40 cm.
Easy cleaning.
High performance: independent heating power with 2 radiants. 2 cooking areas.
T° from 50 to 300°C.

High durability: stainless steel base - Splashproof with a satin finish.
Hidden draining system: push/pull opening system.
Norm IPX4 (resist to water splash).

Code	Designation	Lcm	Wcm	Hcm	Kg
	Norm CE				
	6-10 p.				
4420.01	Griddle without lid	62	52	27	26,4
4420.02	model for Germany				

Suitable for butane or propane gas. burners with thermocouple protection.
In accordance with European regulation. Integrated piezo at control buttons
Stainless steel and steel chassis. Hidden draining system: push/pull opening system.
Enamelled cast iron plate dim: 60x40 cm - Easy cleaning
High performance: p-shaped stainless steel

Lid for griddle Plancha #OUTDOOR L.60 cm

Cover for griddle Plancha #OUTDOOR L.60 cm without lid



Code	Designation	Lcm	Wcm	Hcm	Kg
4420.50	Stainless steel	61	47	16	5,6
4420.51	Black Epoxy	61	47	16	5,6

Code	Designation	Lcm	Wcm	Hcm	Kg
4420.60		62	52	27	0,5

Sideboard for griddle Plancha #OUTDOOR

Code	Designation	Lcm	Wcm	Hcm	Kg
4420.03		99	64	102	31,5



Top shelf 87x54 cm
2 shelves 43x36 cm
Backsplash with kitchen utensils rack 87x27 cm: useful for hanging spatulas

EASY OPENING «push-pull» door system
EASY TO MOVE : 2 wheels with wheel covers and 1 handle

PIZZA PLANCHA BBQ # OUTDOOR GRIDDLE GRILL

BLUE STEEL - EXTRA-STRONG quality

2 mm thick for professional medium heat sources
 Perfect heat conduction
 Welded extra-strong handles
 For pan with steel handle:
 possible oven cooking 10 minutes / 200°C
 All heat sources (induction at moderate T°)
 Made in France

Perfect for SEARING, FRYING, BROWNING



Frying pan, blue steel



Code	Designation	Øcm	Lcm	Hcm	Th.mm	Kg	PU
5400.20		20	37	4,2	2	0,95	6
5400.24		24	43,5	4,5	2	1,26	6
5400.28		28	50	5	2	1,66	6
5400.32		32	56	5,5	2	2,1	3
5400.36		36	67	6	2	2,57	3
	BLINIS PAN						
5440.12		12	24	2	2	0,33	20

This "lyonnaise" profile pan made from 2mm (14 gauge) blue steel plate gives very good heat spread. It has a high flared and curved skirt. This very distinctive shape, with no sharp angles, enables the food to slide easily from the frying pan onto a plate or dish. The strip steel handle is firmly riveted.



Round "Country" frypan , 2mm blue steel



Code	Designation	Øcm	Lcm	Hcm	Liters.	Th.mm	Kg	PU
5414.20		20	39,5	6	1,7	2	1,19	3
5414.24		24	46,5	6,8	2,5	2	1,58	3
5414.28		28	51,5	7	4	2	1,96	3
5414.32	With 2 handles	32	66,5	8	5,5	2	2,46	3

Between the curved sauté pan and the "Lyonnaise" profile frying pan, this high-sided pan is ideal for all styles of cooking, including frying, searing, grilling. It can be used to prepare large quantities of ingredients and its high sides reduce the amount of juice spat out when cooking meats. Ideal for sauteed potatoes.



Perforated vegetable pan, blue steel



Code	Designation	Øcm	Th.mm	Kg	PU
5490.00	with 1 handle	28	2	1,3	3
5408.28	with 2 handles	28	2	1,3	3

The perforations ensure direct cooking and when cooking on coals give your food the perfect barbecue flavor.

Chestnut pan with side ventilation



Chestnut pans, blue steel



Code	Designation	Øcm	Hcm	Th.mm	Kg	PU
5493.28		28	4,7	1,1	0,91	10

Chestnut pan with side ventilation for improved heat circulation: an exclusive process allows this chestnut pan to be used on all types of hotplates, including gas and induction.

The grooved bottom allows the chestnuts to roast better.

Code	Designation
5490.28	
5491.28	

The chestnut pan with holes in the bottom is a traditional utensil, always made out of steel plate for ruggedness. This design of chestnut pan is exclusively for use on hot coals.

Pancake pan, blue steel



Code	Designation	Øcm	Lcm	Hcm	Th.mm	Kg	PU
5303.18		18	36	1,5	2	0,58	10
5303.20		20	38	1,5	2	0,69	10
5303.22		22	41,8	1,5	2	0,8	10
5303.24		24	43,5	1,5	2	0,93	10

Blue steel plate is ideal for making crispy, tasty crepes. The low skirt of the frying pan allows crepes to be easily flipped

and turned. The handle is welded.





Paella pan, blue steel



Code	Designation	Øcm	Lcm	Hcm	Th.mm	Kg	PU
5023.20		20			1		3
5023.28		28			1		3
	While stocks last						
5023.34	6 portions - 1,5 mm th	34	42	4,5	1,5	1,43	3
5023.37	8 portions - 1,5 mm th	37	44,4	5	1,5	1,61	3
5023.42	12 portions - 1,5 mm th	42	49,5	5,5	1,5	2,05	3
5023.47	15 portions - 1,5 mm th	47	55	6	1,5	2,64	3
5023.60	25 portions - 1,5 mm th	60	68	6,5	1,5	3,91	1

The paella dish is not only typical but also has lots of other possible uses: it goes on the hotplate but also in the oven if size allows, and in certain establishments, it goes on the table too. This dish is of medium height and makes it easy to prepare paella or other dishes.

Chrome steel burner tripod



Code	Designation	Lcm	Wcm	Hcm	Kg
0820.00N		59	55	66,5	2,17

The tripod provides a fixed support for the "paella special" gas burner, giving a stable cooking surface when making paellas out in the open. It adapts to burner size up to ø 60/70 cm and bears about 60 kg.

Gas burner, enamelled steel



Code	Designation	Øcm	Lcm	Hcm	Kg
0816.40N	For paella pan 60-100 cm- 11,7 KW	41	69	11,1	2,51
0816.50N	For paella pan 60-100 cm - 14 KW	50	84,2	12	3,19
0816.60N	For paella pan 60-100 cm- 19,25 KW	60	94,7	13	3,78

In accordance with European regulations
 Gas burner delivered without adapter
 Standard model with a 37-millibar pressure
 Indicate with order the country where the burner will be used to adapt it.

This burner has independent and separately controllable flame rings and allows a dish or other receptacle to be heated wherever needed and without over-bulky or costly equipment. It's the ideal complement to the paella dish for alfresco meals or for use in reception rooms where improvised "kitchens" or "buffets" are laid out. The gas burner is suitable for both butane and propane.

Paella pan "Viva España", 2 red handles, steel



Code	Designation	Øcm	Hcm	Th.mm	Kg	PU
5026.24N	1 portion	24	3,5	1	0,4	6
5026.28N	3 portions	28	3,7	1	0,51	6
5026.32N	5 portions	32	4	1	0,68	6
5026.36N	7 portions	36	4	1	0,97	6
5026.40N	9 portions	40	4,4	1	1,28	6
5026.46N	12 portions	46	5	1	1,9	4
5026.50N	14 portions	50	5	1	2,22	4
5026.60N	19 portions	60	5	1	4,09	4
5026.70N	25 portions	70	5	1	7	1
5026.80N	40 portions	80	5,2	1	9,3	1
5026.90N	50 portions - 4 handles	90	6,2	1,5	12	1

From 1.0 to 1.5mm thick (16 to 20 gauge), this paella dish is modeled on the typical Spanish shape, with a relatively low skirt.

The hammered bottom gives this item a distinctive look.

KOBRA V AXIS : Professional fruit and vegetable slicer with pusher



Code	Designation	Lcm	Wcm	Hcm	Kg
2011.01	Complete with pusher - Black	36,5	12,2	8	0,66
2011.41	Complete with pusher - Red	36,5	12,2	8	0,66
SPARE PARTS :					
2011.55	Pusher alone				

- V-shaped blade: the blade penetrates the product easily.
- Optimised cutting angle at 19,3°. Cuts easily and perfectly all fruits and vegetables, even the softest ones (tomatoes, pears, etc.).
- Micro-serration of the blade enables the thinnest cut of fruit/vegetable with skin and preserves their flesh composition.

- PRACTICAL & EASY: easy to adjust the height of the cut: the thumb wheel integrated at the end of the handle allows the adjustment of the thickness up to 5 mm. - St/steel ramp
- COMPACT: the pusher clips on for easy storage.
- SAFE Protective pusher. Silicone moulded anti-sliding ergonomic handle. Anti-skid feet.



Asian Chef's knife



Code	Designation	Lcm	Wcm	Hcm	Kg
4280.15	L. 15 cm	28,6	4,9	2	0,16
4280.17	L. 17 cm	30	5,5	1,8	0,18

This 15cm Asian Chef's knife is very light and sharp and easy to maneuver for light quick cutting tasks in busy kitchens. It is also designed to be ideal for young cooks or for small hands.

Utility knife L. 14 cm



Code	Designation	Lcm	Wcm	Hcm	Kg
4285.14		26,7	2	3	0,14

Small chopping/slicing knife for many light meat/vegetable jobs for chefs and home cooks.

Flat bottom bowl



Code	Designation	Øcm	Hcm	Liters.	Th.mm	Kg
3250.20		20	10	2	0,8	0,24
3250.24		24	11,2	3,5	1	0,4

Bowls for professional use, as much for their capacity as for the quality and thickness of the stainless steel used. They have an open rolled rim: rolled for handling without injury and open for improved hygiene. Polished finish.

Flat-edge rectangular deep dish, conical



Code	Designation	Lcm	Wcm	Hcm	Liters.	Th.mm	Kg	PU
3283.27		27	22	4	1,9	1	0,63	10
3283.30		30	25	4,3	2,6	1	0,79	10

These stainless steel dishes are particularly resistant to knocks that happen during the course of handling. Besides this, they comply with professional dimensions.



Utility tongs



Code	Designation	Lcm	Th.mm	Kg	PU
4788.40N		40	0,5	0,2	12

Stainless steel tweezer with curved end



Code	Designation	Lcm	Kg
4239.35		35	0,17



Skewers, stainless steel



Code	Designation	Lcm	Th.mm	Kg
3401.25	Set of 10	25	2	0,01
3401.30	Set of 10	30	2	0,01
3401.35	Set of 10	35	2	0,01
3401.40	Set of 10	40	2	0,02

Easily slice through meat and vegetables thanks to the bevelled tips. Made of flat stainless steel wire, food won't slip off during cooking. Robust and reusable.

Silicone brush



Code	Designation	Lcm	Wcm	Kg
4807.25N		25	3	0,04

Hygienic brush. Easily cleanable. T° resistance until 250°C.





Triangular spatula FKOfficium

Code	Designation	Lcm	Wcm	Kg
4233.01	L. blade 8 cm	26,5	8	0,11



With its special shape, this spatula lets you clean grids and hotplates. Its width and sharp angles also allow you to cut or spread pasty substances or to peel chocolates off their baking sheets.

Stainless steel flexible turner FKOfficium

Code	Designation	Lcm	Wcm	Kg
4235.00	L.blade 17 cm	31	7,8	0,1



This food turner is made from forged stainless steel. Its springiness makes food easy to handle and turn.

Cranked spatola FKOfficium inox

Code	Designation	Lcm	Wcm	Kg
4232.00	L. blade 12 cm	30	9	0,14



High resistance thanks to the thick stainless steel of the blade. The bevelled blade allows easy sliding under food. Wide angled design ensures you can easily turn any piece of meat or kind of burger.

Dredger, stainless steel

Code	Designation	Øcm	Hcm	Liters.	Kg
4783.03N	Spices dredger - large holes 2,5 mm	7	10	0,31	0,14





Stainless steel round ring ø 8 cm



Code	Designation	Øcm	Hcm	Th.mm	Kg	PU
3989.08		8	4,5	0,8	0,08	6

Enables you to cook your flans ans gratins directly and quickly on a grill.

Pizza cutting wheel



Code	Designation	Øcm	Th.mm	Kg
4970.10N	Pizza cutting wheel	10	1	0,17

This particularly sturdy pizza cutter has an ergonomic handle for a firm grip. Its stainless steel beveled blade allows pizza to be easily cut into portions.

Round pizza tray, heavy blue steel



Code	Designation	Øcm	Th.mm	Kg	PU
5350.28		28	1	0,52	5

The plaque will not distort and ensures good heat transmission. This steel plate has a high-quality surface that will not stain pastry bottoms; it is micro-roughened, creating an air mattress between the food to be cooked and the metal. Ideal for pizzas.



Spices lacquered mill RUMBA 20 cm, ceramic mechanism



Code	Designation	Hcm	Kg
C030.203232	Red	20	0,35
C030.203333	Black	20	0,35

Ceramic mechanism suitable for various spices. This range of classical mills is made of beech wood. The wood is lacquered : one coat of white lacquer then three coats of the color. The glossy lacquered finish and the vitamin shades bring a colourful touch and brighten up the kitchen and table.

Preparation dish with 6 cells, stainless steel

Code	Designation	Lcm	Wcm	Hcm	Th.mm	Kg
3221.06		40	30	1,6	0,8	0,7



Ideal dish for preparing different dishes and separating them. Robust, resistant and undeformable stainless steel. 6 cells. Rounded corners for easy maintenance. Gloss polished finish. Hygienic and durable.

Mug with 2 folding handles, stainless steel



Code	Designation	Lcm	Wcm	Hcm	Liters.	Th.mm	Kg	PU
3979.00		13,6	9	9,5	0,7	0,7	0,21	10

The mug is a piece of camp equipment meant for a soldier's use. This stainless steel model is especially robust and hygienic and is easy to keep clean. The two handles fold away to take up less room.

Plastic water bottle (Army model), fitting into the mug



Code	Designation	Lcm	Wcm	Hcm	Liters.	Kg	PU
4959.00	Green NATO	13,2	8,1	22,8	1,3	0,14	20

2-level smoker oven for hot and cold smoking - Stainless steel



Food is subjected, over a prolonged period, to smoke which has an antiseptic effect and increases shelf life, at the same time enhancing the taste. Smoking gives food a woody taste. More specifically, you can smoke meat (steak, chops, filet mignon, etc.), poultry (chicken, duck, etc.), charcuterie (essentially ham, bacon, large sausages, small sausages, andouilles [spicy sausages]) and fish (salmon, trout, eel, mackerel, etc.). The principle lies in exposing food to smoke at different temperatures, depending on the desired result.

Sawdust is sterilized and dust free. Guaranteed without chemical. Sawdust HB50/1000. Grain size : 0.5 to 1.0mm. Humidity 8 to 12 %. In compliance with the standards DIN ISO 9001.

Code	Designation	Lcm	Wcm	Hcm	Kg
3441.60	large 60 x 40 cm	60	40		
3441.00	small 31 x 31 cm	31	31	20	7,3
	Composition :				
	Smoking chamber with lid				
3441.93	st/steel grid for smoker 31x31 cm				
3441.91	Oven and lid				
3441.90	Fire pit				
3441.92	Aluminium telescopic and flexible pipe				
	One thermometer				
	500 g. of sawdust				
	2 removable feet				
	Delivered with smoking advice and recipes				
	To be assembled				
	Beech sawdust for food smoking:				
4441.01	Bag of 0,5 kg				0,51
4441.15	Bag of 15 kg				15,1





OUTSTANDING NON-STICK PANS

Our non-stick ranges are recommended for low-temperature cooking as they cook up dishes with great care without altering food. These pans are thick and have non-hazardous coatings allowing you to cook without using fat nor oil.

De Buyer will even recycle them.

- 37 -

Cast aluminium INDUCTION
CHOC EXTREME

- 40 -

Forged aluminium INDUCTION
CHOC BBOIS & CHOC INTENSE

- 44 -

Aluminium CHOC RESTO INDUCTION

- 47 -

Aluminium CHOC

- 51 -

Aluminium CHOC ACCESS



NON-STICK RANGE

	FORGED ALUMINIUM			ALUMINIUM		
Collection	CAST D'ALUMINIUM CHOC EXTRÊME	CHOC BOIS	CHOC INTENSE	CHOC RESTO	CHOC CLASSIC	CHOC ACCESS
Thickness	7 mm	4 mm	4 mm	4 to 5 mm	3,3 to 5 mm	3 to 4 mm
Cooking methods	Reheating / Frying / Simmering					
Designed for cooking						
PFOA and PFOS free non-stick coating resistance	EXTRA LONG LASTING RESISTANCE	LONG LASTING RESISTANCE	ULTRA RESISTANT	VERY RESISTANT	RESISTANT	
Heat sources						
Base of the utensil	Welded and brazed induction disc	Forged aluminium induction disc		Forged honeycomb induction disc	Pressed aluminium	
French-style curved handle	Cast stainless steel handle	Steel strip and wood handle	Stainless steel strip handle	bakelite removable handle	Steel strip handle	
Fixing of the handle or base	Riveted + heat-stop	Riveted				
Use in the oven	Max 250°C (except grill)	Flash heat : 10 min at 200°C	Max 250°C (except grill)	Flash heat : 10 min at 200°C		
Dishwasher cleaning	Occasional to avoid affecting the non-stick properties					
Diameter (cm)	18 to 36	20 to 36	20 to 36	20 to 32	12 to 40	20 to 40
PCB (packaging unit)	1	1	1	3	3	3

CHOC EXTREME

Cookware made of real pressure cast aluminium
 Improved higher quality non-stick coating
 ULTRA REINFORCED - Guaranteed without PFOA or PFOS
 EXTREME HARD = longer lifetime
 Undistortable thick magnetic bottom
 All heat sources including induction

For simmering, reheating and cooking delicate dishes

CHOC EXTREME



Round non-stick frypan CHOC EXTREME with riveted cast st/steel handle

Code	Designation	Øcm	Lcm	Hcm	Th.mm	Bottom ø cm	Kg
8300.20		20	40	4,5	3	14	0,8
8300.24		24	46,5	4,5	3	16	1,16
8300.28		28	54	4,5	3	18,5	1,45
8300.32	with 2 handles	32	63	4,5	3	22	2,27



CHOC EXTREME is made from pressure cast aluminium and is covered with the highest quality non-stick coating which is consolidated by a PTFE projection. It stands up excellently to deformation, knocks, and sudden changes in temperature. This frying pan is ideal for providing regular cooking conditions as its very thick base cuts out sudden, unwelcome reactions when too much heat is applied. The ergonomic cast st/steel handle is firmly riveted.

Round nonstick frypan CHOC EXTREME with tubular stainless steel handle

Code	Designation	Øcm	Hcm	Th.mm	Bottom ø cm	Kg
8310.20		20	4,2	3	12,5	0,8
8310.24		24	4,2	3	16	1,2
8310.28		28	4,6	3	18,5	1,8
8310.32		32	4,6	3	22	2
8310.36	with 2 handles	36	4,6	3	23	2,5

CHOC EXTREME is made from pressure cast aluminium and is covered with the highest quality non-stick coating which is consolidated by a PTFE projection. It stands up excellently to deformation, knocks, and sudden changes in temperature. This

frying pan is ideal for providing regular cooking conditions as its very thick base cuts out sudden, unwelcome reactions when too much heat is applied. The ergonomic st/steel handle is firmly riveted.

Round non-stick saucepan CHOC EXTREME with riveted cast stainless steel handle

Code	Designation	Øcm	Hcm	Th.mm	Bottom ø cm	Kg
8309.00		18	9	1	12	1
	While stocks last					

Non-stick sauté-pan with riveted cast st/steel handle

Code	Designation	Øcm	Lcm	Hcm	Liters.	Th.mm	Bottom ø cm	Kg
8304.20		20		6,2	1,5	3	12	0,95
8304.24		24	47,2	6	2,5	3	16	1,45
8304.28		28	53,5	6	3,5	3	19,5	1,71

Non-stick coating on a hard stainless backing, abrasion and scrape resistant. This sauté pan is ideal for simmering food. Ergonomic functional cast stainless steel handle firmly riveted. All hotplates including INDUCTION

Glass lid with stainless steel knob

Code	Designation	Øcm	Kg
3429.16		16	0,29
3429.20		20	0,41
3429.24		24	0,58
3429.28		28	0,74
3429.32		32	1,1
3429.36		36	1,2

These glass lids with stainless steel button fit the CHOC EXTREME range of pans and sauté pans. Suitable for oven cooking.

Mould for upside down pie "Tatin", non-stick cast aluminium CHOC EXTREME Induction

Code	Designation	Øcm	Hcm	Bottom ø cm	Kg
8320.24	4/6 p.	24	5	16	0,82
8320.28	6/8 p.	28	5,5	18,5	1,2

This mould proves ideal for Tatin tarts, since it allows you to form a caramel layer directly in the mould while it's on the heat. Once the caramel is formed in the mould, just add the apple slices, cover with pastry, and place the mould in the oven. Pressure cast aluminium is ideal for providing regular cooking conditions and excellently to deformation.



Stewpan, 2 handles, with glass lid - CHOC EXTREME



Code	Designation	Øcm	Lcm	Hcm	Liters.	Th.mm	Bottom ø cm	Kg
8311.20		20	27	8,5	2,8	3	14,5	1,37
8311.24		24	33,5	9,5	4,7	4	16,5	1,76
8311.28		28	37	10	7	4	18,5	2,45

Suits with its lid for oven cooking.

Wok CHOC EXTREME, with 2 handles



Code	Designation	Øcm	Lcm	Hcm	Th.mm	Bottom ø cm	Kg
8317.00	Wok	32		11	3	18	1,62
3329.10	Grid for wok ø 32 cm		34,5				0,14

The glass lid 3429.32 suits on the wok.

Sauté-pan, 2 handles, without glass lid - CHOC EXTREME



Code	Designation	Øcm	Lcm	Hcm	Th.mm	Bottom ø cm	Kg
8313.20	Sauté-pan without lid ø 20 cm	20	27	6	3	12,5	0,96
8313.24	Sauté-pan without lid ø 24 cm	24	31	6	4	15,5	1,28
8313.28	Sauté-pan without lid ø 28 cm	28	35	6,5	4	19,5	1,74
8313.32	Sauté-pan without lid ø 32 cm	32	40,5	7,5	4	22	2,16
8313.36	Sauté-pan without lid ø 36 cm	36		8,5	4	23	2,75

The two-handed sauté dish allows quick browning of food. It has the same uses as a one-handed sauté pan but turns out to be more practical to handle and takes up less space when stored away or when on the burner.

Box of 10 neoprene pairs of handle gloves for thermic protection



Code	Designation	Lcm	Wcm	Hcm	Kg
4636.10	Small size 7 cm	24	14,5	6	0,36
4636.20	Large size 11 cm for for ø36 cm	24	14,5	6	0,44

Fits to the handles of stewpan, sauté-pan etc. to handle without any risk of burning

NONSTICK PAN CHOC B BOIS - FORGED ALUMINIUM

The forging process, undertaken during manufacturing, makes the aluminum harder and more durable.

Riveted handle made of steel and beechwood.

The beech wood used is a wood coming from sustainably managed forests.

The high-end PTFE coating preserves its non-stick properties for longer (50% longer lifetime) allowing to cook healthier dishes using less fat.

PFOS and PFOA free.

Suitable for all hotplates including INDUCTION - Possible oven cooking 10 minutes / 200°C

Made in France

'B Bois' products are exclusively sold via physical retailers.



Round nonstick frypan Choc B BOIS

Code	Designation	Øcm	Lcm	Hcm	Th.mm	ø bottom cm	Kg
8780.20		20	36,7	3,2	4	14	0,81
8780.24		24	44	3,7	4	16,6	1,06
8780.28		28	50	4	4	18	1,34
8780.32		32	57	4,5	4	20	1,73



Strip steel handle with beech wood treated with beeswax for the nonstick pan CHOC B BOIS. Nonstick coating on the whole pan, on inner and outer sides.

Optimum resistance to abrasion + better non-stick and slip qualities.

Suitable for all heat sources including induction. Possible oven cooking 10 minutes / 200°C.

Nonstick pans are ideal for simmering, reheating cooking and cooking delicate dishes.

Rounded sauté-pan CHOC B BOIS



Code	Designation	Øcm	Th.mm	ø bottom cm	Kg
8788.24		24	4	16,6	1,28
8788.28		28	4	22	1,55

Glass lid with beechwood knob



Code	Designation	Øcm	Hcm	Kg
4111.20		20	7,5	0,4
4111.24		24	7,5	0,53
4111.28		28	7,5	0,7
4111.32		32	7,5	1

Fits on all the pans of the CHOC B BOIS range.

Round crepe pan CHOC B BOIS



Code	Designation	Øcm	Th.mm	ø bottom cm	Kg
8785.26		26	4	18	0,87
8785.30		30	4	22	1,19

**NONSTICK PAN CHOC INTENSE
FORGED ALUMINIUM**

Riveted stainless steel handle - Gloss finish.

The forging process, undertaken during manufacturing, makes the aluminum harder and more durable

A next generation ultra-thick reinforced non-stick coating guarantees unparalleled effectiveness and high resistance to abrasion

The high-end PTFE coating preserves its non-stick properties for longer time (50% longer lifetime) allowing to cook healthier dishes using less fat.

PFOS and PFOA free.

Suitable for all hotplates including INDUCTION - Possible oven cooking. Easy to clean.

Made in France

**CHOC
INTENSE**



Round nonstick frypan CHOC INTENSE, stainless steel handle



Code	Designation	Øcm	Th.mm	ø bottom cm	Kg
8760.20		20	4	14	0,65
8760.24		24	4	16,6	0,9
8760.28		28	4	20,6	1,19
8760.32		32	4	22	1,44

Glass lid with stainless steel knob



Code	Designation	Øcm	Kg
3429.20		20	0,41
3429.24		24	0,58
3429.28		28	0,74
3429.32		32	1,1

These glass lids with stainless steel button fit the CHOC INTENSE range of pans. Suitable for oven cooking.



Rounded sauté-pan CHOC INTENSE



Code	Designation	Øcm	Th.mm	ø bottom cm	Kg
8768.24		24	4	16,6	1,18
8768.28		28	4	22	1,45

Round crepe pan CHOC INTENSE



Code	Designation	Øcm	Th.mm	ø bottom cm	Kg
8765.26		26	4	18	0,84
8765.30		30	4	22	1,11

CHOC INTENSE nonstick pan with removable handle is also available
See page 76



DISPLAY PODIUM CHOC Retail ref 10.8300

for the promotion of the nonstick ranges
CHOC EXTREME / CHOC B BOIS / CHOC INTENSE
Dimensions 30,5 x 29,5 x ht 47 cm
Suitable for ø 24 cm

PROFESSIONAL PANS
 MADE OF NON-STICK ULTRA THICK ALUMINIUM
 FORGED INDUCTION BOTTOM
 HONEYCOMBED & EMBEDDED
 = perfect heat distribution and optimal fit

Improved PTFE 5-LAYER coating - no PFOA, no PFOS
 for a better resistance to abrasion and to heat
 Optimum non-stick and slip qualities
 Riveted steel handle: possible oven cooking 10 minutes / 200°C

For simmering, reheating and cooking delicate dishes



Round nonstick frypan CHOC Resto Induction made of thick aluminium

Code	Designation	Øcm	Lcm	Hcm	Th.mm	Bottom ø cm	Kg
8480.20		20	36,7	3	5	12	0,78
8480.24		24	43,5	3,5	5	14	1,03
8480.28		28	50	3,8	5	18	1,31
8480.32		32	55,6	4,5	5	20	1,7
8480.36		36	66	4,7	5	24	2,45



The professional non-stick aluminium frypan CHOC RESTO INDUCTION is covered with a high-quality improved PTFE coating . Therefore, it is resistant to abrasion and to heat. The strip handle is firmly riveted and covered with a heat-resistant epoxy. All hotplates.

Non-stick aluminium frypan CHOC Resto Induction with red handle - HACCP



Code	Designation	Øcm	Lcm	Hcm	Th.mm	ø bottom cm	Kg
Red handle for red meat							
8450.20		20	36,7	3	5	12	0,78
8450.24		24	43,5	3,5	5	14	1,03
8450.28		28	50	3,8	5	18	1,31
8450.32		32	55,6	4,5	5	20	1,7

The traditional non-stick frypan CHOC made of thick aluminium is equipped with a heat resistant coloured cast strip handle. Practical and hygienic, this new system avoids cross contamination (transfer of bacteria from one food to another). You simply cook different foods in different frypans. It is helpful in professional kitchens that must observe strong hygiene regulations.

Non-stick aluminium frypan Choc Recto Induction with green handle -HACCP



Code	Designation	Øcm	Lcm	Hcm	Th.mm	ø bottom cm	Kg
Green handle for vegetables							
8460.20		20	36,7	3	5	12	0,78
8460.24		24	43,5	3,5	5	14	1,03
8460.28		28	50	3,8	5	18	1,31
8460.32		32	55,6	4,5	5	20	1,7

The traditional non-stick frypan CHOC made of thick aluminium is equipped with a heat resistant coloured cast strip handle. Practical and hygienic, this new system avoids cross contamination (transfer of bacteria from one food to another). You simply cook different foods in different frypans. It is helpful in professional kitchens that must observe strong hygiene regulations.

Non-stick aluminium frypan CHOC Resto Induction with yellow handle -HACCP



Code	Designation	Øcm	Lcm	Hcm	Th.mm	ø bottom cm	Kg
Yellow handle for white meat							
8470.20		20	36,7	3	5	12	0,78
8470.24		24	43,5	3,5	5	14	1,03
8470.28		28	50	3,8	5	18	1,31
8470.32		32	55,6	4,7	5	20	1,7

The traditional non-stick frypan CHOC made of thick aluminium is equipped with a heat resistant coloured cast strip handle. Practical and hygienic, this new system avoids cross contamination (transfer of bacteria from one food to another). You simply cook different foods in different frypans. It is helpful in professional kitchens that must observe strong hygiene regulations.

Non-stick aluminium frypan CHOC Resto Induction with blue handle -HACCP



Code	Designation	Øcm	Lcm	Hcm	Th.mm	øbottom cm	Kg
Blue handle for fish							
8440.20		20	36,7	3	5	12	0,78
8440.24		24	43,5	3,5	5	14	1,03
8440.28		28	50	3,8	5	18	1,31
8440.32		32	55,6	4,5	5	20	1,7

The traditional non-stick frypan CHOC made of thick aluminium is equipped with a heat resistant coloured cast strip handle. Practical and hygienic, this new system avoids cross contamination (transfer of bacteria from one food to another). You simply cook different foods in different frypans. It is helpful in professional kitchens that must observe strong hygiene regulations.

Pancake non-stick pan CHOC Resto Induction



Code	Designation	Øcm	Th.mm	Bottom ø cm	Kg
8485.26		26	4	18	0,8
8485.30		30	4	22	1



Fish oval non-stick frypan CHOC Resto Induction



Code	Designation	Lcm	Wcm	Hcm	Th.mm	Bottom ø cm	Kg
8481.36		36	26	4,3	5	18	1,7

This non-stick frying pan is ideal for cooking delicate dishes such as fish. The oval shape of this frying pan enables whole fish to be cooked. Firmly riveted steel handle.

Fish oval non-stick frypan CHOC Resto Induction



Code	Designation	Lcm	Wcm	Hcm	Th.mm	Bottom ø cm	Kg
8481.01	Frypan without lid	36	26	4,3	5	18	1,75
8481.00	Frypan with lid	36	26	4,3	5	18	2,6

This non-stick frying pan is ideal for cooking delicate dishes such as fish. The oval shape of this frying pan enables whole fish to be cooked. Firmly riveted steel handle.



**PROFESSIONAL PANS MADE OF THICK ALUMINIUM
NON STICK : high-quality 5-layer PTFE coating**

guaranteed without PFOA Improved resistance to abrasion
Grooved bottom for better heat spreading and cooking
Firmly riveted strip steel handle
All heat sources except induction.
Oven cooking : 200°C during 10 minutes

For simmering, reheating and cooking delicate dishes

Choc



Round frypan CHOC



Code	Designation	Øcm	Lcm	Hcm	Th.mm	Kg	PU
8180.20		20	36,7	3	4	0,61	3
8180.24		24	43,5	3,5	4	0,83	3
8180.26		26	48	3,7	4	0,95	3
8180.28		28	50	3,8	4	1,03	3
8180.30		30	54	4,5	4	1,21	3
8180.32		32	55,6	4,5	4	1,31	3
8180.36		36	66	4,7	5	2,03	3
8180.40		40	70	5,3	5	2,36	3

The non-stick frying pan is ideal for re-warming, for readying pre-cooked dishes for serving, and for cooking delicate dishes. This "lyonnaise" profile frying pan has a high flared and curved skirt. This very distinctive shape, with no sharp angles, enables the food to slide easily from the frying pan onto a plate or dish. The strip steel handle is firmly riveted.

Fish frypans CHOC



Code	Designation	Lcm	Wcm	Hcm	Th.mm	Kg	PU
8181.36	Oval fish frypan	36	26	4,3	5	1,61	3
8181.40	Oval fish frypan	40	28	4,5	5	1,95	3
8184.38	Rectangular frypan	38	26	4,2	5	1,87	3

Oval and oblong frying pans are the ideal shape for cooking whole fish. The non-stick frying pan is ideal for cooking delicate dishes, such as fish. The strip steel handle is firmly riveted.

Paella pan CHOC



Code	Designation	Øcm	Lcm	Hcm	Th.mm	Kg
8183.36	2 handles	36	47	4,7	5	1,84
8183.40	2 handles	40	51	5,2	5	2,16

This paella dish has many possible uses: it goes on the hotplate but also in the oven if size allows, and in certain establishments on the table too. This dish has a relatively high skirt and makes it easy to prepare paella or other dishes.

Blinis pan CHOC



Code	Designation	Øcm	Lcm	Hcm	Th.mm	Kg	PU
8140.12		12	24,2	1,5	3,3	0,2	10
8140.14		14	26	1,7	4	0,24	10

These frying pans allow you to make the well known Russian specialty, blinis as well as fritters and pancakes. The strip steel handle is riveted.

Pancake pan CHOC



Code	Designation	Øcm	Lcm	Hcm	Th.mm	Kg	PU
8185.22		22	42	1,5	3,3	0,6	10
8185.26		26	45	1,5	3,3	0,7	10
8185.30		30	54	1,5	3,3	0,8	5

The non-stick crepe pan has a low skirt and optimum slip qualities, allowing crepes to be easily turned and to slide onto a plate without any problem. Firmly riveted strip steel handle.

Non-stick conical sauté-pan CHOC



Code	Designation	Øcm	Lcm	Hcm	Th.mm	Kg
8188.20		20	35,8	6,5	4	0,9
8188.24		24	43	6,5	4	1,2
8188.28		28	49,5	7,1	4	1,27
8188.32		32	55,6	7,8	5	1,97

The curved sauté pan is ideal for boiling down foods as its small base enables rapid heating and its large rim diameter allows a high degree of evaporation while stirring the contents. Pouring rim and rounded angles.

Non-stick wok CHOC with handle - ø 32 cm



Code	Designation	Øcm	Lcm	Hcm	Liters.	Th.mm	Kg
8187.32		32	62,5	9	3,5	4	1,3

It is the necessary utensil for an healthy and fast cooking. Its form will ensure a good heat allocation but overall it will ensure the food's original qualities conservation .

Roasting pan, 2 handles - Thick aluminium



Code	Designation	Lcm	Wcm	Hcm	Th.mm	Kg
7664.30	Total length : 36 cm	30	30	6,5	4	1,9
7664.35	Total length : 41 cm	35	25	6,5	4	1,81
7664.40	Total length : 46 cm	40	32	8	4	2,6
7664.50	Total length : 56 cm	50	40	8	4	6,61

Useful for cooking, browning meat or serving.

NON STICK PROFESSIONAL CHOC FRYPAN
THICK GAUGE ALUMINIUM
Multi-coated PTFE covering

Riveted extra-strong handle with coloured epoxy coating :

- Food safety
- Keeps each food taste separate

Riveted steel handle: possible oven cooking 10 minutes / 200°C



Round non-stick aluminium frypan CHOC with red handle



Code	Designation	Øcm	Hcm	Th.mm	Kg	PU
Red handle for red meat						
8050.20		20	3	4	0,6	3
8050.24		24	3,5	4	0,9	3
8050.28		28	4	4	1,1	3
8050.32		32	4,5	4	1,6	3

The traditional non-stick frypan CHOC made of thick aluminium is equipped with a heat resistant coloured cast strip handle. Practical and hygienic, this new system avoids cross contamination (transfer of bacteria from one food to another). You simply cook

different foods in different frypans. It is helpful in professional kitchens that must observe strong hygiene regulations.

Round non-stick aluminium frypan CHOC with yellow handle



Code	Designation	Øcm	Hcm	Th.mm	Kg	PU
Yellow handle for white meat						
8070.20		20	3	4	0,6	3
8070.24		24	3,5	4	0,9	3
8070.28		28	4	4	1,1	3
8070.32		32	4,5	4	1,6	3

The traditional non-stick frypan CHOC made of thick aluminium is equipped with a heat resistant coloured cast strip handle. Practical and hygienic, this new system avoids cross contamination (transfer of bacteria from one food to another). You simply cook

different foods in different frypans. It is helpful in professional kitchens that must observe strong hygiene regulations.

Round non-stick aluminium frypan CHOC with blue handle



Code	Designation	Øcm	Hcm	Th.mm	Kg	PU
Blue handle for fish						
8040.20		20	3	4	0,6	3
8040.24		24	3,5	4	0,9	3
8040.28		28	4	4	1,1	3
8040.32		32	4,5	4	1,6	3

The traditional non-stick frypan CHOC made of thick aluminium is equipped with a heat resistant coloured cast strip handle. Practical and hygienic, this new system avoids cross contamination (transfer of bacteria from one food to another). You simply cook

different foods in different frypans. It is helpful in professional kitchens that must observe strong hygiene regulations.

Round non-stick aluminium frypan CHOC with green handle



Code	Designation	Øcm	Hcm	Th.mm	Kg	PU
Green handle for vegetables						
8060.20		20	3	4	0,6	3
8060.24		24	3,5	4	0,9	3
8060.28		28	4	4	1,1	3
8060.32		32	4,5	4	1,6	3

The traditional non-stick frypan CHOC made of thick aluminium is equipped with a heat resistant coloured cast strip handle. Practical and hygienic, this new system avoids cross contamination (transfer of bacteria from one food to another). You simply cook

different foods in different frypans. It is helpful in professional kitchens that must observe strong hygiene regulations.



**ALUMINIUM NON-STICK FRYPAN
SEMI-PROFESSIONAL**

High quality PTFE non-stick coating
All heat sources except induction

Riveted steel handle:
possible oven cooking 10 minutes / 200°C



Round frypan CHOC Access



Code	Designation	Øcm	Lcm	Hcm	Th.mm	Kg	PU
8030.20		20	37	3	3	0,47	3
8030.24		24	43,3	3,5	3,3	0,73	3
8030.28		28	49,5	4	3,3	0,93	3
8030.32		32	55,5	4,5	3,3	1,17	3
8030.36		36	65	4,5	4	1,66	3
8030.40		40	70	5,2	4	2,05	3

The non-stick CHOC Access frying pan enables rapid heating; it has a quality CHOC PTFE coating, thus ensuring optimum non-stick and slip qualities. It benefits from all the advantages of the "lyonnaise" profile. Its handle is firmly riveted.

Spatula for non-stick frypans



Code	Designation	Lcm	Wcm	Kg	PU
4813.01N		28	6,5	0,03	5

This flexible nylon spatula has rounded edges and is recommended for use with CHOC cooking utensils as it avoids damaging their non-stick coating. Heat resistant.

Box of 10 neoprene handle gloves for thermic protection



Code	Designation	Lcm	Wcm	Hcm	Kg
4636.00		20,5	13	5,5	0,26



STAINLESS STEEL: A CLASSIC

Our stainless-steel products are must-have utensils for any kitchen. Its safe and durable stainless steel makes it easy to maintain. It's "pure gold". The AFFINITY multi-layer range is worth a special mention: the products heat up quickly and distribute heat beautifully.

st/steel
cookware

- 56 -

Multilayer stainless steel material 5 layers
AFFINITY

- 61 -

Multilayer stainless steel material 3 layers
ALCHIMY

- 65 -











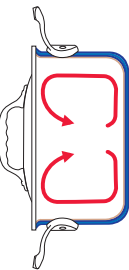
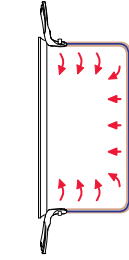
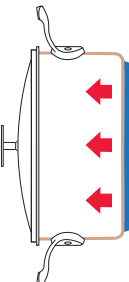
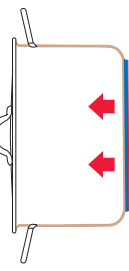







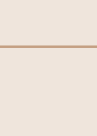

Stainless steel with sandwich bottom
MILADY

- 67 -

Stainless steel with sandwich bottom
PRIM'APPETY





MULTI-LAYERS		SANDWICH BASES		
5-ply	3-ply	MILADY	TWISTY	PRIM'APPETTY
AFFINITY	ALCHEMY			
Collection				
Thickness	2,3 to 2,7 mm	2,3 to 2,7 mm	0,6 to 0,8 mm	0,8 to 1 mm
Cooking methods	Browning / Blanching / Frying			
Designed for cooking				
Finish	Shiny polish	Brushed polish	Shiny polish	Brushed polish
Heat sources				
Base of the utensil	Multi-layer	Multi-layer	Thick sandwich base (7 mm)	Sandwich base diffuser (4 to 7 mm)
French-style curved handle	Cast stainless steel handle	Sealed stainless steel tubing handle	Cast stainless steel handle	Stainless steel tubing handle
Fixing of the handle or base			Riveted	Spot welded
Heat stop				
Use in the oven				
Dishwasher cleaning				
Pouring edge	✓	✓	✓	✓
Diameter (cm)	9 to 32	14 to 32	14 to 28	12 to 50
PCB (packaging unit)	1	1	1	1

COOKWARE AFFINITY

Innovative heat conductor multilayer stainless steel alloy - 5 layers:

- HOMOGENEOUS COOKING
- PERFECT HEAT DISTRIBUTION IN THE PAN
- SAVING VITAMINES AND ENERGY QUICK HEAT INCREASE

Gloss finish

Riveted handles made of cast stainless steel.

One-piece construction - Do not distort.

Thickness from 2,3 to 2,7 mm

Suitable for all heat sources and oven cooking.

Made in France

AFFINITY



Davy Tissot
winner of the Bocuse
d'Or France 2019,
French candidate for
the Bocuse d'Or 2021



Saucepan Affinity



Code	Designation	Øcm	Hcm	Liters.	Th.mm	Bottom ø cm	Kg
WITHOUT LID							
3706.14		14	7	1,2	2,3	12	0,73
3706.16		16	8	1,8	2,3	13	0,95
3706.18		18	9	2,5	2,3	15,6	1,12
3706.20		20	10	3,4	2,3	17	1,38
3706.24		24	13	5,8	2,3	20,5	2,4
3706.01	Set of 3 saucepans ø16/18/20 cm				2,3		3,5
WITH LID							
3746.16		16	8	1,8	2,3	13	0,91
3746.18		18	9	2,5	2,3	15,6	1,32
3746.20		20	10	3,4	2,3	17	1,38

Innovative heat conductor multilayer stainless steel alloy :

- QUICK HEAT INCREASE
- SAVING VITAMINES AND ENERGY
- PERFECT HEAT DISTRIBUTION IN THE PAN
- HOMOGENEOUS COOKING

Suitable for all heat sources and oven cooking.

- One-piece construction - Do not distort.
- Riveted handles made of cast stainless steel.

Straight sauté-pan Affinity



Code	Designation	Øcm	Hcm	Liters.	Th.mm	Bottom ø cm	Kg
3730.16		16	6	1	2,3		0,85
3730.20		20	6,5	1,7	2,3	17	1,16
3730.24		24	7	3	2,7	20,5	1,54
3730.28		28	7,5	4,6	2,7		2

This straight-rimmed sauté-pan is perfect for quickly browning food. Its shape assures that the humidity produced will evaporate quickly and that the juices will caramelize thoroughly.



Rounded sauté-pan Affinity



Code	Designation	Øcm	Hcm	Liters.	Th.mm	Bottom ø cm	Kg
3736.20		20	6,5	1,7	2,3	13	0,92
3736.24		24	7	3	2,3	17	1,34

This is the essential tool for boiling and reducing sauces. A base that is small in diameter for prompt heating and a wide rim for proper evaporation of the humidity produced. Thanks to this vessel, you will be able to prepare unsurpassable sauces.

Non-stick frypan Affinity



Stainless steel frypan Affinity



Code	Designation	Øcm	Lcm	Hcm	Th.mm	Bottom ø cm	Kg
3718.20		20	35,3	3	2,7	14	0,71
3718.24		24	42	3,5	2,7	17	1,1
3718.28		28	48	4	2,7	20	1,35
3718.32		32	55,4	4,5	2,7	23	1,72

This non-stick frying pan is ideal and allows delicate dishes like fish to be prepared with perfection. It is covered with PTFE and has a solid bottom that resists abrasion.

Code	Designation	Øcm	Hcm	Th.mm	Bottom ø cm	Kg
3724.20		20	4	2,7	14	0,69
3724.24		24	4	2,7	17	1,1
3724.28		28	4,5	2,7	20	1,34
3724.32		32	5	2,7	23	1,71

This totally stainless steel Affinity frying pan is ideal for quickly frying and grilling meat, thanks to its ability to rapidly increase in temperature. The quality of stainless steel

used to construct this frying pan qualifies it as a strong ally in the quest to caramelize your meat.

Wok Affinity with 2 cast st/steel riveted handles



Code	Designation	Øcm	Lcm	Hcm	Liters.	Th.mm	Bottom ø cm	Kg
3743.32	ø bottom 10 cm	32		12	4	2,7	9,5	1,9
3329.10	Grid for wok ø 32 cm		34,5					0,14
	Glass lid suitable for wok Affinity :							
	Glass lid with stainless steel handle							
3429.32		32						1,1
	Glass lid with bakelite handle							
4112.32		32	7,5					1,1

For all hotplates including induction hobs



Mini sauté-pan Affinity



Code	Designation	Øcm	Lcm	Hcm	Th.mm	Bottom ø cm	Kg
While stocks last							
3740.10		10	17	3,8	2,2	8	0,29

The material from which these mini-stewpan are made allows them to be used on all heat sources. Adapted to today's standards, these mini-stewpans will contribute to the modern and elegant presentation of your dishes. Being made of all stainless steel, they are extremely easy to maintain and are guaranteed to last for

Sauté-pan with lid Affinity



Rounded sauté pan Affinity with st/steel handles and lid



Code	Designation	Øcm	Hcm	Liters.	Th.mm	Bottom ø cm	Kg
3741.20		20	6,3	1,7	2,3		1,15
3741.24		24	7	3	2,7	20,5	1,98
3741.28		28	7,5	4,6	2,7		2

This vessel has the same qualities as the straight-rimmed sauté-pan, but its two handles make it even easier to use and equally less cumbersome. It will easily find its place in your kitchen.

Code	Designation	Øcm	Hcm	Liters.	Bottom ø cm	Kg
3745.28		28	10	4,9	20,5	2,45

Stewpan with lid Affinity



Code	Designation	Øcm	Hcm	Liters.	Th.mm	Bottom ø cm	Kg
3742.16		16	9	1,8	2,3	13	1,01
3742.20		20	11	3,4	2,3	17	1,7
3742.24		24	13	5,4	2,3	20,5	2,33
3742.28		28	15	10,4	2,7	24	3,64

Contrary to other kitchenware, this stewpan conserves humidity thanks to its high sides. Therefore, it is suitable for heating large quantities of water, simmering, etc. The Affinity material guarantees a rapid increase in temperature and therefore saves you a significant amount of time.

Stainless steel steamcooker



Code	Designation	Øcm	Kg
3675.24		24	0,66

Steaming is a quick operation with this stainless steel steamer. Fits to the pan of the stainless steel and copper cookware. Equipped with an handle to remove it easily. Tip from the chef: to make your vegetables glisten, plunge them into cold water once they are cooked.



Oval stewpan Affinity with lid



Code	Designation	Lcm	Wcm	Hcm	Liters.	Th.mm	Kg
3726.30		30	22	13	6,5	2,3	3,6

Oval stainless steel fish frypan Affinity, L. 32 cm



Code	Designation	Lcm	Wcm	Hcm	Th.mm	Bottom ø cm	Kg
3719.32	Nonstick st/steel	32	23	4,8	2,7	23	1,36

Stainless steel lid



Code	Designation	Øcm	Th.mm	Kg
3709.14N		14	1	0,24
3709.16N		16	1	0,28
3709.18N		18	1	0,33
3709.20N		20	1	0,39
3709.24N		24	1	0,51
3709.28		28	1	0,65

This Affinity lid is made to fit all kitchenware in this range, except round frypans.

Roasting-pan Affinity with 2 riveted cast st/steel handles



Code	Designation	Lcm	Wcm	Hcm	Th.mm	Kg
3727.35		41	27,5	8	2,3	2,3

Multilayer material : st/steel Aluminium St/steel

Brushed st/steel finish
Suitable also for domestic oven.

FRENCH COLLECTION

Multilayer stainless steel AFFINITY
All heat sources including induction
Riveted cast stainless steel handles FRENCH COLLECTION
inspired by Parisian monuments

FOR ORIGINAL BUFFET PRESENTATION
OR SERVICE ON TABLE



FRENCH COLLECTION AFFINITY



Code	Designation	Øcm	Hcm	Liters.	Th.mm	Bottom ø cm	Kg
SAUCEPAN							
While stocks last							
3751.14		14	7,5	1,2	2,3	12	0,8
3751.16		16	8	1,8	2,3	13	0,95
3751.20		20	10	3,4	2,3	17	1,38
CONICAL SAUTE-PAN							
While stocks last							
3753.24		24	8	3	2,3	17	1,34

The French Collection - Celebrated landmarks bring memories to life every time you use your cookware 'made in France' The handles are inspired by Parisian monuments and bring design along with ergonomomy.

As a guarantee of strength, the riveting technique of the cast st/steel handles of the de Buyer French Collection is the same as the assembly of metal parts in the famous French « Iron Lady ».

FRENCH COLLECTION AFFINITY - lid



Code	Designation	Øcm	Th.mm	Kg
LID				
While stocks last				
3754.14		14	1	0,25
3754.16		16	1	0,27
3754.18		18	1	0,32
3754.20		20	1	0,38

The French Collection - Celebrated landmarks bring memories to life every time you use your cookware 'made in France' The handles are inspired by Parisian monuments and bring design along with ergonomomy.

COOKWARE ALCHIMY

Thick multi-layer stainless steel cookware - 3 layers

Durable, robust, professional-quality product

Conducting material: responsive and economical on all heat sources

- Controlled cooking
- Energy savings
- Even cooking

Firm, reassuring feel

Hard-wearing, non-deformable stainless steel handles

French-style closed, watertight stainless steel tube handle

Handles solidly attached with rivets

Easy to use

Pouring edge and inside graduations

All heat sources + INDUCTION and oven

Brush polished

ALCHIMY



Made in France



Saucepan Alchimy

new
2021

Code	Designation	Øcm	Liters.	Th.mm
3601.14		14	1	2,3
3601.16		16	1,5	2,3
3601.18		18	2	2,3
3601.20		20	2,5	2,3
3601.24		24	5	2,3





Straight sauté-pan Alchimy

new
2021



Code	Designation	Øcm	Th.mm	Bottom ø cm
3602.24		24	2,7	3
3602.28		28	2,7	4,5

This straight-rimmed sauté-pan is perfect for quickly browning food. Its shape assures that the humidity produced will evaporate quickly and that the juices will caramelize thoroughly.

Rounded sauté-pan with handle Alchimy

new
2021



Code	Designation	Øcm	Th.mm	Perso
3603.16		16	2,3	0,5
3603.24		24	2,3	2,5

This is the essential tool for boiling and reducing sauces. A base that is small in diameter for prompt heating and a wide rim for proper evaporation of the humidity produced. Thanks to this vessel, you will be able to prepare unsurpassable sauces.

Stainless steel frypan Alchimy

new
2021



Code	Designation	Øcm	Th.mm
3604.20		20	2,7
3604.24		24	2,7
3604.28		28	2,7
3604.32		32	2,7

This stainless steel frying pan is ideal for quickly frying and grilling meat, thanks to its ability to rapidly increase in temperature. The quality of stainless steel used to construct

this frying pan qualifies it as a strong ally in the quest to caramelize your meat.





Stewpan without lid Alchimy

new
2021



Code	Designation	Øcm	Liters.
3605.16		16	1,5
3605.20		20	2,5
3605.24		24	5
3605.28		28	7

Contrary to other kitchenware, this stewpan conserves humidity thanks to its high sides. Therefore, it is suitable for heating large quantities of water, simmering, etc.



Stainless steel steamcooker



Code	Designation	Øcm	Kg
3675.24		24	0,66

Steaming is a quick operation with this stainless steel steamer. Fits to the pan of the stainless steel and copper cookware. Equipped with an handle to remove it easily.

Tip from the chef: to make your vegetables glisten, plunge them into cold water once they are cooked.

Wok Alchimy

new
2021

Code	Designation	Øcm	Lcm	Liters.	Th.mm	Bottom ø cm	Kg
3608.32		32		4,5	2,7	16,5	
3329.10	Grid for wok ø 32 cm		34,5				0,14



For all hotplates including induction hobs

Glass lid with stainless steel knob



Code	Designation	Øcm	Kg
3429.14		14	0,24
3429.16		16	0,29
3429.18		18	0,35
3429.20		20	0,41
3429.24		24	0,58
3429.28		28	0,74
3429.32		32	1,1

These glass lids with stainless steel button fit the range .
Suitable for oven cooking.



Stainless steel lid



Code	Designation	Øcm	Kg
3509.14		14	0,13
3509.16		16	0,16
3509.18		18	0,18
3509.20		20	0,21
3509.24		24	0,3
3509.28		28	0,43
3509.32		32	0,66

Suitable for all range products

**STAINLESS STEEL COOKWARE MILADY
PRO QUALITY**

Ergonomic riveted handle made of cast stainless steel
 = good hand grip without tiredness
 Large thick magnetic bottom
 All heat sources + induction
 Perfect heat spreading on the whole bottom
 Gloss polished

MILADY



Stainless steel stewpan MILADY with glass lid



Code	Designation	Øcm	Hcm	Liters.	Th.mm	Bottom ø cm	Kg
3427.20	Stewpan with glass lid	20	10	3	0,8	17,8	1,7
3427.24	Stewpan with glass lid	24	12	5,4	0,8	19,5	2,19
3427.28	Stewpan with glass lid	28	14	8	0,8	25	2,86

The range MILADY is extending with this elegant stainless steel stewpan. It is equipped with 2 large ergonomic st/steel handles and a glass lid.

Stainless steel steamcooker



Code	Designation	Øcm	Kg
3675.24		24	0,66

Steaming is a quick operation with this stainless steel steamer. Fits to the pan of the stainless steel and copper cookware. Equipped with an handle to remove it easily.
 Tip from the chef: to make your vegetables glisten, plunge them into cold water once they are cooked.

Stainless steel frypan MILADY with riveted cast st/steel handle



Code	Designation	Øcm	Hcm	Liters.	Th.mm	Bottom ø cm	Kg
3412.24		24	4,8	1,2	0,8	17,5	1,24
3412.28		28	5,3	1,8	0,8	21	1,64

Stainless steel saucepan MILADY with riveted cast st/steel handle



Code	Designation	Øcm	Hcm	Liters.	Th.mm	Bottom ø cm	Kg
3410.14		14	7	1,2	0,8	12	0,64
3410.16		16	8	1,6	0,8	14	0,7
3410.18		18	9	2,2	0,8	15,8	0,89
3410.20		20	10	3	0,8	17,8	1,1
3410.03	Set of 3 saucepans ø 16-18-20 cm						3,15
3410.04	Set of 4 saucepans ø 14-16-18-20 cm				0,8		3,83



Discover the 'Milady de Buyer', a new pro quality stainless steel cookware which is assembled with a new cast st/steel riveted handle. Designed by de Buyer, this handle brings design along with ergonomomy and solidity. Saucepans and

frypans of the range are equipped with a magnetic bottom which allows a perfect heat spreading on all heat sources.

Stainless steel sauté-pan MILADY with riveted cast st/steel handle



Code	Designation	Øcm	Hcm	Liters.	Th.mm	Bottom ø cm	Kg
3411.24		24	8	3	0,8	17,7	1,1

Glass lid with stainless steel knob



Code	Designation	Øcm	Kg
3429.14		14	0,24
3429.16		16	0,29
3429.18		18	0,35
3429.20		20	0,41
3429.24		24	0,58
3429.28		28	0,74

These glass lids with stainless steel button fit the MILADY range of pans and sauté pans (not for round frypans). Suitable for oven cooking.



PRIM'APPETY

STAINLESS STEEL COOKWARE PRIM'APPETY PROFESSIONAL Stainless steel - Satin polished

Magnetic sandwich bottom - For all heat sources + INDUCTION
Welded handles - Easy cleaning - Dishwasher safe



Saucepan Prim'Appety



Code	Designation	Øcm	Hcm	Liters.	Th.mm	Kg
3501.04	Set of 4 saucepans ø 14-16-18-20 cm				0,8	3,3
3501.12		12	6	0,7	0,8	0,44
3501.14		14	7	1	0,8	0,6
3501.16		16	7,5	1,6	0,8	0,7
3501.18		18	9	2,2	0,8	0,9
3501.20		20	9	3	0,8	1,07
3501.24		24	11	5,4	0,8	1,55
3501.28	with 2 handles	28	13	8	0,8	2,4

Totally stainless steel. Sandwich bottom. Pouring lips. All heat sources including induction. Easy to clean. Satin polished. Welded handles.

Round stainless steel frypan Prim'Appety



Code	Designation	Øcm	Hcm	Th.mm	Kg
3504.20		20	5	0,6	1,12
3504.24		24	5	0,6	1,35
3504.28		28	5	0,8	1,45
3504.32	With 2 handles	32	6,5	0,8	2,5



Rounded sauté-pan Prim'Appety

Sauté-pan Prim'Appety , st. steel handle



Code	Designation	Øcm	Hcm	Th.mm	Kg
3503.16		16	6	0,8	0,65
3503.18		18	6,5	0,8	0,85
3503.20		20	7	0,8	1,1
3503.24		24	8	0,8	1,3
3503.28		28	10	0,8	1,5

Code	Designation	Øcm	Hcm	Th.mm	Kg
3502.20		20	6	0,8	1
3502.24		24	6	0,8	1,2
3502.28		28	6	0,8	1,4

Stewpan without lid Prim'Appety

Code	Designation	Øcm	Hcm	Liters.	Th.mm	Kg
3505.20		20	10	3,1	0,8	1,16
3505.24		24	12	5,4	0,8	1,66
3505.28		28	14	8,6	0,8	2,13
3505.32		32	16	13,5	0,8	3,2
3505.36		36	18	18,3	0,8	4
3505.40		40	20	25	1	5,7
3505.45		45	22,5	33	1	7,6
3505.50		50	25	43,4	1	8,9



Totally stainless steel. Thick sandwich bottom. Pouring lips.
Satin polished. Welded handles.
All heat sources including induction. Easy to clean.



High stewpan Prim'Appety without lid



Code	Designation	Øcm	Hcm	Liters.	Th.mm	Kg
3506.20		20	13	4	0,8	1,26
3506.24		24	14,5	6,6	0,8	1,8
3506.28		28	18	11,1	0,8	2,3
3506.32		32	20	16,1	0,8	3,8
3506.36		36	22	22,4	0,8	4,5
3506.40		40	25	31,4	1	6
3506.50		50	30	58,9	1	9,2

Stockpot without lid Prim'Appety



Code	Designation	Øcm	Hcm	Liters.	Th.mm	Kg
3507.20		20	20	6,25	0,8	1,7
3507.24		24	24	11	0,8	2,1
3507.28		28	28	17	0,8	2,9
3507.32		32	32	25	0,8	4,4
3507.36		36	36	36	0,8	5,1
3507.40		40	40	45	1	6,4
3507.45		45	45	69	1	9
3507.50		50	50	100	1	11

Totally stainless steel. Sandwich bottom. Pouring lips. All heat sources including induction. Easy to clean. Satin polished. Welded handles.

Stainless steel steamcooker



Code	Designation	Øcm	Kg
3675.24		24	0,66

Steaming is a quick operation with this steamer. Suitable for PRIM'APPETY stewpans. Tip from the chef: to make your vegetables glisten, plunge them into cold water once they are cooked.

Lid Prim'Appety



Code	Designation	Øcm	Kg
3509.14		14	0,13
3509.16		16	0,16
3509.18		18	0,18
3509.20		20	0,21
3509.24		24	0,3
3509.28		28	0,43
3509.32		32	0,66
3509.36		36	0,8
3509.40		40	0,96
3509.45		45	1,12
3509.50		50	1,8

Suitable for all range products

Stainless steel rounded WOK - Special induction hob



Code	Designation	Øcm	Lcm	Hcm	Th.mm	Kg
3122.36	Flat rim	36	63,5	9,5	1,5	1,3
	Inner pan: polished					
	Outer pa : gloss polished					

Typical Asian rounded form adapted to the wok induction cooker. Enables to seal and cook food with little fat for a dietetic and natural Asian cuisine. Optimized weight of the wok to cook effortlessly. Thanks to the thickness of 15/10° the wok is both solid

and light. The cold ergonomic riveted handle made of stainless steel allows optimum grip without tiredness.

Stainless steel stand for hemispherical wok



Code	Designation	Øcm	Hcm	Th.mm	Kg
3122.00		24	3,65	1	0,25

Suitable for rounded woks 3122.90 and 5114.35. Enables to use these woks on standard flat induction hotplates. Thanks of the special form with its handle support, the wok is steady on the plate.

"Induction" fish kettle

Code	Designation	Lcm	Wcm	Hcm	Th.mm	Kg
3449.62N	"Standard", st. steel handles - L. 60 cm	60	16,5	9,5	0,8	1,92



The fish kettle remains the ideal utensil for cooking whole fish to give a perfect appearance. The internal grid allows you to remove the fish without its breaking. All hotplates, including induction.

Bain-marie without lid



Code	Designation	Øcm	Hcm	Liters.	Th.mm	Kg
3111.12		12	11,5	1,3	0,8	0,42
3111.14		14	14	2,1	0,8	0,51
3111.16		16	16	3,2	0,8	0,73
3111.18		18	18	4,6	0,8	0,86
3111.20		20	20	6,3	0,8	1

The bain-marie cooking pot is made from stainless steel. Its shape means it can be placed inside a water container (pan), and it allows milk, chocolate, sauces, etc., to be cooked using the bain-marie process. The lid is sold separately

Food storage canister, without lid



Code	Designation	Øcm	Hcm	Liters.	Th.mm	Kg
3390.14		14	12	1,7	0,8	0,49
3390.16		16	13	2,5	0,8	0,59
3390.20		20	16,5	5	0,8	0,91
3390.24		24	20	8	0,8	1,28
3390.28		28	23	14	0,8	1,72
	While stocks last					
3390.32		32	27	22	0,8	2,28
	While stocks last					

This stainless steel canister with cupped handles allows food to be stored in perfect safety. It can be used as a container for warming food using the bain-marie process.

Bain-marie cooker



The bain-marie cooker consists of a hollow stainless steel shell in which water is heated. It enables you to heat at lukewarm temperatures for melting chocolate or keeping sauces warm. It has a handle, which makes it easy to use. Suitable on all heat sources incl. induction hobs.

Code	Designation	Øcm	Hcm	Liters.	Th.mm	Kg
3437.16N	With handle and double st. steel body	16	12,5	1,5	1	0,97

CUISINE BOX PRO - Silicone box for steam cooking in oven



The De Buyer silicone "Cuisine Box" allows you to steam your food quickly and healthily while conserving their full flavour (vegetables, fish, white meat, fruit) for use in traditional and microwave ovens. Its innovative design optimises cooking and makes it really easy to use.

- Secure locking system
- Safe and easy lifting thanks to the handles
- Spout to drain off cooking juices
- Excellent support thanks to springs

Code	Designation	Lcm	Wcm	Hcm	Liters.	Kg
1988.20	While stocks last	19	12	3,8	0,75	0,17





cookware REMOVABLE LINE

Cook, simmer or seal,
Stainless steel, steel or nonstick
move from one line to another in a trice.
3 cookwares, 3 materials, 3 uses and
only one practical, comfortable and ergonomic handle.

- 74 -

Stainless steel with sandwich bottom
TWISTY

- 76 -

Nonstick
CHOC INTENSE

- 77 -

Steel MINERAL B





STAINLESS STEEL COOKWARE TWISTY
Removable line

Large thick magnetic bottom INDUCTION - All heat sources + induction
Perfect heat spreading on the whole bottom
Gloss polished - Pouring lips & Rounded edges
Perfect hygiene and easy cleaning

Removable "Soft Touch" handle



Code	Designation	Kg
8359.00	Black	0,12
8359.20	Green	0,12
8359.30	Orange	0,12
8359.40	Red	0,12

This handle is suitable for the 3 removable cookware ranges :
- Stainless steel TWISTY
- Nonstick aluminium CHOC INTENSE
- Steel MINERAL B

Stainless steel saucepan TWISTY without handle



Code	Designation	Øcm	Hcm	Liters.	Th.mm	Bottom ø cm	Kg
3491.14		14	7	1,2	0,8	12	0,44
3491.16		16	8	1,6	0,8	14	0,53
3491.18		18	9	2,2	0,8	15,8	0,72
3491.20		20	10	3	0,8	17,8	0,85
3491.24		24	12	5,4	0,8	19,5	1,28
3491.28	Use only with both silicone handles	28	14	8	0,8	25	1,95
3491.03	Set of 3 saucepans ø 16-18-20 cm without handles				0,8		2,49
3491.04	Set of 4 saucepans ø 14-16-18-20 cm supplied with an handle & 2 silicone handles - black				0,8		3,11



Stainless steel steamcooker



Code	Designation	Øcm	Kg
3675.24		24	0,66

Steaming is a quick operation with this stainless steel steamer. Fits to the pan of the stainless steel and copper cookware. Equipped with an handle to remove it easily.
Tip from the chef: to make your vegetables glisten, plunge them into cold water once they are cooked.



Stainless steel sauté-pan TWISTY

Stainless steel frypan TWISTY, without handle



Code	Designation	Øcm	Hcm	Liters.	Th.mm	Bottom ø cm	Kg
3495.24		24	8	3	0,8	17,7	0,98

Code	Designation	Øcm	Hcm	Liters.	Th.mm	Bottom ø cm	Kg
3493.24		24	4,8	1,2	0,8	17,5	0,88
3493.28		28	5,3	1,8	0,8	21	1,22

Glass lid



Code	Designation	Øcm	Hcm	Kg
4112.14		14	6,3	0,24
4112.16		16	6,3	0,3
4112.18		18	6,3	0,35
4112.20		20	6,8	0,41
4112.24		24	7,5	0,58
4112.28		28	7,5	0,74

Possible oven cooking 200°C max.

Set of 2 black silicone handles



Code	Designation	Kg
8360.00	black	0,04



Removable line

CHOC INTENSE Removable nonstick line - FORGED ALUMINIUM

NONSTICK COOKWARE

Removable Soft Touch comfortable and ergonomic handle
 All heat sources + induction
 Made in France

**CHOC
 INTENSE**



Nonstick frypan CHOC INTENSE, without handle

**new
 2021**



Code	Designation	Øcm	Th.mm	Bottom ø cm	Kg
8740.20		20	4	14	0,6
8740.24		24	4	16,6	0,8
8740.28		28	4	20,6	1,1
8740.32		32	4	22	1,3

Nonstick sauté pan CHOC INTENSE, without handle

**new
 2021**



Code	Designation	Øcm	Th.mm	Bottom ø cm	Kg
8748.24		24	4	16,6	1
8748.28		28	4	22	1,3



Nonstick crêpe pan CHOC INTENSE, without handle

**new
 2021**



Code	Designation	Øcm	Th.mm	Perso	Kg
8745.26		26	4	18	0,73
8745.30		30	4	22	1





**MINERAL B STEEL COOKWARE - BEESWAX FINISH
REMOVABLE LINE**

Suitable for all hotplates including INDUCTION

Removable Soft Touch comfortable and ergonomic handle
All heat sources + induction

Removable "Soft Touch" handle

Code	Designation	Kg
8359.00	Black	0,12
8359.20	Green	0,12
8359.30	Orange	0,12
8359.40	Red	0,12



This handle is suitable for the 3 removable cookware ranges :
 - Stainless steel TWISTY
 - Nonstick aluminium CHOC INTENSE
 - Steel MINERAL B ELEMENT



Steel frypan MINERAL B, without handle



Code	Designation	Øcm	Th.mm	Bottom ø cm	Kg
5630.20		20	2,5	14	0,86
5630.24		24	2,5	17,5	1,23
5630.28		28	3	21	1,93

Steel sauté pan MINERAL B, without handle



Code	Designation	Øcm	Hcm	Liters.	Th.mm	Bottom ø cm	Kg
5634.24		24	7,8	2,5	2,5	16,5	1,72

Steel crepe pan MINERAL B, without handle



Code	Designation	Øcm	Hcm	Th.mm	Bottom ø cm	Kg
5635.26		26	1,3	2,5	22,5	1,24



de Buyer 
MADE IN FRANCE

de Buyer

THE EXCELLENCE OF COPPER

Copper is a leading material for kitchen use and loved by professionals and keen amateurs as well. It conducts heat quickly and evenly and is perfect for thickening sauces and cooking when particular care is required.

The utensil bodies are made of a colaminated material (90% copper; 10% stainless steel). The copper is hand-polished using traditional methods - its gentle, soothing aura making it the perfect companion for your table.

- 80 -

Copper stainless steel Induction
PRIMA MATERA
cast stainless steel handles

- 84 -

Copper stainless steel Induction
PRIMA MATERA
cast steel handles

- 86 -

Copper stainless steel **INOCUIVRE**
cast stainless steel handles

- 90 -

Copper stainless steel **INOCUIVRE**
cast steel handles

- 92 -

Copper stainless steel **INOCUIVRE**
brass handles



INOUCIVRE INDUCTION

- Copper outside 90% = excellent heat diffusion
- Stainless steel inside 10% = matchless hygiene - ease of use
- Ergonomic cast stainless steel riveted handles
- All heat sources including induction
- Made in France

PRIMA MATERA



Saucepan with magnetic bottom INDUCTION



Code	Designation	Øcm	Hcm	Liters.	Th.mm	Bottom ø cm	Kg
6206.14		14	7,3	1,2	2	12	1,06
6206.16		16	8,3	1,8	2	13,5	1,37
6206.18		18	9,3	2,5	2	15,5	1,66
6206.20		20	10,5	3,3	2	17	2,06
6206.24		24	12,4	6	2	22	2,75

This saucepan made of copper and stainless steel on the inside enables to enjoy the exceptional degree of conductivity of copper on all types of heat sources, including INDUCTION, thanks to its magnetic bottom. The cast stainless steel ergonomic handle are firmly riveted. The st/steel lid 3709 is suitable for the PRIMA MATERA pans (except frypan).

Sauté pan with magnetic bottom INDUCTION



Code	Designation	Øcm	Hcm	Liters.	Th.mm	Bottom ø cm	Kg
6230.16		16	5,5	1	2	13,5	1,13
6230.20		20	5,8	1,8	2	17,5	1,48
6230.24		24	6,6	3	2	22	2,06

The st/steel lid 3709 is suitable for the PRIMA MATERA pans (except frypan).



Frypan with magnetic bottom INDUCTION and stainless steel handle



Code	Designation	Øcm	Hcm	Th.mm	Bottom ø cm	Kg
6224.20		20	4	2	13,5	1,3
6224.24		24	4	2	16,5	1,41
6224.28		28	4	2	20	1,86
6224.32		32	5,5	2	23	2,38

Conical sauté pan with magnetic bottom INDUCTION



Code	Designation	Øcm	Hcm	Liters.	Th.mm	Bottom ø cm	Kg
6236.20		20	7,2	1,7	2	13	1,32
6236.24		24	8,2	3,1	2	16,3	2,75

This flared sauté pan is ideal for boiling down cooking juices. That's often one of the reasons it's the professionals' first choice. The st/steel lid 3709 is suitable for the PRIMA MATERA pans (except frypan).

Stainless steel lid



Code	Designation	Øcm	Th.mm	Kg
3709.14N		14	1	0,24
3709.16N		16	1	0,28
3709.18N		18	1	0,33
3709.20N		20	1	0,39
3709.24N		24	1	0,51
3709.28		28	1	0,65

This lid is made to fit all kitchenware in this range, except round frypans.



Stockpot with magnetic bottom INDUCTION and st/steel lid



Code	Designation	Øcm	Hcm	Liters.	Th.mm	Bottom ø cm	Kg
6244.20		20	18	5,7	2	22	3,1

This stockpot is a must for simmering family dishes and is the ideal utensil for preparing bouillabaisse, Irish stew, couscous ingredients, vegetable broth, etc.

High stewpan with magnetic bottom INDUCTION and st/steel lid



Code	Designation	Øcm	Hcm	Liters.	Th.mm	Bottom ø cm	Kg
6243.24		24	16,5	7,5	2	22	3,6



Sauté pan and st/steel lid



Rounded sauté pan with 2 st/steel handles



Code	Designation	Øcm	Hcm	Liters.	Th.mm	Bottom ø cm	Kg
6241.20		20	6	1,8	2	17,5	1,9
6241.24		24	6,8	3,1	2	22	2,51
6241.28		28	9,2	4,9	2	25	3,12

Code	Designation	Øcm	Hcm	Liters.	Th.mm	Bottom ø cm	Kg
6232.28	delivered with stainless steel lid	28	10	4,9	2	20,5	3,12

This sauté pan made of copper and stainless steel on the inside has a magnetic bottom and is adapted to all hotplates, including INDUCTION. The riveted handles are made of cast stainless steel.

COPPER Massive copper Induction PRIMA MATERA Induction PRIMA MATERA, cast stainless steel handle

Stewpan with magnetic bottom INDUCTION and st/steel lid



Code	Designation	Øcm	Hcm	Liters.	Th.mm	Bottom ø cm	Kg
6242.16		16	8,8	1,8	2	13,5	1,54
6242.20		20	10,3	3,3	2	17	2,21
6242.24		24	12,3	5,4	2	22	3,22
6242.28		28	13,5	8	2	25	4,07

This stewpan made of copper and stainless steel on the inside has a magnetic bottom and is adapted to all hotplates, including INDUCTION. The riveted handles are made of cast stainless steel.

WOK with 2 cast st/steel handles



Code	Designation	Øcm	Lcm	Hcm	Liters.	Th.mm	Bottom ø cm	Kg
6247.32	ø bottom 10 cm	32		12,5	4	2	17	2,5
3329.10	Grid for wok ø 32 cm		34,5					0,14
3429.32	Glass lid with stainless steel handle	32						1,1

Care :

- **The COPPER outside** : the colour changes on a heat sources. Use a special copper cleaner to give brilliance back to a copper utensil. Never use a metal sponge.
- **The STAINLESS STEEL inside** : easy care with a sponge and washing-up liquid.
- If you burn food in your utensil Inocuvre, soak during half a day with water and washing-up liquid.
- Cleaning in the dishwasher is not recommended. The copper utensils with cast steel handles may rust.

Stainless steel steamcooker



Code	Designation	Øcm	Kg
3675.24		24	0,66

Steaming is a quick operation with this steamer with fits on the copper pans. Equipped with an handle. Tip from the chef: to make your vegetables glisten, plunge them into cold water once they are cooked.

COPPER STAINLESS STEEL INDUCTION

- Copper outside 90% = excellent heat diffusion
- Stainless steel inside 10% = matchless hygiene - ease of use
- Ergonomic cast steel riveted handles
- All heat sources including induction
- Made in France

PRIMA
MATERA



Saucepan with magnetic bottom INDUCTION, cast iron handle



Code	Designation	Øcm	Hcm	Liters.	Th.mm
6306.14		14	7,3	1,2	2
6306.16		16	8,3	1,8	2
6306.18		18	9,3	2,5	2

This design of pan is the utensil professional kitchens can't do without. It is especially suited to boiling down (sauce making...). The walls are stainless steel on the inside. The cast steel handle is firmly riveted. 2mm-thick (90% copper and 10% stainless steel).

Sauté pan with magnetic bottom INDUCTION, cast iron handle



Code	Designation	Øcm	Hcm	Liters.	Th.mm
6330.24		24	6,6	3	2

The copper lid6463 is suitable for this PRIMA MATERA pans with cast steel handles (except frypan).



Rounded sauté pan INDUCTION with copper lid, cast iron handles



Code	Designation	Øcm	Hcm	Liters.	Th.mm
6332.28		28	10	4,9	2

Conical sauté pan with magnetic bottom INDUCTION, cast iron handle



Code	Designation	Øcm	Hcm	Liters.	Th.mm
6336.20		20	7,2	1,7	2

This flared sauté pan is ideal for boiling down cooking juices. That's often one of the reasons it's the professionals' first choice. The st/steel lid 3709 is suitable for the PRIMA MATERA pans (except frypan).

Frypan with magnetic bottom INDUCTION, cast iron handle



Code	Designation	Øcm	Hcm	Th.mm
6324.24		24	4	2
6324.28		28	4	2
6324.32		32	5,5	2

Stewpan with magnetic bottom INDUCTION with lid , cast iron handles



Code	Designation	Øcm	Hcm	Liters.	Th.mm
6342.16		16	8,8	1,8	2
6342.20		20	10,3	3,3	2
6342.24		24	12,3	5,4	2
6342.28		28	13,5	8	2

The stewpan has high sides, which allows you to simmer food or cook large volumes of liquid, vegetables, etc. The moisture stays in the pot. The walls are stainless steel on the inside. The handles are firmly riveted.

INOCUIVRE

- Copper outside 90% = excellent heat diffusion
- Stainless steel inside 10% = matchless hygiene - ease of use
- Ergonomic cast stainless steel riveted handles
- All heat sources except induction
- Made in France

INOCUIVRE



Saucepan



Code	Designation	Øcm	Hcm	Liters.	Th.mm	Kg
6406.14		14	7,8	1,2	1,5	0,63
6406.16		16	9	1,8	1,5	0,97
6406.18		18	10	2,5	1,5	1,37
6406.20		20	10,7	3,3	1,5	1,9

A new 2mm-thick (90% copper and 10% stainless steel) professional and smart line INOCUIVRE.

Round frypan



Code	Designation	Øcm	Hcm	Th.mm	Kg
6424.20		20	3,5	2	0,95
6424.24		24	3,7	2	1,3
6424.28		28	3,6	2	1,55
6424.32		32	5	2	2,2

While stocks last

It is the perfect frypan for quick cooking. It will also be an elegant product in your kitchen thanks to its design.

Sauté pans



Code	Designation	Øcm	Hcm	Liters.	Th.mm	Kg
6430.16	Straight sauté-pan	16	5,8	1	1,5	0,75
6430.20	Straight sauté-pan	20	6,5	1,8	1,5	1,08
6430.24	Straight sauté-pan	24	7,5	3	2	2
6436.20	Conical sauté-pan	20	7,2	1,7	1,5	1,32
6436.24	Conical sauté-pan	24	7,5	3,1	2	1,8

Made up of 90% copper and 10% stainless steel, this sauté-pan will ensure you a good heat convection and is easy to clean.

Wok with 2 cast st/steel handles



Code	Designation	Øcm	Lcm	Hcm	Liters.	Th.mm	Kg
6440.32	wok	32		12	4	2	2,4
3329.10	Grid for wok ø 32 cm		34,5				0,14
3429.32	Glass lid for wok	32					1,1

Sauté pan with 2 cast stainless steel handles with lid



Code	Designation	Øcm	Hcm	Liters.	Th.mm	Kg
6441.20		20	6,2	1,8	1,5	1,5
6441.24		24	7	3	2	2,38
6441.28		28	9	4,9	2	3,36

With a 2 mm thickness this sauté pan allows quick browning of food. It is really practical and elegant.

Stewpan with 2 cast stainless steel handles with lid



Code	Designation	Øcm	Hcm	Liters.	Th.mm	Kg
6442.16		16	9	1,8	1,5	1,28
6442.20		20	11	3,3	1,5	2,23
6442.24		24	12	5,4	2	3,25
6442.28		28	13,5	8	2	3,96

The stewpan has high sides which allows you to simmer food or cook large volumes of liquid, vegetables, etc. The moisture stays in the pot. The material that composes it offers an extraordinary cooking quality.

Stockpot with 2 cast stainless steel handles with lid



Code	Designation	Øcm	Hcm	Liters.	Th.mm	Kg
6444.20		20	18	5,7	2	3

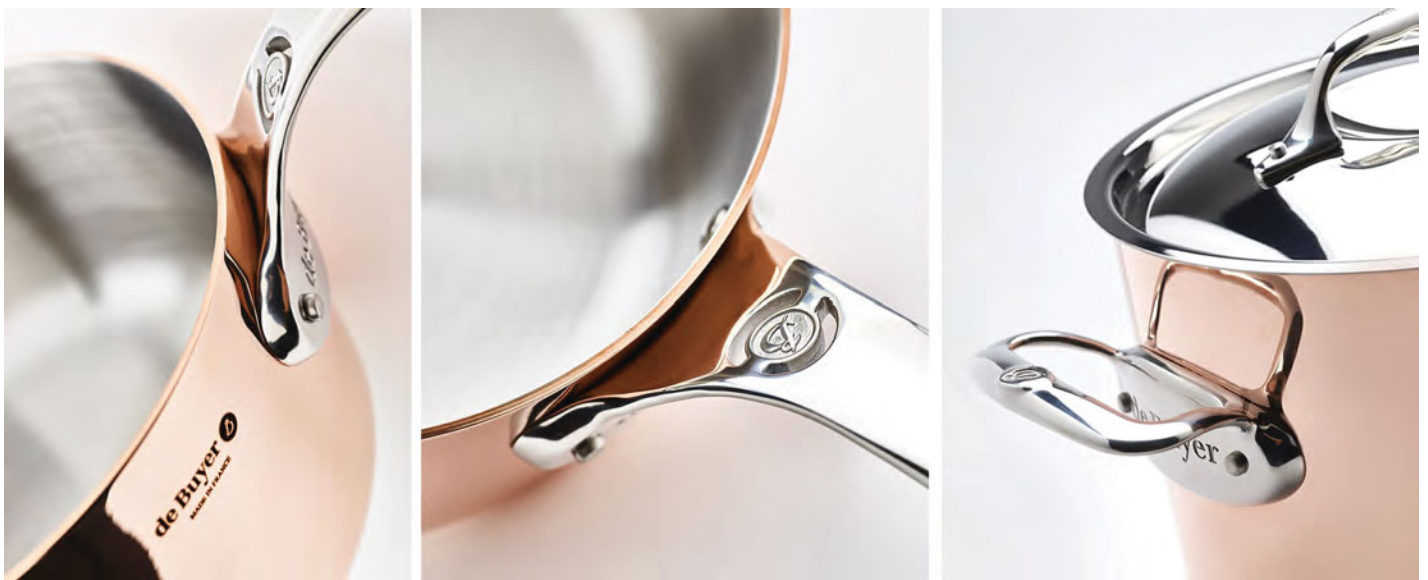

Stainless steel lid



Code	Designation	Øcm	Th.mm	Kg
3709.14N		14	1	0,24
3709.16N		16	1	0,28
3709.18N		18	1	0,33
3709.20N		20	1	0,39
3709.24N		24	1	0,51
3709.28		28	1	0,65

This lid is made to fit all kitchenware in this range, except round frypans.

Oval stewpan with 2 cast stainless steel handles & lid - 2 mm thick



Code	Designation	Lcm	Wcm	Hcm	Liters.	Th.mm	Kg
6426.30	Stewpan with lid	30	22	13	6,5	2	3,6

Oval fish frypan L. 32 cm - handle on the short axis



Code	Designation	Lcm	Wcm	Hcm	Th.mm	Kg
6425.32		32	23	4,8	2	1,81
	While stocks last					

Mini blinis pan ø 10 cm - 2-mm thick



Code	Designation	Øcm	Th.mm	Kg
6424.10		10	2	0,26
	While stocks last			

Roasting-pan - copper st/steel - with 2 riveted cast st/steel handles



Code	Designation	Lcm	Wcm	Hcm	Th.mm	Kg
6427.35	Roasting pan	41	27	8	2	2,2

Multilayer material : copper alu st/steel
 Handles made of cast stainless steel
 Suitable also for domestic oven.





Saucepan, cast-iron handle



Code	Designation	Øcm	Hcm	Liters.	Th.mm	Kg
6460.01	Set of 5 - ø12-20 cm					8,28
6460.12		12	7	0,8	1,5	0,77
6460.14		14	7,5	1,2	1,5	1,23
6460.16		16	9	1,8	1,5	1,3
6460.18		18	9	2,5	1,5	1,61
6460.20		20	10,8	3,3	1,5	1,96

This design of pan is the utensil professional kitchens can't do without. It is especially suited to boiling down (sauce making...). The walls are stainless steel on the inside. The cast steel handle is firmly riveted. 2mm-thick (90% copper and 10% stainless steel). All

hotplates except induction.

Sauté-pan, frypan, cast iron handle



Code	Designation	Øcm	Hcm	Liters.	Th.mm	Kg
6464.16	Conical sauté-pan, no lid	16	6	0,9	1,5	0,9
6464.20	Conical sauté-pan, no lid	20	7	1,7	1,5	1,38
6464.24	Conical sauté-pan, no lid	24	8	2,9	2	1,93
6462.16	Sauté-pan, no lid	16	5,5	1	1,5	0,84
6462.20	Sauté-pan, no lid	20	6	1,8	1,5	1,45
6462.24	Sauté-pan, no lid	24	7	3,1	2	2,15
6462.28	Sauté-pan, no lid	28	8,5	4,9	2	2,85
6465.20	Frypan	20	3,4		2	1,04
6465.24	Frypan	24	4,2		2	1,48
6465.28	Frypan	28	3,6		2	1,7
6465.32	Frypan	32	5		2	2,44

Heavy duty sauté pans and frying pans are utensils professional kitchens can't do without. The straight-sided sauté pan allows quick browning of food, the tapered sauté pan is ideal for boiling down sauces, and the frying pan turns out to be perfect for frying, searing, and flambéing food. The walls are stainless steel on the inside. The cast steel handle is firmly riveted. All hotplates except induction.

Lid, cast-iron handle



Code	Designation	Øcm	Th.mm	Kg
6463.12		12	1,2	0,17
6463.14		14	1,2	0,21
6463.16		16	1,2	0,27
6463.18		18	1,2	0,35
6463.20		20	1,2	0,41
6463.24		24	1,2	0,68
6463.28		28	1,2	0,8

The inside of the lid is stainless steel. The handle is made from cast steel and is firmly riveted.



Stewpan with lid, cast-iron handles



Code	Designation	Øcm	Hcm	Liters.	Th.mm	Kg
6466.16		16	8,8	1,8	1,5	1,5
6466.20		20	10,5	3,3	1,5	2
6466.24		24	12,5	5,4	2	3,24
6466.28		28	13,5	8	2	4,05

The stewpan has high sides, which allows you to simmer food or cook large volumes of liquid, vegetables, etc. The moisture stays in the pot. The walls are stainless steel on the inside. The handles are firmly riveted. All hotplates except induction.

High stewpan with lid



Code	Designation	Øcm	Hcm	Liters.	Th.mm	Kg
6467.24		24	18,5	7,5	2	3,67

All hotplates except induction.

Stockpot with lid



Code	Designation	Øcm	Hcm	Liters.	Th.mm	Kg
6468.20		20	18,5	5,7	2	2,9

All hotplates except induction.

INOCUIVRE



INOCUIVRE Copper 90% Stainless steel 10%

Ergonomic brass riveted handles

Suitable for cooking as well as presentation on table and making flambés

All heat sources except induction



Saucepan



Code	Designation	Øcm	Hcm	Liters.	Th.mm	Kg
6445.01	Set of 5 - ø12-20					4,83
6445.10		10	5,2			0,33
6445.12		12	6	0,8	1,5	0,5
6445.14		14	7	1	1,5	0,63
6445.16		16	8,5	1,6	1,5	0,8
6445.18		18	9	2,5	1,5	0,99
6445.20		20	10	3,5	1,5	1,21

This design of pan is especially well adapted to the table and making flambés or can be used simply to decorate the kitchen interior. It can also be used for cooking on medium-power heat

sources. The walls are stainless steel on the inside, which makes for easy upkeep and removes the need for re-tinning. Riveted brass handle.

Sauté-pan without lid



Code	Designation	Øcm	Hcm	Liters.	Th.mm	Kg
6448.16		16	5	1	1,5	0,75
6448.20		20	6	1,8	1,5	0,94
6448.24		24	6,5	3	2	1,81

The straight-sided sauté pan allows quick browning of food and proves ideal for serving and for flambéing. The walls are stainless steel on the inside, which makes for easy upkeep and removes the need for re-tinning. The brass handle is firmly riveted.

Frypan with brass handle



Code	Designation	Øcm	Wcm	Hcm	Th.mm	Kg
6450.13	mini frypan	9,3	13	3,2		0,47
6450.20		20		3	2	0,91
6450.24		24		4	2	1,3
6450.28		28		4,5	2	1,82

These frying pans in stainless-lined copper prove perfect for frying and searing using medium-power heat sources, for flambéing food, and give a perfect appearance on the table. The skirt is stainless steel on the inside, which makes for easy upkeep and

removes the need for re-tinning. The brass handle is firmly riveted.

WOK with brass handle



Code	Designation	Øcm	Hcm	Th.mm	Kg
6432.32		30,9	8,5	2	2,25
3429.32	Glass lid with st/steel knob for wok :	32			1,1

The wok has forever been the universal Asian kitchen utensil, and it turns out to be ideal for a natural, dietetic cuisine, which needs very little fat and preserves the food's original taste. The bowl is stainless steel on the inside, which makes for easy upkeep and removes the need

for re-tinning. The brass handle is firmly riveted.

Round dish, 2 handles



Code	Designation	Øcm	Hcm	Th.mm	Kg
6449.12		12	2	2	0,34
6449.16		16	3	2	0,55
6449.20		20	3	2	0,78
6449.24		24	4,2	2	1,23

This round dish is used a lot for cooking eggs, making gratins, or perhaps for making crème brûlées. It makes for an elegant appearance on the table. The skirt is stainless steel on the inside, which makes for easy upkeep and removes the need for re-tinning.

The brass handles are firmly riveted.

Oval dish, 2 handles



Code	Designation	Lcm	Wcm	Hcm	Th.mm	Kg
6451.32		32	23	4,5	1,5	1,02
6451.36		36	26,2	4,5	1,5	1,2

The dish proves ideal for serving and for flambéing. The skirt is stainless steel on the inside, which makes for easy upkeep and removes the need for re-tinning. The brass handles are firmly riveted. Do not use directly on a heat sources.

Sauté-pan with lid, brass handles



Code	Designation	Øcm	Hcm	Liters.	Th.mm	Kg
6446.20		20	6	1,8	1,5	1,44
6446.24		24	7	3,2	2	2,48
6446.28		28	9	5,5	2	3,37

The two-handed sauté dish allows quick browning of food. It has the same uses as a one-handed sauté pan, but turns out to be more practical to handle and takes up less space when stored away or when on the burner. The walls are stainless steel on the inside.

The brass handles are firmly riveted.

Round stewpan with lid

Code	Designation	Øcm	Hcm	Liters.	Th.mm	Kg
6447.10	mini stewpan with lid	10	5,5			0,48
6447.16		16	8	1,6	1,5	1,04
6447.20		20	10	3,5	1,5	1,59
6447.24		24	11,5	5,2	2	3,13



This casserole is an elegant way of serving at the table. It can also be used for cooking on medium-power heat sources. The skirt is stainless steel on the inside, which makes for easy upkeep and removes the need for re-tinning. The brass handles are firmly riveted.

Lid

Code	Designation	Øcm	Th.mm	Kg
6454.09	Round handle	9		0,09
6454.10	Round handle	10		0,1
6454.12		11,5	1,2	0,17
6454.14		13,5	1,2	0,21
6454.16		15	1,2	0,29
6454.18		17	1,2	0,36
6454.20		19,5	1,2	0,42
6454.24		23,5	1,2	0,62
6454.28		27	1,2	0,82



The inside of the lid is stainless steel. The brass handle is firmly riveted.

Mini pans , copper st/steel with brass handles

Code	Designation	Øcm	Wcm	Hcm	Liters.	Kg
6453.09	Saucepan with lid	9		4,5	0,3	0,21
	Saucepan without lid					
6445.09		9		4,5	0,3	0,2
6445.10		10		5,2		0,33
6450.13	mini frypan	9,3	13	3,2		0,47
6447.10	mini stewpan with lid	10		5,5		0,48



The small saucepan is perfect for serving sauces. It ensures an elegant appearance. The walls are stainless steel on the inside, which makes for easy upkeep and removes the need for re-tinning. The brass handle is firmly riveted.



Copper massive conical jam pans with cast-iron handles



Code	Designation	Øcm	Hcm	Liters.	Th.mm	Kg
6200.38N	Conical jam pan, 1 mm th	38	15	9	1,2	1,5
6202.40N	Conical jam pan, 2 mm th	40	14,4	12	1,7	3,4

These copper basins are genuine traditional utensils used for bringing sugar or fruit to a boil to make jams, jellies, or preserves. The cast steel handles are firmly riveted.

Copper "Canelés Bordelais" fluted moulds



Code	Designation	Øcm	Hcm	Liters.	Th.mm	Kg
TINNED COPPER						
6820.35N		3,5	3,3	0,03	0,8	0,01
6820.45N		4,5	4,2	0,06	1	0,03
6820.55N		5,5	5	0,1	1,2	0,05

These moulds allow you to use the traditional method for making Bordeaux's famous crunchy Canelé cakes. The copper ensures perfect heat convection, which allows good caramelization of the juices and gives a delicious taste.

Copper eggwhites bowl



Code	Designation	Øcm	Th.mm	Kg
6580.20	1 ring-handle	20	1,2	0,91
6580.26N	1 ring-handle	26	1,2	1,06
6580.32	1 ring-handle	32	1,2	1,63
6581.20	With 2 handles	20	1,2	1,1
6581.26	With 2 handles	26	1,2	1,41
6581.32	With 2 handles	32	1,2	1,8

Made from solid copper, these half-round eggwhite basins are the traditional utensils used by professionals. The basins are perfect for beating egg-whites until stiff.



Copper cleaner



Code	Designation	Liters.	Kg	PU
4200.01N	150 ml	0,15	0,24	6

This cleaner gives brilliance back to your utensils. It is really easy to use: First, clean your pan. Wet the sponge with hot water and dip it in the cleaner. Rub the whole pan with the sponge. Then rinse it with hot water and dry it carefully.



MILLS

De Buyer and the mills A spicy story and a challenge taken up with relish

For two centuries, the passion for cookery, taste and Gastronomy, both local and from around the world, has driven de Buyer's manufacturing. Its savoir faire in the design and manufacturing of high-quality kitchen and patisserie utensils responds to the demands of professionals and enthusiasts for all that is good and home-made.

It has thus created its own world dedicated to the mastery of taste, so it is entirely natural that it should wish to complement its collections with mills for salt, pepper and other spices.

However, de Buyer is first and foremost a manufacturer that loves to design, innovate and use its savoir faire and experience to make its products. As a living heritage company, the business has retained its artisanal soul, its rigour and its love for work well done.

De Buyer has always wanted to offer its own collection of mills, bearing its signature.

De Buyer approached Marlux to create this collection. Both companies share the same values, an artisanal soul and a love for work well done. Marlux is a family business, founded in 1875 and is also a living heritage company that has become a major name in the history of French mill manufacturing. In 1972, it revolutionised the world of spices by inventing the nutmeg mill and, as true benchmarks, their mills featured on the finest tables because of the quality of their salt and pepper grinders, manufactured on its own machines.

The great spice adventure began in 2015 for de Buyer and the first mills began to leave the factory in 2016.

The company's mastery of materials enables de Buyer to create mills with new signature mechanisms in steel and ceramic.







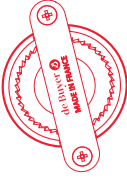

Today, the manufacturing process of the mills is part of the de Buyer company's CSR policy: the wooden mills are made of beech from sustainably managed forests and have obtained the Origine France Garantie certification.

Spices are ingredients that are inextricably linked to flavour; masterfully ground, they reveal themselves and enable us all to create our own symphonies of aromas.

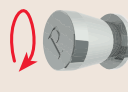

WOODEN MODELS

ACRYLIC MODELS

	PEPPER	SALT	NUTMEG	SPICES
Designed for	All types of round peppercorns Not salt	Coarse white salt not wet salt	Nutmeg only	pepper mixes and large peppercorns / seeds, white cooking salt, herbes de Provence, seeds such as cumin, poppy or sesame, fleur de caviar etc...
Type of mechanism	Steel mechanism	Stainless steel mechanism	Stainless steel mechanism	Wide standard mechanism Standard mechanism
Material	High-quality treated hardened steel	18/10 quality stainless steel	Stainless steel	Ceramic
Appearance of the mechanism				
Adjustment of the grind	 Top button	 Top button	 Top button	 Top button Lower wheel with 4 settings
Shaft	Nickel-plated steel	Stainless steel	Stainless steel	Aluminium
Guarantee	Lifetime			
Height of the mills (cm)	7 - 10 - 14 - 18 - 21 25 - 30 - 40 - 70	7 - 10 - 14 - 18 - 21 25 - 30 - 40	10	7 - 10 - 14 - 18 - 21 - 25 7 - 11 - 14 - 18



COLLECTION B BOIS

B BOIS mills made of beechwood with a beeswax protective finishing.

'B Bois' products are exclusively sold via physical retailers.



Spice mills 'B BOIS' BOOGIE 7 cm



Code	Designation	Øcm	Hcm	Kg
	PEPPER MILL			
P292.071111	Steel mechanism	7	9	0,15
	SALT MILL			
S392.071111	St/steel mechanism	7	9	0,15
	SPICE MILL			
C092.071111	Ceramic mechanism	7	9	0,14

Steel pepper mechanism and stainless steel salt mechanism.
Lifetime warranty for steel mechanism.
Ceramic mechanism suitable for various spices.
Certified "ORIGINE FRANCE GARANTIE".

Spice mills 'B BOIS' RUMBA 14 cm



Code	Designation	Øcm	Hcm	Kg
	PEPPER MILL			
P230.141111	Steel mechanism	4,5	14	0,15
	SALT MILL			
S330.141111	St/steel mechanism	4,5	14	15
	SPICE MILL			
C030.141111	Ceramic mechanism	4,5	14	0,15

Steel pepper mechanism and stainless steel salt mechanism. Certified "ORIGINE FRANCE GARANTIE".
Lifetime warranty for steel mechanism.
Ceramic mechanism suitable for various spices.

Spice mills 'B BOIS' RUMBA 20 cm



Code	Designation	Øcm	Hcm	Kg
	PEPPER MILL			
P230.201111	Steel mechanism	6,4	21	0,33
	SALT MILL			
S330.201111	St/steel mechanism	6,4	21	0,33
	SPICE MILL			
C030.201111	Ceramic mechanism	6,4	21	0,33

Steel pepper mechanism and stainless steel salt mechanism.
Lifetime warranty for steel mechanism.
Ceramic mechanism suitable for various spices.
Certified "ORIGINE FRANCE GARANTIE".



Collection
Java



BY Cert. 6034461



JAVA model is the traditional mill: the wood comes in 4 natural and classical colours according to the models:

light wood, dark wood, matte white and matte black.

- Available in pepper mill, salt mill and spices mill from 14 to 25 cm.
- Available in pepper and salt mills from 14 to 40 cm.
- The model 70 cm exists only for pepper with a steel mechanism.

Certified ORIGINE FRANCE GARANTIE.

Mill JAVA 14 cm



Code	Designation	Hcm	Kg
	PEPPER MILL		
	STEEL MECHANISM		
P245.140101	Natural	14	0,13
P245.140202	Dark	14	0,13
P245.140303	Matte white	14	0,13
P245.140404	Matte black	14	0,13
	SALT MILL		
	STEEL MECHANISM		
S345.140101	Natural	14	0,12
S345.140202	Dark	14	0,12
S345.140303	Matte white	14	0,12
S345.140404	Matte black	14	0,12
	SPICE MILL		
	CERAMIC MECHANISM		
C045.140101	Natural	14	0,13
C045.140202	Dark	14	0,13
C045.140303	Matte white	14	0,13
C045.140404	Matte black	14	0,13

Classical wooden mill.
 Certified "ORIGINE FRANCE GARANTIE".
 Steel pepper mechanism and stainless steel salt mechanism.
 Lifetime warranty.
 Ceramic mechanism suitable for various spices.



Coarse grind pepper mill JAVA STEAK



Code	Designation	Hcm	Kg
M245.140404	Matte black	14	0,13

Special steel mechanism for pepper mill cracked : larger space between the steel teeth to obtain cracked ground pepper
 Certified ORIGINE FRANCE GARANTIE.

Lacquered mill JAVA 14 cm



Code	Designation	Hcm	Kg
PEPPER MILL			
STEEL MECHANISM			
P245.143131	White	14	0,13
P245.143232	Red	14	0,13
P245.143333	Black	14	0,13
P245.143434	Taupe	14	0,13
P245.143636	Curry	14	0,13
SALT MILL			
STEEL MECHANISM			
S345.143131	White	14	0,12
S345.143232	Red	14	0,12
S345.143333	Black	14	0,12
S345.143434	Taupe	14	0,12
S345.143636	Curry	14	0,12
SPICE MILL			
CERAMIC MECHANISM			
C045.143131	White	14	0,13
C045.143232	Red	14	0,13
C045.143333	Black	14	0,13
C045.143434	Taupe	14	0,13
C045.143636	Curry	14	0,13

Classical wooden mill.
 Certified "ORIGINE FRANCE GARANTIE".
 Steel pepper mechanism and stainless steel salt mechanism.
 Lifetime warranty.
 Ceramic mechanism suitable for various spices.

This range of classical mills is made of beech wood. The wood is lacquered : one coat of white lacquer then three coats of the color. The glossy lacquered finish and the vitamin shades bring a colourful touch and brighten up the kitchen and table.

Mill JAVA 18 cm



Code	Designation	Hcm	Kg
PEPPER MILL			
STEEL MECHANISM			
P246.180101	Naturel	18	0,2
P246.180202	Dark	18	0,2
P246.180303	Matte white	18	0,2
P246.180404	Matte black	18	0,2
SALT MILL			
STEEL MECHANISM			
S346.180101	Natural	18	0,2
S346.180202	Dark	18	0,2
S346.180303	Matte white	18	0,2
S346.180404	Matte black	18	0,2
SPICE MILL			
CERAMIC MECHANISM			
C046.180101	Natural	18	0,2
C046.180202	Dark	18	0,2
C046.180303	Matte white	18	0,2
C046.180404	Matte black	18	0,2

Classical wooden mill.
 Certified "ORIGINE FRANCE GARANTIE".
 Steel pepper mechanism and stainless steel salt mechanism.
 Lifetime warranty.
 Ceramic mechanism suitable for various spices.

Mill JAVA 21 cm



Code	Designation	Hcm	Kg
	PEPPER MILL		
	STEEL MECHANISM		
P247.210101	Natural	21	0,24
P247.210202	Dark	21	0,24
P247.210303	Matte white	21	0,24
P247.210404	Matte black	21	0,24
	SALT MILL		
	STEEL MECHANISM		
S347.210101	Natural	21	0,22
S347.210202	Dark	21	0,22
S347.210303	Matte white	21	0,22
S347.210404	Matte black	21	0,22
	SPICE MILL		
	CERAMIC MECHANISM		
C047.210101	Natural	21	0,24
C047.210202	Dark	21	0,24
C047.210303	Matte white	21	0,24
C047.210404	Matte black	21	0,24

Classical wooden mill.
 Certified "ORIGINE FRANCE GARANTIE".
 Steel pepper mechanism and stainless steel salt mechanism.
 Lifetime warranty.
 Ceramic mechanism suitable for various spices.

Mill JAVA 25 cm



Code	Designation	Hcm	Kg
	PEPPER MILL		
	STEEL MECHANISM		
P249.250101	Natural	25	0,3
P249.250202	Dark	25	0,3
P249.250303	Matte white	25	0,3
P249.250404	Matte black	25	0,29
	SALT MILL		
	STEEL MECHANISM		
S349.250101	Natural	25	0,27
S349.250202	Dark	25	0,27
S349.250303	Matte white	25	0,27
S349.250404	Matte black	25	0,3
	SPICE MILL		
	CERAMIC MECHANISM		
C049.250101	Natural	25	0,3
C049.250202	Dark	25	0,3
C049.250303	Matte white	25	0,3
C049.250404	Matte black	25	0,3

Classical wooden mill.
 Certified "ORIGINE FRANCE GARANTIE".
 Steel pepper mechanism and stainless steel salt mechanism.
 Lifetime warranty.
 Ceramic mechanism suitable for various spices.

Pepper/Salt mill JAVA 30 cm, steel mechanisms



Code	Designation	Hcm	Kg
	PEPPER MILL		
P253.300101	Natural	30	0,56
P253.300202	Dark	30	0,56
P253.300303	Matte white	30	0,56
P253.300404	Matte black	30	0,56
	SALT MILL		
S353.300101	Natural	30	0,56
S353.300202	Dark	30	0,56
S353.300303	Matte white	30	0,56
S353.300404	Matte black	30	0,56

Classical wooden mill. Lifetime warranty.
 Certified "ORIGINE FRANCE GARANTIE".
 Steel pepper mechanism and stainless steel salt mechanism.

Pepper/Salt mill JAVA 40 cm, steel mechanisms



Code	Designation	Hcm	Kg
PEPPER MILL			
P251.400101	Natural	40	0,93
P251.400202	Dark	40	0,93
SALT MILL			
S351.400101	Natural	40	0,93
S351.400202	Dark	40	0,89

Classical wooden mill.
Steel pepper mechanism and stainless steel salt mechanism.
Lifetime warranty.
Certified "ORIGINE FRANCE GARANTIE".

Pepper mill JAVA 70 cm



Code	Designation	Hcm	Kg
P256.700101	Natural	70	2
P256.700202	Dark	70	2

Classical wooden mill.
Steel pepper mechanism and stainless steel salt mechanism.
Lifetime warranty.
Certified "ORIGINE FRANCE GARANTIE".



Collection Rumba



BVCert. 6054661



Mill RUMBA 14 cm



Code	Designation	Hcm	Kg
	PEPPER MILL		
	STEEL MECHANISM		
P230.140101	Natural	14	0,14
P230.140202	Dark	14	0,14
P230.140303	Matte white	14	0,14
P230.140404	Matte black	14	0,14
	SALT MILL		
	STEEL MECHANISM		
S330.140101	Natural	14	0,14
S330.140202	Dark	14	0,14
S330.140303	Matte white	14	0,14
S330.140404	Black	14	0,14
	SPICE MILL		
	CERAMIC MECHANISM		
C030.140101	Natural	14	0,15
C030.140202	Dark	14	0,15
C030.140303	White matte	14	0,15
C030.140404	Black matte	14	0,15

A mill with pleasant and well-rounded curves. It offers a good grip, is a convenient size and is very handy in the kitchen and on the table.

Classical wooden mill.
Certified "ORIGINE FRANCE GARANTIE".
Steel pepper mechanism and stainless steel salt mechanism.
Lifetime warranty.

Ceramic mechanism suitable for various spices.

Mill RUMBA 18 cm

new
2021



Code	Designation	Hcm
	PEPPER MILL	
	STEEL MECHANISM	
P230.180101	Natural	18
P230.180202	Dark	18
P230.180303	White matte	18
P230.180404	Black matte	18
	SALT MILL	
	STEEL MECHANISM	
S330.180101	Natural	18
S330.180202	Dark	18
S330.180303	White matte	18
S330.180404	Black matte	18
	SPICE MILL	
	CERAMIC MECHANISM	
C030.180101	Natural	18
C030.180202	Dark	18
C030.180303	White matte	18
C030.180404	Black matte	18

A mill with pleasant and well-rounded curves. It offers a good grip, is a convenient size and is very handy in the kitchen and on the table.

Steel pepper mechanism and stainless steel salt mechanism.
Lifetime warranty.

Ceramic mechanism suitable for various spices.

Certified "ORIGINE FRANCE GARANTIE".



Mill RUMBA 20 cm



Code	Designation	Hcm	Kg
PEPPER MILL			
STEEL MECHANISM			
P230.200101	Natural	20	0,34
P230.200202	Dark	20	0,34
SALT MILL			
STEEL MECHANISM			
S330.200101	Natural	20	0,34
S330.200202	Dark	20	0,34
SPICE MILL			
CERAMIC MECHANISM			
C030.200101	Natural	20	0,35
C030.200202	Dark	20	0,35

A mill with pleasant and well-rounded curves. It offers a good grip, is a convenient size and is very handy in the kitchen and on the table.

Ceramic mechanism suitable for various spices.
Certified "ORIGINE FRANCE GARANTIE".

Steel pepper mechanism and stainless steel salt mechanism. Lifetime warranty.

Pepper/Salt lacquered mill RUMBA 20 cm



Code	Designation	Hcm	Kg
PEPPER MILL			
STEEL MECHANISM			
P230.203131	White	20	0,34
P230.203232	Red	20	0,34
P230.203333	Black	20	0,34
P230.203434	Taupe	20	0,34
P230.203636	Curry	20	0,34
SALT MILL			
STEEL MECHANISM			
S330.203131	White	20	0,32
S330.203232	Red	20	0,32
S330.203333	Black	20	0,32
S330.203434	Taupe	20	0,32
S330.203636	Curry	20	0,32
SPICE MILL			
CERAMIC MECHANISM			
C030.203131	White	20	0,35
C030.203232	Red	20	0,35
C030.203333	Black	20	0,35
C030.203434	Taupe	20	0,35
C030.203636	Curry	20	0,35

Classical wooden mill.
Certified "ORIGINE FRANCE GARANTIE".
Steel pepper mechanism and stainless steel salt mechanism.
Lifetime warranty.
Ceramic mechanism suitable for various spices.

This range of classical mills is made of beech wood. The wood is lacquered : one coat of white lacquer then three coats of the color. The glossy lacquered finish and the vitamin shades bring a colourful touch and brighten up the kitchen and table.

Collection Paso



Mill PASO 10 cm



Code	Designation	Hcm	Kg
	PEPPER MILL		
	STEEL MECHANISM		
P240.100101	Natural	10	0,11
P240.100202	Dark	10	0,11
P240.100303	Matte white	10	0,11
P240.100404	Matte black	10	0,11
	SALT MILL		
	STEEL MECHANISM		
S340.100101	Natural	10	0,09
S340.100202	Dark	10	0,09
S340.100303	Matte white	10	0,09
S340.100404	Matte black	10	0,09
	SPICE MILL		
	CERAMIC MECHANISM		
C040.100101	Natural	10	0,11
C040.100202	Dark	10	0,11
C040.100303	Matte white	10	0,11
C040.100404	Matte black	10	0,11

The mini traditional ideal table model. Indispensable and always fashionable.

Classical wooden mill.
 Certified "ORIGINE FRANCE GARANTIE".
 Steel pepper mechanism and stainless steel salt mechanism.
 Lifetime warranty.

Ceramic mechanism suitable for various spices.

Salt shaker PASO 10 cm



Code	Designation	Hcm	Kg
M340.100101	Natural	8,8	0,05
M340.100202	Dark	8,8	0,05

The mini traditional ideal table model. Indispensable and always fashionable.



Collection Manivelle



Wooden spice mills BOOGIE 7 cm



Code	Designation	Øcm	Hcm	Kg
PEPPER MILL				
Steel mechanism				
P292.070101	Natural	9	7	0,15
P292.070202	Dark	9	7	0,15
SALT MILL				
Stainless steel mechanism				
S392.070101	Natural	9	7	0,15
S392.070202	Dark	9	7	0,15
SPICE MILL				
Ceramic mechanism				
C092.070101	Natural	9	7	0,14
C092.070202	Dark	9	7	0,14

Steel pepper mechanism and stainless steel salt mechanism.
 Lifetime warranty for steel mechanism.
 Ceramic mechanism suitable for various spices.
 Certified "ORIGINE FRANCE GARANTIE".

Nutmeg mill SOKO with crank st/steel handle

Code	Designation	Hcm	Kg
M516.100101	Natural	10	0,13
M516.100202	Dark	10	0,13



The nutmeg, a specialty MARLUX: this original mill has a mechanism in steel unpublished. The nutmeg is stuck on a spring stem and three large teeth hold it on the sharpened plate. Nutmeg is then easily grated by turning handle.
 Certified ORIGINE FRANCE GARANTIE.

Collection Exclusive

Pepper/Salt mill POGO, steel mechanisms



Code	Designation	Hcm	Kg
P222.110606	Pepper mill	11	0,11
S322.110606	Salt mill	11	0,09

A pleasant curve and a matt black finish give simplicity and elegance to this little table mill. Steel pepper mechanism and stainless steel salt mechanism. Lifetime warranty. Certified "ORIGINE FRANCE GARANTIE".

Pepper/Salt mill VALSE, steel mechanisms



Code	Designation	Hcm	Kg
	PEPPER MILL		
P224.110671	Matte black	11	0,18
	SALT MILL		
S324.110671	Matte black	11	0,16

The mill of the large tables with its wooden body with pleasant curves and its lid in metallic silver polished brightly. Steel pepper mechanism and stainless steel salt mechanism. Lifetime warranty.

Pepper/Salt mill JOTA, steel mechanisms



Code	Designation	Hcm	Kg
	PEPPER MILL		
P223.120101	Natural	12	0,24
P223.120606	Ebony	12	0,24
	SALT MILL		
S323.120101	Natural	12	0,21
S323.120606	Ebony	12	0,21

A cylindrical mill with a sleek design, with its grooved aluminum ring and elegant button inlaid in the lid. For the pepper model, the milling adjustment is done from the bottom with a button provided in the mechanism. Steel pepper mechanism and stainless steel salt mechanism. Lifetime warranty. Certified "ORIGINE FRANCE GARANTIE".

Pepper/Salt mill SPRINGAR, steel mechanisms



Code	Designation	Hcm	Kg
	PEPPER MILL		
P227.130670	Ebony	13	0,12
	While stocks last		
	SALT MILL		
S327.130670	Ebony	13	0,16
	While stocks last		

A table model with an industrial style design, a modern combination of stainless steel and wood. Steel pepper mechanism and stainless steel salt mechanism. Lifetime warranty.



Collection Hip Hop

Spices mill HIP HOP 11 cm, ceramic mechanism



Code	Designation	Hcm	Kg
	Delivered empty		
C086.118301	Natural	11	0,09
C086.118302	Dark	11	0,09

Ceramic mechanism suitable for various spices. This mini table mill with its translucent acrylic shape gives a light impression to the table.

Mill delivered empty without spice.

Spices lacquered mill HIP HOP 11 cm, ceramic mechanism



Code	Designation	Kg
	Delivered empty	
C086.118331	White	0,09
C086.118332	Red	0,09
C086.118333	Black	0,09
C086.118334	Taupe	0,09
C086.118336	Curry	0,09

Ceramic mechanism suitable for various spices. This mini table mill with its translucent acrylic shape gives a light impression to the table and its range of coloured lids adapts to all atmospheres.

Spices mill HIP HOP 11 cm, ceramic mechanism



Code	Designation	Hcm	Kg
	Delivered empty		
C086.118383		11	0,09

Ceramic mechanism suitable for various spices. 4 grinding settings with the mill base.

Collection Transparence

Spices mill BOOGIE with crank plastic handle



Code	Designation	Lcm	Wcm	Hcm	Kg
C092.078382	Delivered empty			7	0,18
C192.048382	Box of 4 spices mills C092.078382 Delivered empty	28	7	9	0,77

Ceramic mechanism suitable for various spices. 4 grinding settings with the mill base.

Spices mill TANGO 14 cm



Code	Designation	Hcm	Kg
C087.148383	Delivered empty	14	0,18

Ceramic mechanism suitable for various spices. 4 grinding settings with the mill base.

Spices mill MAMBO 18 cm



Code	Designation	Hcm	Kg
C084.188383	Delivered empty	20	0,23

An original baroque mill for the kitchen or table. It looks modern and light due to its transparency.
Steel pepper mechanism and stainless steel salt mechanism. Steel mechanisms are lifetime warranty.
Ceramic mechanism suitable for various spices. 4 grinding settings with the mill base.



PRECISE CUTTING WITH MANDOLINES AND KNIVES

The first mandoline enjoyed great success, for being an innovative product (item, tool) that was quick, precise, easy-to-use, durable (lasting) and safe. All the following conceived mandolines stuck to these essential production criteria. De Buyer mandolines have the “Origine France Garantie” label.

- 114 -

Mandoline REVOLUTION

Mandoline VANTAGE

Mandoline VIPER

Mandoline ACCESS

Mandoline SWING PLUS

- 124 -

Mini slicer KOMI

Slicer KOBRA

- 126 -









Corer, tomato slicer

- 128 -

Knives & Sharpeners



SLICERS

	THE SLICERS				THE COMPACTS		
Collection	La Mandoline REVOLUTION	Vantage >	VIPER MANDOLINE	La Mandoline ACCESS	Swing PLUS	KOBRA ^{19.3}	Komi
	2012.01	2017.00	2016.00	2014.00	2015.03 / 2015.23 / 2015.43	2011.01 / 2011.21 / 2011.41	2018.00
Type of cuts :							
• Slices	 ✓	✓	✓	✓	✓	✓	✓
• Crinkle cut	 ✓		✓	✓	✓		
• Julienne cuts	 ✓ 2 - 4 and 10 mm « MASTER » version 2 - 3 - 4 - 5 - 7 and 10 mm	✓ 2 - 4 - 7 and 10 mm	✓ 4 - 10 mm	✓ 4 - 10 mm 2 - 7 mm	✓		✓ 2 - 4 mm
• Waffle cuts	 ✓			✓			
• Cubes, losanges	 ✓		✓				
Type of blade		V		Straight		V	35° angle
Thickness from (mm)	0 to 10	1 to 10	1 to 8		0 to 10		
Folding rear foot	✓	✓	✓	✓	✓		
Gravity guide + pusher	 ✓	✓	✓	✓	✓		
Extra long pusher	✓	✓					
Colours							
PCB (packaging unit)	1	1	1	1	1	1	1



SLICING KIT

GRAVITY

A GUIDE FOR CUTTING
 LONG VEGETABLES - SMALL VEGETABLES
QUICKLY, EFFORTLESS
WASTE FREE AND SAFELY

e x a m p l e s



LONG VEGETABLES



cucumber, carrot, zucchini, long radish...

STRAIGHT OR *
 CRINKLED SLICES

SMALL FRUITS & VEGETABLES



cherry tomato, shallot, radish, mushroom...



**fits on the slider of DE
 BUYER 's mandolines**
(not for Kobra slicer)



2015.84 Kit Gravity
 with tube slider and grey insert
(delivered without mandoline)

LA MANDOLINE REVOLUTION



La Mandoline REVOLUTION



Multi-cuts : cubes, losanges, slices, crinkle cuts, Julienne cuts, waffle cuts.
 Thickness from ultrafine slices to one-centimeter.
 Professional: made of foodgrade st/steel and polymer composites. Satin polished st/steel.
 Horizontal double-blade made of high-quality cutlery st/steel. Julienne blades made of heavy duty professional st/steel.
 SECURE with its protective pusher. Easy to handle.
 Integrated dice system

Code	Designation	Lcm	Wcm	Hcm	Kg
2012.01	Complete Mandoline with receptable & pusher with 1 double horizontal blade-straight/serrated and 3 Julienne blades 2-4-10 mm	39,5	19,5	14	1,54
	STAINLESS STEEL PUSHER with rotating control system				



La Mandoline REVOLUTION MASTER with stainless steel pusher

Code	Designation	Lcm	Wcm	Hcm	Kg
2012.41	Complete Mandoline with receptable & pusher	39,5	19,5	14	2,38
	REVOLUTION MASTER version with : STAINLESS STEEL PUSHER with rotating control system - 6 Julienne blades 2-3-4-5-7-10 mm in their removable storage box - EXTRA-LONG PUSHER - Special coated upper plate - Double horizontal blade - lobe edged - Upper foot with cap				



Same features as the standard model. Improved design and optimum efficiency.
Supplied with the st/steel round pusher and with one plastic extra-long pusher for long products.
6 Julienne blades 2-3-4-5-7 and 10 mm in their storage box
The upper foot is reinforced with st/steel 2 caps.
Improved slide with the special « pro-slide » coating on the upper plate.

La Mandoline REVOLUTION : Replacement parts



Code	Designation	Lcm	Wcm	Kg
2012.56	Rotating control system (slider and pusher)			0,62
	Slider + st/steel pusher			
2012.57	St/steel pusher alone			0,5
2012.55	Long pusher + slider			0,24
	Suitable for the standard Mandoline			
2000.97	Small lower foot/stand	12	11,5	0,12
	For REVOLUTION & REVOLUTION MASTER			
2012.98	Upper foot REVOLUTION MASTER			
2000.89	Set of 2 tightening knobs			



Slicing kit GRAVITY

Code	Designation	Øcm	Wcm	Hcm	Kg
2015.84	GRAVITY guide and pusher See page 105	5	10,5	14,5	0,18



A GUIDE FOR CUTTING LONG VEGETABLES & SMALL VEGETABLES QUICKLY, EFFORTLESSLY, WASTE FREE AND SAFELY.
It fits on the slider of DE BUYER 's mandolines

La Mandoline REVOLUTION : Replacement parts

Code	Designation	Lcm	Wcm	Th.mm	Kg
2015.95	Double horizontal blades - with lobed edge	15,5	3,2	0,5	0,03
	JULIENNE blades :				
2012.91	JULIENNE 2 mm - black				0,02
2012.92	JULIENNE 4 mm - red				0,02
2012.93	JULIENNE 10 mm - grey				0,02
2012.94	JULIENNE 3 mm - green				0,02
2012.95	JULIENNE 5 mm - blue				0,02
2012.96	JULIENNE 7 mm - orange				0,02
2012.88	Support for 3 Julienne blades (empty) For Mandoline REVOLUTION standard				0,04
2012.89	Storage box for 7 blades - delivered empty				



LA MANDOLINE VANTAGE



La Mandoline VANTAGE



Code	Designation	Lcm	Wcm	Hcm	Kg
2017.00	Complete Mandoline with slider and pusher - Integrated V-shaped blade - 4 Julienne blades 2-4-7-10 mm - V-shaped blade guard for storage - Storage box for accessories - EXTRA-LONG PUSHER	50	15	20	1,83

V-shaped blade to cut all types of fruit/vegetable even the softest. Total safety thanks to the ergonomic pusher and the slider.
Stainless steel frame : robust and resistant.
Equipped with 4 V-shaped Julienne blades
Minimum space - Folding foot.



La Mandoline VANTAGE - Replacement parts 2017.00



Code	Designation	Kg
2017.91	Julienne 2 mm cut - 41 teeth	0,03
2017.92	Julienne 4 mm cut - 22 teeth	0,03
2017.93	Julienne 7 mm - 14 teeth	0,03
2017.94	Julienne 10 mm - 10 teeth	0,03
2017.89	Plastic storage box (empty)	0,27
2017.59	Pusher	0,13
2017.90	Slider	0,05
2017.86	V-blade guard	0,01

La Mandoline VANTAGE - Extra long pusher



Code	Designation	Lcm	Wcm	Hcm	Kg
2017.55	Extra long pusher and slider	17,2	13	6,8	0,27

It is used in place of the round pusher. It is the perfect tool to obtain very long cutting shapes.



Slicing kit GRAVITY



Code	Designation	Øcm	Wcm	Hcm	Kg
2015.84	GRAVITY guide and pusher See page 105	5	10,5	14,5	0,18

A GUIDE FOR CUTTING LONG VEGETABLES & SMALL VEGETABLES QUICKLY, EFFORTLESSLY, WASTE FREE AND SAFELY.
It fits on the slider of DE BUYER 's mandolines



LA MANDOLINE VIPER



VIPER Mandoline



Code	Designation	Lcm	Wcm	Hcm	Kg
2016.00	Complete Mandoline with receptacle & pusher with horizontale blade & 2 Julienne 4 -10 mm	44	18,5	15	1,36

Frame with integrated V-shaped horizontal blade for accurate and easy cutting of all fruits/vegetable.
 Adjustable slice plate - Thickness from 1 to 8 mm.
 Knob for fast and precise thickness setting.
 Two julienne plates - 4 and 10 mm - and their storage box.
 Large receptacle for vegetables/fruits.

Secure with the ergonomic pusher and slider.
 Equipped with rotation control system to cut dices and diamonds easily.
 Compact with its folding rear foot.



Slicing kit GRAVITY



Code	Designation	Øcm	Wcm	Hcm	Kg
2015.84	GRAVITY guide and pusher See page 105	5	10,5	14,5	0,18

A GUIDE FOR CUTTING LONG VEGETABLES & SMALL VEGETABLES QUICKLY, EFFORTLESSLY, WASTE FREE AND SAFELY.
It fits on the slider of DE BUYER 's mandolines

La Mandoline VIPER: Replacements parts



Code	Designation	Lcm	Wcm	Hcm	Kg
2016.96	Horizontal plate for slices	26	12	0,09	0,18
2016.92	Plate Julienne 4 mm	13,2	9,5	0,12	0,11
2016.94	Plate Julienne 10 mm	14,5	10,8	0,05	0,12

La Mandoline VIPER : Replacement parts



Code	Designation	Lcm	Wcm	Hcm	Kg
2016.59	Ergonomic plastic protective pusher	25,2	12	17,5	0,12
2016.90	Plastic slider	26	12	2,5	0,55



LA MANDOLINE ACCESS



LA MANDOLINE ACCESS Stainless steel



Code	Designation	Lcm	Wcm	Hcm	Kg
2014.00	Complete mandoline with polymer composite pusher	44,5	18	23	1,45
	Delivered with a double horizontal blade blade (straight & serrated) and a double Julienne blade (space 4 and 10 mm)				
	- Easy thickness adjustment				
	- Lobed-edge horizontal blade				
	- Ergonomic pusher				

ROBUST AND PROFESSIONAL : Mandoline made of stainless steel
 COMPACT - Easy to handle - Double-blades system : one single accessory for 2 uses.
 Folding upper foot for storage.
 PRACTICAL : Easy inserting of the blades on the side and easy thickness adjustment mechanism.
 EFFICIENT : Easy and precise cut.
 SAFE : Ergonomic pusher for maximum safety
 Non-skid feet.

MULTICUTS : Includes double horizontal blades (straight and serrated) and Julienne blades (space 4 and 10 mm) to produce many cut styles : Julienne cuts, waffle cut, slice or crinkle cuts.
 Precise thickness adjustment until 10-mm.



Replacement parts for LA MANDOLINE ACCESS



Code	Designation	Lcm	Wcm	Th.mm	Kg
2015.92	Double Julienne blade - 4 and 10 mm				0,26
2015.93	Double Julienne blade - 2 and 7 mm with storage box for both Julienne blades				0,09
2015.95	Double horizontal blades - with lobed edge	15,5	3,2	0,5	0,03
2017.90	Slider				0,05
2014.59	Pusher				

Easy and precise cut thanks to the blades made of high-quality stainless steel. Double-blades system -one single accessory for 2 uses- :

- Straight blade and serrated blade
 - Julienne blade 4/10 mm and Julienne blade 2/7 mm

Slicing kit GRAVITY



Code	Designation	Øcm	Wcm	Hcm	Kg
2015.84	GRAVITY guide and pusher See page 105	5	10,5	14,5	0,18

A GUIDE FOR CUTTING LONG VEGETABLES & SMALL VEGETABLES QUICKLY, EFFORTLESSLY, WASTE FREE AND SAFELY.

It fits on the slider of DE BUYER's mandolines

LA MANDOLINE SWING PLUS



BV Cert. 6054661



La Mandoline SWING PLUS



ROBUST AND PROFESSIONAL : Mandoline made of stainless steel and polymer composite.
COMPACT - Easy to handle - Double-blades system : one single accessory for 2 uses. Folding upper foot for storage.
PRACTICAL : Easy inserting of the blades on the side and easy thickness adjustment mechanism.
EFFICIENT : Easy and precise cut. **SAFE :** Ergonomic pusher for maximum safety - Non-skid feet
MULTICUTS : Includes double horizontal blades (straight and serrated) and Julienne blades (space 4 and 10 mm) to produce many cut styles : Julienne cuts, waffle cut, slice or crinkle cuts. Precise thickness adjustment until 10-mm.

Code	Designation	Lcm	Wcm	Kg
2015.03	Complete mandoline with polymer composite Delivered with a double horizontal blade blade (straight & serrated) and a double Julienne blade (space 4 and 10 mm) Black colour New model : - Easy thickness adjustment - Lobed-edge horizontal blade - Ergonomic pusher	40	20	1,19
2015.23	Green colour	40	20	1,19
2015.43	Red colour	40	20	1,19

Replacement parts for SWING PLUS : pusher and slider



Code	Designation	Kg
2015.59	Plastic pusher	0,22
2015.90	Slider for 2015.59	0,6

Large capacity of the receptacle: more products are cut at a single time. Ergonomic pusher for maximum safety

Accessories for LA MANDOLINE SWING PLUS



Code	Designation	Øcm	Lcm	Wcm	Hcm	Th.mm	Kg
2015.92	Double Julienne blade - 4 and 10 mm						0,26
2015.93	Double Julienne blade - 2 and 7 mm with storage box for both Julienne blades						0,09
2015.95	Double horizontal blades - with lobed edge		15,5	3,2		0,5	0,03
2015.84	GRAVITY guide and pusher See page 105	5		10,5	14,5		0,18

Easy and precise cut thanks to the blades made of high-quality stainless steel. Double-blades system -one single accessory for 2 uses- : - Straight blade and serrated blade - Julienne blade 4/10 mm and Julienne blade 2/7 mm

LA MANDOLINE KOBRA



KOBRA V AXIS

"Click Express" system

adjusts the thickness setting quickly, safely and efficiently

Cuts slices from extra-fine up to 5mm thick

KOBRA V AXIS : Professional fruit and vegetable slicer with pusher

Code	Designation	Lcm	Wcm	Hcm	Kg
2011.01	Complete with pusher - Black	36,5	12,2	8	0,66
2011.41	Complete with pusher - Red	36,5	12,2	8	0,66
SPARE PARTS :					
2011.55	Pusher alone				
2011.90	Kit spare parts Kobra				



- V-shaped blade: the blade penetrates the product easily.
- Optimised cutting angle at 19,3°. Cuts easily and perfectly all fruits and vegetables, even the softest ones (tomatoes, pears, etc.).
- Micro-serration of the blade enables the thinnest cut of fruit/vegetable with skin and preserves their flesh composition.
- PRACTICAL & EASY: easy to adjust the height of the cut: the thumb wheel integrated at the end of the handle allows the adjustment of the thickness up to 5 mm. - St/steel ramp
- COMPACT: the pusher clips on for easy storage.
- SAFE Protective pusher. Silicone moulded anti-sliding ergonomic handle. Anti-skid feet.





Mini vegetable slicer KOMI



Code	Designation	Lcm	Wcm	Hcm	Kg
2018.00	Complete vegetable cutter with food guard and 2 Julienne blades 2/4 mm	27	11,2	3,3	0,38
SPARE PARTS :					
2018.90	Pusher				
2018.92	Julienne 2 mm				
2018.93	Julienne 4 mm				
2018.95	Blade				

Accurate and efficient: sharp blade with its 35°-angle.
 Multicut: slices & Julienne 2 mm/4 mm (0.08/0.15 in.).
 Quick and easy thickness adjustment.
 Graduated from 0 up to 5 mm.
 Equipped with an ergonomic protective food guard made of transparent plastic.
 Compact storage: integrated Julienne blades storage box & food guard.





Stainless steel tomato slicer, 5,5 mm thickness



For 10 slices - 5,5 mm thick.

Serrated blades special for tomatoes. The horizontal cutting action avoids juice loss.

The tomato slicer lets you slice ripe tomatoes but also citrus fruits (lemons, oranges, kiwis,...). Suckers on the feet hold the slicer firmly in place on the worktop during use.

Safe: cover guards prevent anyone touching the blades. 2 ergonomic handles.

Made of all stainless steel: easy cleaning.

Code	Designation	Lcm	Wcm	Hcm	Kg
2005.00	Tomato slicer	42,5	20	18	5,5
2005.10	Set of replacement blades	24,5		7	0,14

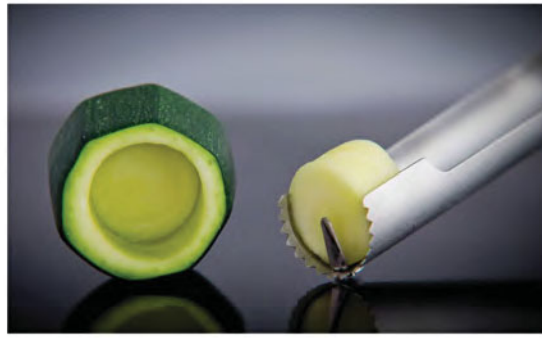

Manual corer for fruits/vegetables - ø12 mm - Orange

Manual corer for fruits/vegetables - ø20mm - Green

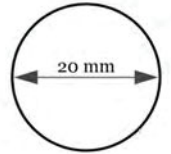

Code	Designation	Øcm	Lcm	Kg
2612.01	L. tube 90 mm - Graduated	2,5	19,7	0,04

Manual extractor that cores and tops and tails fruits/vegetables cleanly in a trice. Patented system. Universal: suitable for various fruits/vegetables.

Multifunctions: removing stalk / Hollowing out / Stuffing. Overmoulded with TPE polypropylene ergonomic anti-slip handle

with hole to hang; Stainless steel blade and graduated tube.

Code	Designation	Øcm	Lcm	Kg
2612.02	L. tube 112 mm - Graduated	3	24,6	0,08

Manual universal corer for fruits / vegetables - ø30 mm - Red

Code	Designation	Lcm	Kg
2612.03	L. tube 112 mm - Graduated	25	0,1

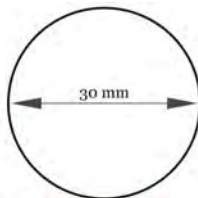

Manual extractor that cores and tops and tails fruits/vegetables cleanly in a trice. Patented system. Universal : suitable for various fruits/vegetables. Multifunctions: removing stalk / Hollowing out / Stuffing.

Overmoulded with TPE polypropylene ergonomic anti-slip handle with hole to hang - Stainless steel blade and graduated tube.

FRENCH-STYLE KNIVES

De Buyer has carefully analysed French and Japanese knife design. The findings were clear: Japanese knives have a perfect cutting edge while French knives are outstandingly solid. De Buyer chose to differ obviously by combining these two key elements when creating its two knife ranges.



FK1
FIBRE KARBON 1

De Buyer created the Fibre Karbon 1 collection for the most demanding of professional chefs. The high tech handle, compression-moulded in France with multiple layers of carbon fibre, is light and extremely strong, making it perfectly balanced and pleasant to hold. Blades are very strong in the European tradition, and very sharp in the Japanese tradition – the perfect blend of both cutlery and culinary worlds.
Blade made of hard edge 56+/-2 HRC stainless steel German X50CrMoV15 - One-piece

Japanese knife with single-bevel blade- L. 26 cm



Code	Designation	Lcm	Wcm	Hcm	Kg
4270.26		41,5	1,85	6	0,46

Resulting from the fusion of a French Chef's knife to prepare meat and vegetables, and a Japanese single bevel sashimi knife for the finest of slicing.

Chef's knife FIBRE KARBON 1 - L. 22 cm



Code	Designation	Lcm	Wcm	Hcm	Kg
4271.22		36,5	1,86	6,1	0,35

Traditional strong French chef's blade for all regular heavy cutting work.

Japanese Chef's knife FIBRE KARBON 1 - L. 23 cm



Code	Designation	Lcm	Wcm	Hcm	Kg
4271.24		35,5	1,88	6,8	0,4

Like a traditional French Chef's blade, but more advanced : thinner and sharper cutting edge and scallops for less cutting effort, but strong for the toughest chef work.

Utility knife FIBRE KARBON 1 - L. 18 cm



Code	Designation	Lcm	Wcm	Hcm	Kg
4275.18		30	16,3	3,14	0,17

Between the small office knife and the chef knife, it is ideal for many small cutting tasks.

Paring knife FIBRE KARBON 1 - L.11 cm



Code	Designation	Lcm	Wcm	Hcm	Kg
4272.11		22,9	1,63	2	0,14

A high performance small utility knife or steak knife.

FK2

The knives FK2 are designed to be the ultimate blend of toughness, sharpness, functionality and value for real working chefs and serious gourmet cooks. In addition to the traditional blades expected, the FK2 range has many innovative blade shapes .



- **HARDNESS** : German X50CrMoV15 stainless steel alloy hardened and tempered to HRC56. Hard for edge retention and tough for edge durability
- **REBALANCE SYSTEM** : find your ideal balance with the innovative adjustable counterweight
- **UNIQUE BLADE GEOMETRY** : a fine grind between the thick German blades and light Japanese blades to bring strength and sharpness together
- **ROBUST HANDLE** : CARBON FIBRE COMPOSITE. Dynamic and ergonomic handle shape with texture grips strongly to resist hand slip
- **SOLID AND STRONG** : thick tang for long term durability. Solid one-piece bolster
- **Made in France**



French Chef 's knife



This knife is the traditional French chef's knife for all heavy cutting work (vegetables, meat and fish).

Code	Designation	Lcm	Wcm	Hcm	Kg
4281.21	L. 21 cm While stocks last	36	2,2	6	0,28

Santoku knife L. 17 cm



Code	Designation	Lcm	Wcm	Hcm	Kg
4281.17		32,4	2,2	5,4	0,26

Good broad range of uses: slicing, chopping of meat and vegetables.

Asian Chef's knife



Code	Designation	Lcm	Wcm	Hcm	Kg
4280.15	L. 15 cm	28,6	4,9	2	0,16
4280.17	L. 17 cm	30	5,5	1,8	0,18

This 15cm Asian Chef's knife is very light and sharp and easy to maneuver for light quick cutting tasks in busy kitchens. It is also designed to be ideal for young cooks or for small hands.

Paring knife L. 9 cm



Code	Designation	Lcm	Wcm	Hcm	Kg
4282.09		21,7	2	2,3	0,12

Used by chefs for peeling, turning, and other small hand-held jobs.

Utility knife L. 14 cm



Code	Designation	Lcm	Wcm	Hcm	Kg
4285.14		26,7	2	3	0,14

Small chopping/slicing knife for many light meat/vegetable jobs for chefs and home cooks.

Precision carving knife with short and flexible Santoku blade L.16 cm



Code	Designation	Lcm	Wcm	Kg
4287.16		27,5	2	0,14

Ideally suited for carving thin slices from small pieces of meat and fish with perfect precision.

Salmon and ham knife Santoku 30 cm



Code	Designation	Lcm	Wcm	Th.mm
4287.30		42,5	2	2,6

Ultra flexible scalloped blade for cutting thin slices of bacon, ham or salmon.



Filet knife



Code	Designation	Lcm	Wcm	Hcm	Kg
4283.16	L. 16 cm While stocks last	30,9	2,2	2,3	0,2
4283.18	L. 18 cm Perfect for Filet of Sole While stocks last	28,5			0,14

This knife is perfect to for slicing fillets from fish and chicken. The blade is relatively long, narrow and flexible, for less slicing resistance.

Boning knife L.13 cm

Code	Designation	Lcm	Wcm	Hcm	Kg
4284.13	While stocks last	27,8	2,2	1,8	0,19



Specialty boning knife for chefs.

Carving Knife



Code	Designation	Lcm	Wcm	Hcm	Kg
4285.21	L. 21 cm While stocks last	35,8	2	4	0,26
4285.26	L. 26 cm While stocks last	40,6	2,2	4	0,28

Traditional western meat slicing blade (with sword tip). This knife is perfect for slicing large roasts, hams, etc. The blade is designed to offer the least resistance when slicing meat ,

allowing long cuts to be performed easily. It also slices cakes with ease.

Bread knife



Code	Designation	Lcm	Wcm	Hcm	Kg
4286.26	L. 26 cm While stocks last	40,5	2,2	3,9	0,28

Bread knife with rounded tooth serration for longer blade life and smoother cutting. This type of serration also makes it a good 'bulk' or rough meat slicer.



High Tech Pro Knife sharpener DIAMOND CAMS, 2 levels



DIAMOND CAMS™
PRO KNIFE SHARPENER

Code	Designation	Lcm	Wcm	Hcm	Kg
	SHARPENS AND HONES ANY KNIFE BRAND QUICKLY AND ACCURATELY				
4290.01	Professional 15°-20° fine convex	10,5	20	7,5	0,2

Resulting from many years of mechanical engineering R&D, the de Buyer 'DIAMOND CAMS' sharpener generates perfectly shaped and fine slightly convex edge bevels every time. Simply swipe any blade down and back through the highly engineered diamond-coated solid steel cams until the edge is razor sharp. Two stages in one: swipe light and shallow for everyday honing, and hard and deep

for edge resharpening, including complete regrinding of old blades. More accurate than manual steel and stone methods because human error is eliminated with the accurate angle control of the sharpening/honing cams. Patents pending.

Blade Sharpener TRIUM, 3 levels



TRIUM™

Code	Designation	Lcm	Wcm	Hcm	Kg
4290.02		12	6,7	5,7	0,33

The TRIUM Sharpener was developed to produce very sharp professional cutting edges on any brand of knife. The patent pending Diamond Cams control the edge angle very accurately as you swipe the blade down and back between the cams, for a highly refined cutting edge shape with a perfect hone ever time.

Professional steel QUINTUM, 5 levels



QUINTUM™

Code	Designation	Lcm	Wcm	Kg
4291.00		45	3	0,32

The 5-stage professional sharpening and honing centre : the QUINTUM produces sharper knives in less time than traditional methods for better results for chefs and butchers, and easy pro results for home cooks : Diamond Cams in handle for full regrind of worn edges + 4 more stages of

finer sharpening on steel shaft, 2 diamond and 2 hard chrome surfaces.

Polyethylene cutting board



Code	Designation	Lcm	Wcm	Hcm	Kg
	Sharp angles				
4920.60N	White	60	40	2	3,9

The polythene cutting board is more hygienic than a wooden board because of the non-porous material.

Stainless steel cutting board rack for 6 boards



Code	Designation	Lcm	Wcm	Hcm	Kg
4140.00N	Spacement 3 cm	27	31,5	27,5	1,1

This practical rack lets you stack different cutting boards away or

leave them to drain after washing. It lets you easily identify and take the right board.



ESSENTIAL UTENSILS

From bowls to spatulas and whisks, De Buyer utensils are designed to work like natural extensions of your hand. They are ergonomic and comfortable to use. Especially noteworthy are our exclusive De Buyer piston funnels and “Le Tube” pressure pastry syringe, all with the “Origine France Garantie” label.

- 136 -

St/steel utensils for preparation
Automatic dispensers
LE TUBE

- 146 -

Small utensils, whisks
& spatulas

- 159 -

Seafood utensils

- 161 -

Pizza accessories

- 163 -

Thermometers



Flat bottom pastry bowl, round opened edge



Code	Designation	Øcm	Hcm	Liters.	Th.mm	Kg
3250.16		16	9	1	0,8	0,19
3250.20		20	10	2	0,8	0,24
3250.24		24	11,2	3,5	1	0,4
3250.28		28	12,5	5,5	1	0,56
3250.32		32	14	8	1	0,74
3250.36		36	15	11,5	1,2	1,1
3250.40		40	17,5	16	1,2	1,42
3250.44	Disponibile fino ad esaurimento scorte	44	19	20,5	1,2	1,63

Bowls for professional use, as much for their capacity as for the quality and thickness of the stainless steel used. They have an open rolled rim: rolled for handling without injury and open for

improved hygiene. Polished finish.

Hemispherical bowl, round opened edge



Code	Designation	Øcm	Liters.	Th.mm	Kg
3372.16N		16	1	0,7	0,23
3372.20		20	2,1	0,7	0,35
3372.24		24	3,6	0,7	0,49
3372.30		30	7	0,7	0,7
3371.35		35	11,2	0,8	1,01
3371.40		40	16,8	0,8	1,35
Round stand for hemispherical bowl					
3379.00	For ø 20 - 24 cm			1	0,11
3379.01	For ø 30-35-40 cm			1	0,18

This stainless steel bowl, with its splayed skirt, owes its name to its round base. Its half-spherical form allows for the preparation to be well aerated during mixing, which is performed with downward movements. Inseparable from its whisk, the cul-de-poule is the ideal utensil for easily and rapidly making floating islands or emulsions.

- Professional stainless steel - Robust and undistortable
- Gloss polished outside & satin polished inside
- Hemispherical for a good ventilation of the preparation during mixing
- Open rim for perfect hygiene
- Rolled rim for handling without injury

Hemispherical pastry bowl, stainless steel and silicone



Code	Designation	Øcm	Liters.	Th.mm	Kg
3373.16		16	1	0,7	0,24
3373.20		20	2,1	0,7	0,37
3373.24		24	3,6	0,7	0,5
3373.30		30	7	0,7	0,73

De Buyer has developed a stainless steel, and never slips during use. The interior graduations are also practical. The bowl is stable



Hemispherical pastry bowl made of foodgrade polypropylene



Code	Designation	Øcm	Hcm	Liters.	Kg
4530.17		17,5	8	1	0,08
4530.23		23	10,5	2,5	0,16
4530.27		27,5	12	4,5	0,2
4530.32		32	14,5	6	0,26
4530.36		36	16	9	0,3
4530.40		40	18	13	0,4
4530.90	Set of 6 bowls from 1 L. to 13 L.				1,4

Dishes



Code	Designation	Lcm	Wcm	Hcm	Liters.	Th.mm	Kg	PU
3283.27		27	22	4	1,9	1	0,63	10
3283.30		30	25	4,3	2,6	1	0,79	10
3280.35		35	27	4,6	3,6	1	0,97	10
3280.40		42	32	5	4,9	1	1,24	5
3280.45		45	34	5	6,5	1,2	1,86	5

These stainless steel dishes are particularly resistant to knocks that happen during the course of handling. Besides this, they comply with professional dimensions.

Stainless steel conical colander with base and 2 handles



Code	Designation	Øcm	Lcm	Hcm	Th.mm	Kg
3930.24		23,5	32	11,5	1	0,54
3930.32		29,4	39,5	14,4	1	0,8
3930.36		33	44,5	15,5	1,2	1,21
3930.40		36,5	49	17	1,2	1,47
3930.44		40	53,4	19	1,2	1,83
3930.48		44,6	58	19,3	1,2	2,14

This colander is made from 1.2mm (18 gauge) stainless steel, making it very robust and knock resistant. High quality.

Stainless steel colander - Professional quality



Code	Designation	Øcm	Lcm	Hcm	Th.mm	Kg
3232.24	Conical, 1 handle (1)	23,5	45	11	1	0,57
3232.28	Conical, 1 handle (1)	27	54	12	1	0,76
3240.24	-2	24	31,5	12	0,8	0,69

Colanders made from food-grade stainless steel. 3 different models are available. The colanders with a handle and a hook can be hitched onto the rim of a pan during straining.

Kitchen Chinese strainer, heavy - Perforation 1,5 mm



Code	Designation	Øcm	Hcm	Th.mm	Kg
3350.10N	(1)	10	7,1	0,4	0,08
3350.14N	(2)	14	10,5	0,4	0,15
3350.18N		18,5	16	0,4	0,31
3350.20N		20	18	0,4	0,38
3350.23N		23	20,5	0,4	0,45
3350.26N		27	23	0,4	0,71
3354.01	Non-slip stainless steel stand	15	6	0,17	

Range of different sizes made from heavy, extra-wear-resistant stainless. There is a hook opposite the handle to fit the conical strainer inside a pan. You can place the conical strainer on the stand of a piston funnel to avoid spilling the contents.



Bakery chinese strainer, micro-perforated 0,8 mm



Code	Designation	Øcm	Hcm	Th.mm	Kg
3351.21	chinese strainer ø 21 cm	21	20,5	1	0,46
3351.23	chinese strainer ø 23 cm	23	22	1	0,56
3354.01	Non-slip stainless steel stand	15	6	0,17	



Looking for all the world like its cousin the conical kitchen strainer, the stainless steel pastrycook's strainer has the added feature of micro perforations, making it as efficient as a muslin strainer but with several advantages: hygiene, toughness, and safety. This

conical strainer is professional-grade and extremely solid. Especially easy cleaning.

Pusher for chinese strainer made of beechwood



Code	Designation	Lcm	Wcm	Kg
3350.90		25,5	5	0,19

Stainless steel frame muslin strainer - Twile mesh 0,4 mm



Code	Designation	Øcm	Lcm	Hcm	Th.mm	Kg
3352.20N		20	44	18	0,6	0,48

Handle thickness : 2 mm
Reinforced with its ø 4mm st/steel wire to protect the mesh

This strainer is fitted with a hook and a tongue enabling it to sit on round bowls. Hole mesh size: 0,4mm. It allows for the very fine filtration of gelatin, coulis or custard. 40 mesh.

Deep stainless steel frame muslin strainer - Twile mesh 0,4 mm



Code	Designation	Øcm	Lcm	Hcm	Kg
3352.22		22	45	23	0,57

Stainless steel sieve with 4 removable meshes

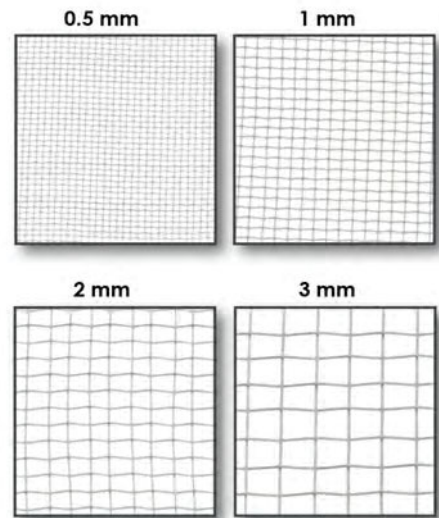

Code	Designation	Øcm	Kg
4605.21	mesh 3 mm/2 mm/1 mm/0,5 mm	20	0,37

- USES :
- Mesh 0.5 mm : flour, icing sugar
 - Mesh 1 mm : almond or hazelnut flour
 - Mesh 2 mm : purées, fish mousse
 - Mesh 3 mm (screen) : Peeling hazelnuts, chopped pralines mixes, marzipan grater

Stainless steel flour sieve with st/steel mesh N° 20 - mesh 0,8 mm



Code	Designation	Øcm	Hcm	Kg
4604.16		16	5,5	0,11
4604.21		21	6	0,19
4604.30		30	7	0,31

Strainer, st. steel



Code	Designation	Øcm	Lcm	Kg
	Mesh thickness 0,27 mm			
3242.10N		10	25,5	0,08
3242.12N		12	32,5	0,11
3242.14N		14	35	0,13
3242.16N		16	37	0,2
3242.18N		18	40	0,22

Perforated stainless steel strainer

Dredger, stainless steel



Code	Designation	Øcm	Hcm	Liters.	Kg
4782.00N	Sugar dredger with metal mesh (1)	7	13	0,5	0,17
4782.01N	Sugar dredger with metal mesh	7	10	0,31	0,14
4783.00N	Sugar dredger - small holes ø1,5 mm (2)	7	13	0,5	0,17
4783.02N	Sugar dredger - small holes ø1,5 mm	7	10	0,31	0,14
4783.01N	Spices dredger - large holes (3) 2,5 mm	7	13	0,5	0,17
4783.03N	Spices dredger - large holes 2,5 mm	7	10	0,31	0,14

The perforated metal sprinkler is ideal for sprinkling with icing sugar. It comes with a bayonet-fitting top.

Stainless steel professional food mill and sieves



Code	Designation	Øcm	Lcm	Hcm	Kg
2004.00N	Professional mill N° 5 without sieve	37	41	38,5	3,1
2004.10N	Sieve for N°5, ø 1 mm				
2004.15N	Sieve for N°5, ø 1,5 mm				
2004.20N	Sieve for N°5, ø 2 mm				
2004.30N	Sieve for N°5, ø 3 mm				
2004.40N	Sieve for N°5, ø 4 mm				
2007.00N	Semi-professional mill N° 3 delivered with 3 sieves 1,5mm - 2,5 mm - 4 mm	31			3

This professional stainless steel food mill lets you prepare puree, stewed fruit, fish soup, vegetable soup, etc. Three models of sieve fit onto it, each with different sized perforations.



Graduated bucket with base



Code	Designation	Øcm	Hcm	Liters.	Th.mm	Kg
3276.12N	Inner ø 29 cm	31	28,5	12	1,5	1,34

Food-grade stainless steel bucket for holding any kind of food or liquid. Internal graduations every litre (except the 5 litre model).

Bucket without base



Code	Designation	Øcm	Hcm	Liters.	Th.mm	Kg
3274.12N	Grad. - inner ø 29 cm	31	27	12	1,5	1,2

food-grade stainless steel bucket for holding any kind of food or liquid. Internal graduations every litre (except the 7 litre model).

Measuring jug with foot, handle and with a spout



Code	Designation	Øcm	Hcm	Liters.	Th.mm	Kg
3565.05N		10	10,5	0,5	0,3	0,14
3565.10N		13,5	14	1	0,3	0,24
3565.15N		14	15	1,5	0,3	0,33
3565.20N		16	18,5	2	0,3	0,41
Small measuring jug with handle without foot						
3565.010N		6,8	4,5	0,1	0,2	0,03
3565.025N		8,5	7	0,25	0,2	0,07

This food-grade stainless steel measuring jug facilitates cooking and lets you measure liquids quickly. Easy to handle with its handle and pouring lip. Can be sterilized.

Scoop, st. steel



Code	Designation	Lcm	Wcm	Hcm	Liters.	Th.mm	Kg
3271.20	Flour scoop, with handle 75 cl	20	12	5,5	0,75	1,5	0,41
3271.24	Flour scoop, with handle 1,4 L	24	15	6,5	1,4	1,5	0,53

These stainless steel scoops ensure perfect hygiene. The stainless tube handle is welded.

Flour scoop , polypropylene



Code	Designation	Lcm	Liters.	Kg
4370.02N		26	0,25	0,04
4370.05N		32	0,5	0,07
4370.09		39	0,9	0,12

This very practical measuring scoop is made from food-grade polypropylene.

Graduated measuring jug, polypropylene



Code	Designation	Hcm	Liters.	Kg
4021.05N		14	0,5	0,05
4021.10N		17	1	0,1
4021.20N		21,5	2	0,2
4021.30N		24	3	0,3
4021.50N		27	5	0,4

Graduated in litres and millilitres. Pouring lip and handle. Can be used from 0°C to 125 °C.

Set of 4 measuring cups: 60 - 80 - 125 - 250 ml



Code	Designation	Kg
4827.02	1/4 cup - 1/3 cup - 1/2 cup - 1 cup	0,4

1/4 cup - 1/3 cup - 1/2 cup and 1 cup

Set of 4 measuring spoons : 1 / 2,5 / 5 / 15 ml



Code	Designation	Kg
4827.01	1/4 tsp - 1/2 tsp - 1 tsp - 1 tbsp	0,08

Ice-cream scoop made of cast aluminium with eutectic handle system



Code	Designation	Lcm	Wcm	Kg	PU
4815.00N	Width of the bowl : 4,5 cm	18	4,5	0,11	5

Designed for a better productivity with its shape and the sharp edges. Equipped with a stop drop edge and a flat base : stable and practical. When gripped, the eutectic (thermoactive) handle spreads the warmth over the whole spoon as the scoops of ice-cream are being molded to shape. This allows

the scoops to be molded more easily. Waterproof. NOT dishwasher safe.

Ice-cream scoop - Stainless steel



Code	Designation	Øcm	Lcm	Liters.	Kg
4826.05N	Portion 80ml = 1/12,5 L	6,3	23,1	0,08	0,15
4826.04N	Portion 60ml = 1/16 L	5,8	22,5	0,06	0,15
4826.03N	Portion 40ml = 1/25 L	5	21,5	0,04	0,14

Funnel



Code	Designation	Øcm	Hcm	Kg
3357.12	Funnel with filter	11,6	12,9	0,13
3357.20	Funnel with filter	19,5	20,7	0,31
3356.12N		11,6	12,9	0,13
3356.20N	Funnel without filter	19,5	20,7	0,24
3357.01	All stainless-steel filter for funnel			0,02

This stainless steel funnel is available in two models, with filter (reference 3357) and without (reference 3356). The removable filter model ensures perfect hygiene. The filter fits inside funnel reference 3356

Stainless steel funnel for jam and to pour preparations in ring



Code	Designation	Kg
3356.00	2 parts for ø from 3,5 to 6 cm	0,23

This funnel is also practical to pour preparations in ring for arranging filling on a dish.



AUTOMATIC DISPENSER BY DE BUYER

Filling, Pouring, Garnishing, decorating

	3353	3354.12	3354.02	3354.52	3358.01
Capacity	0,8 L.	1,5 L.	1,9 L.	3,3 L.	0,8 L.
Nozzle	ø 7 mm 80°C max.	3 sizes: ø 8 mm and nozzles ø 4 & 6 mm	3 sizes: ø 8 mm and nozzles ø 4 & 6 mm	3 sizes: ø 15 mm and 2 nozzles ø 5 & 10 mm	2 nozzles supplied U8 & D8 Suitable for other nozzle forms
Use:					
	LIQUID FLUID	LIQUID	FLUID	THICK MOUSSES	THICK COMPACT
Sweet or savory sauce	✓	✓	✓	✓	
Hot jelly		✓	✓	✓	
Hot fruit pulp		✓	✓	✓	
Cream Thick fruit coulis				✓	
Hot sirup		✓	✓	✓	
Liqueur	✓	✓	✓		
Mousse				✓	
Cake dough					✓
Mixture for Financiers Madeleines Cakes					✓
Jam				✓	
Puff pastry					✓
Chocolate pastry				✓	✓
Sponge biscuit					✓
Caramel chaud		✓	✓	✓	
Joconde biscuit				✓	
Custard					✓
White cheese Fruit compote				✓	



BV Cert. 6034661



TEMPERATURE
RESISTANCE
+100°C / 212°F
HITZEBESTÄNDIG



LE TUBE: Pressure pastry syringe



Code	Designation	Lcm	Wcm	Hcm	Liters.	Kg
3358.01	Delivered with 2 nozzles U8 (ø11 mm) & D8 + 2 caps + biscuits kit REF 3358.94 ACCESSORIES	38,4	10,5		0,75	0,44
3358.92	Set of 2 lids for the tank					0,05
3358.93	Set of 2 lids with hole for the tank					0,05
3358.75	0,75 capacity extra tank + 2 caps ref.3358.92	19,6	8,54		0,75	0,13
3358.95	DISPLAY WITH VIDEO : - 8 boxes Le Tube 3358.01 - 9 sets of 6 Tritan nozzles (3 X 4150.02 / 3 X 4150.03 / 3 X 4150.08) - 5 tanks 3358.75 See other suitable nozzles TRITAN pages 207-211	50	39	150		15,62

Pressure syringe for effortless dosing of paste, creams and mousses. For garnishing, filling and decorating. Simple, fast and accurate work. Easier to fill than a pastry bag. 0.75 L. capacity in transparent plastic. Graduated in cl and oz. Allows the user to see how much is left.

Knob for easy setting of pressure for dosing the amount to be poured (from 1 to 5 cl). Removable and interchangeable nozzles. DESIGNED BY DE BUYER - PATENTED

Box LE TUBE PRO



Code	Designation	Lcm	Wcm	Hcm	Kg
3358.02	This box includes: - Piston syringe LE TUBE - 4 extra containers 0.75 L. - 12 nozzles with holders: 3 plain nozzles ø 6-11-13 mm 3 star nozzles B8-C8-E8 / 2 star nozzles PF10 - PF14 1 St Honoré / 1 bird nest nozzle 1 garnishing nozzle ø 6 mm 1 garnishing nozzle ø 10 mm	47	30	10	1,82

Special shortbread biscuits kit for LE TUBE

Code	Designation	Kg
3358.94	Special lid disc holder + 13 discs + 2 caps ref.3358.92 to store the paste	0,17



kit composed with a special lid (disc holder) and 13 removable decor discs.
Delivered with 2 caps ref. 3358.92
Fits on LE TUBE.



Automatic piston funnel KWIK MAX - 3,3 Liters - All stainless steel



Code	Designation	Øcm	Wcm	Hcm	Liters.	Kg
3354.52	with stand & 2 nozzles Professional model 3 sizes : ø 15 - 10 and 5 mm	20	30	38	3,3	0,95
SPARE PARTS :						
3354.51	Stand alone					
3354.79	Mechanism					

Big sizes of the integrated nozzle ø 15 mm to preserve air molecules of the preparations: saved smoothness.
Perfect for mousses, thick sauces, caramel, thick jelly or fruit coulis, etc.
All st/steel: suitable for very hot preparations.

The deep cone enables to push and pour naturally without pressure on the mixture.

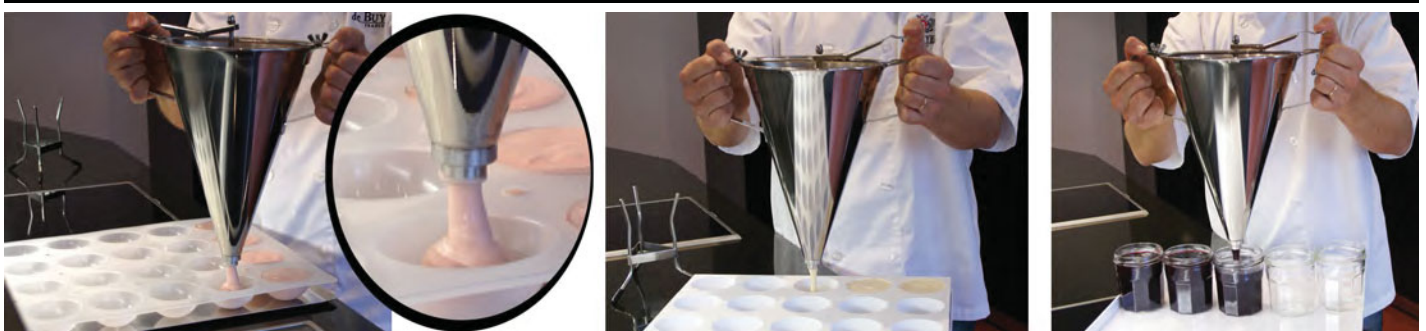

Automatic piston funnel KWIK PRO, all stainless steel



Made entirely from stainless, including nuts, wing nuts, spring... for perfect hygiene. Completely leakproof in the closed position: for creams, sauces, or liqueurs... Its ease of use makes it the universal kitchen and bakery tool for : - Garnishing plates with sauces, - Pouring jelly into a dish, - Filling small quiches, - Filling blini pans with batter, - Filling chocolate shells with liqueur, etc.

Code	Designation	Øcm	Hcm	Liters.	Th.mm	Kg
3354.00	Automatic piston funnel alone 1,9 L.	19	18	1,9	1	0,61
3354.02	Automatic piston funnel with stand 1,9 L.	19	18	1,9	1	0,78
3354.10	Automatic piston funnel alone 1,5 L.	17,5	16,5	1,5	1	0,55
3354.12	Automatic piston funnel with stand 1,5 L.	17,5	16,5	1,5	1	0,72
3354.01	Non-slip stainless steel stand		15		6	0,17
SPARE PARTS FOR FUNNEL :						
3354.92	Central closed nut					
3354.93	Wing nut					
3354.94	Spring					
3354.95	Set of two nozzles - 4 and 6 mm					
3354.89	Mechanism 1,5 L (piston, tie bar, lever, spring)					
3354.99	Mechanism 1,9 L (piston, tie bar, lever, spring)					



KWIK - Mini Piston funnel 0,8 liter - Stainless steel



Code	Designation	Øcm	Lcm	Wcm	Hcm	Liters.	Th.mm	Kg
3353.00	Black	15	18,5	15	15,5	0,8	0,4	0,25
3353.20	Green	15	18,5	15	15,5	0,8	0,4	0,25
3353.30	Orange	15	18,5	15	15,5	0,8	0,4	0,25
3353.40	Red	15	18,5	15	15,5	0,8	0,4	0,25
3353.60	Fushia	15	18,5	15	15,5	0,8	0,4	0,25
SPARE PARTS FOR FUNNEL :								
3353.96	kit nozzle nut siphon							
3353.95	Nozzle							
3353.94	Spring							

Stainless steel and plastic. Professional standard.
 This mini piston funnel comes with an outlet (7 mm dia. nozzle) and is completely impermeable.
 The funnel is practical and its low capacity (0.8 L) makes it ideal for dispensing small portions of sauce or cream, e.g. for garnishing dishes immediately prior to serving.
 Compact for practical storage.
 Dishwasher safe.

B BOIS utensils made of beechwood with a beeswax protective finishing.

The beech wood used is a wood coming from sustainably managed forests.

'B Bois' products are exclusively sold via physical retailers.



Rounded spatula B BOIS

Bevelled spatula B BOIS



Code	Designation	Lcm	Kg
4870.25		25	0,02
4870.30		30	0,03
4870.35		35	0,05
4870.40		40	0,07

Code	Designation	Lcm	Wcm	Hcm	Kg
4872.25		25	5	0,5	0,02
4872.30		30	5	0,5	0,02
4872.35		35	5,5	0,7	0,03
4872.40		40	6	0,7	0,05

Mixing spoon B BOIS



Code	Designation	Lcm	Wcm	Hcm	Kg
4871.20		20	4,5	1,5	0,02
4871.25		25	4,5	1,5	0,02
4871.30		30	5	1,5	0,03
4871.35		35	5,5	1,5	0,05
4871.40		40	6	1,5	0,07

Pointed spoon B BOIS



Code	Designation	Lcm	Wcm	Hcm	Kg
4874.00	Special sauce	30	5	1,5	0,04
4874.01	Special for risotto	30	5	1,5	0,03

Large spatula B BOIS



Code	Designation	Lcm	Wcm	Hcm	Kg
4875.30		30	8	2	0,05

Crepe spatula B BOIS



Code	Designation	Lcm	Wcm	Hcm	Kg
4873.00		30	4,5	0,5	0,02

Round crepe dough spreader B BOIS



Crepe dough spreader B BOIS



Code	Designation	Lcm	Wcm	Hcm	Kg
4873.01		20,5	16	1,5	0,01

Code	Designation	Lcm	Wcm	Hcm	Kg
4873.02		20	16	3	0,02

Set of 10 mini spatulas B BOIS



Code	Designation	Lcm	Wcm	Kg
4873.04		14	4	0,08

Salad servers B BOIS



Code	Designation	Lcm	Wcm	Hcm	Kg
4876.00		25	5,5	1,5	0,05

Toast tong B BOIS



Code	Designation	Lcm	Wcm	Hcm	Kg
4876.01		21	5	3	0,03



Utensils B BOIS made of old time finishing stainless steel and wooden handle



Code	Designation	Lcm	Wcm	Kg
2701.00	Slotted spoon	33,5	6,5	0,1
2701.01	Spoon	33,5	6,5	0,1
2701.02	Ladle	34	9	0,15
2701.03	Masher	29	7,5	0,14
2701.04	Skimmer	36,5	11	0,15
2701.05	Plain spatula	35	8	0,13

Beechwood handle with beeswax finish.

Utensils B BOIS made of old time finishing stainless steel and wooden handle



Code	Designation	Lcm	Wcm	Kg
2701.06	Slotted spatula	35	8	0,11
2701.07	Flexible turner	30	8	0,07
2701.08	Cake server	27,5		0,07
2701.09	Spaghetti spoon	33	7	0,11
2701.10	Fork	32	3,5	0,08

Beechwood handle with beeswax finish.

Wall hanging bar for utensils with 8 removable hooks - Stainless steel



Code	Designation	Lcm	Wcm	Th.mm	Kg
4720.00		44	2,4	2,5	0,36

Heavy duty 2.5-mm thick stainless steel : do not distort. Brushed stainless steel. Practical in order to have all ustensils at hand. Sliding hooks allow an easier use. Suitable for both utensils equipped with a hook and utensils provided with a hanging hole.

Wire skimmer, extra-strong stainless steel



Code	Designation	Øcm	Lcm	Kg
2601.12N	L. Handle 34 cm	12	34	0,24
2601.14N	L. Handle 35 cm	14	48	0,27
2601.16N	L. Handle 36 cm	16	38	0,29
2601.18N	L. Handle 41,5 cm	18	56	0,35
2601.20N	L. Handle 43,5 cm	20		0,38
2601.22N	L. Handle 45 cm	22	64	0,41

The wire deep-fry skimmer lets you recover and strain food floating in the cooking liquid.



Meat fork



Code	Designation	Lcm	Wcm	Th.mm	Kg
3170.40	L. Handle 30 cm While stocks last	38	4,5	1,5	0,17
3170.50	L. Handle 38 cm While stocks last	48	4,5	1,5	0,21

Heavy duty range. Stainless steel. The grapplers are made from one piece, a guarantee of robustness. The handle is wide and very rigid and its ergonomic shape lets you insert your thumb. This stops the utensil from slipping round even in greasy or sticky hands.

Stainless steel one-piece ladle



Code	Designation	Øcm	Lcm	Hcm	Liters.	Th.mm	Kg
3021.06	L. Handle 28 cm	6	32,5	3	0,05	1,2	0,1
3021.08	L. Handle 28 cm	8	36	3,7	0,13	1,2	0,15
3021.10	L. Handle 32 cm	10	42	4,7	0,25	1,2	0,24
3021.12	L. Handle 35 cm	12	45	5,7	0,45	1,2	0,29
3021.14	L. Handle 43 cm	14	53	6,5	0,67	1,5	0,48
3021.16	L. Handle 43 cm	16	55,5	8	1	1,5	0,49
3021.20	L. Handle 51,5 cm	20	72	9,7	2,06	1,5	0,71

Single-piece ladles are manufactured in one piece, a guarantee of robustness. The handle is wide and very rigid; its ergonomic shape lets you insert your thumb. This stops the utensils from slipping

round even in greasy or sticky hands. This good handhold avoids a lot of fatigue. The slope of the handle suits all vessels, even deep ones.

Stainless steel one-piece skimmer



Code	Designation	Øcm	Lcm	Th.mm	Kg
3041.08	L. Handle 28 cm	8	34,5	1,2	0,1
3041.10	L. Handle 32 cm	10	41,3	1,2	0,14
3041.12	L. Handle 35 cm	12	44,5	1,2	0,18
3041.14	L. Handle 43 cm	14	53,5	1,2	0,26
3041.16	L. Handle 43 cm	16	55,5	1,2	0,31
3041.18	L. Handle 43 cm	18	57	1,5	0,39
3041.20	L. Handle 51,5 cm	20	67,5	1,5	0,48

Single-piece skimmers are manufactured in one piece, a guarantee of robustness. The handle is wide, very rigid, and ergonomically shaped. The skimmer lets you recover food that has risen to the surface of the cooking liquid and strain it.

One-piece ladle with a spout



Code	Designation	Øcm	Lcm	Hcm	Liters.	Th.mm	Kg
3021.66	L. Handle 28 cm	6	32,5	2,8	0,05	1,2	0,1

Stainless steel. All the single-piece ladles are manufactured in one piece, a guarantee of robustness. The handle is wide, very rigid, and ergonomically shaped. Hard to get by without, the pouring ladle is ideal for pouring sauce onto a plate or dish, for serving sangria or other drinks, etc. All without dripping.

Stainless steel one-piece basting spoon



Code	Designation	Lcm	Wcm	Th.mm	Kg
3982.10	STRAIGHT - L. Handle 28 cm	37	6,6	1,2	0,14
3983.10	SIDE - L. Handle 28 cm	36	6,4	1,2	0,14

The basting spoons are all manufactured in one piece. The handle is wide, very rigid, and ergonomically shaped. The spoons allow you to scoop up the juices from meat, fish, etc., and baste with them during cooking.

Stainless steel one-piece spatula



Code	Designation	Lcm	Wcm	Th.mm	Kg
Perforated spatula					
3984.10	L. Handle 35 cm	43,5	9,7	1,2	0,18
3984.12	L. Handle 37,5 cm	47	11,6	1,2	0,22
Plain spatula					
3985.10	L. Handle 35 cm	44	9,8	1,2	0,17
3985.12	L. Handle 37,5 cm	47	11,7	1,2	0,23

Single-piece spatulas are manufactured in one piece, a guarantee of robustness. The handle is wide and very rigid and its ergonomic shape lets you insert your thumb. This stops the utensils from slipping round even in greasy or sticky hands.

Omelette turner, stainless steel



Code	Designation	Lcm	Wcm	Th.mm	Kg
3294.30		30	28	1,2	0,79

This highly practical omelette spade is for use on snack-bar griddles.

HEAVY DUTY UTENSILS

Stainless steel

Handle thickness = 2,5 mm - Professional and robust

Ergonomic shape and multi-support hook

Diameter and/or liter engraved on the handle

Ladle - Heavy quality



Code	Designation	Øcm	Lcm	Liters.	Th.mm	Kg
3130.06	L. handle : 28,2 cm	6	33,5	0,05	2,5	0,14
3130.08	L. handle : 32,9 cm	8	39	0,13	2,5	0,22
3130.10	L. handle : 36,5 cm	10	44,5	0,25	2,5	0,31
3130.12	L. handle : 40,2 cm	12	50	0,45	3	0,45
3130.14	L. handle : 41,2 cm While stocks last	14	52,5	0,67	3	0,55
3130.16	L. handle : 45,5 cm While stocks last	16	58	1	3	0,68

Heavy duty stainless steel range. The handle is wide and very rigid; its ergonomic shape lets you insert your thumb. This stops the utensils from slipping round even in greasy or sticky hands. This

good handhold avoids a lot of fatigue. The slope of the handle suits all vessels, even deep ones.

Skimmer



Code	Designation	Øcm	Lcm	Th.mm	Kg
3150.08	L. handle : 32,5 cm	8	40	2,5	0,2
3150.10	L. handle : 36,5 cm	10	45	2,5	0,25
3150.12	L. handle : 40,2 cm	12	50	3	0,36
3150.14	L. handle : 41,2 cm While stocks last	14	53	3	0,43
3150.16	L. handle : 45,5 cm	16	58,5	3	0,51

Heavy duty stainless steel range. The handle is wide, very rigid, and ergonomically shaped. The skimmer lets you recover food that has risen to the surface of the cooking liquid and strain it.

Basting spoon



Code	Designation	Wcm	Liters.	Th.mm	Kg
3143.10	Straight - L. handle 36,5 cm While stocks last	10	0,06	2,5	0,31
3144.10	Side - L. handle 36,5 cm While stocks last	10	0,06	2,5	0,31

Heavy duty stainless steel range. The handle is wide, very rigid, and ergonomically shaped. The spoons allow you to scoop up the juices from meat, fish, etc., and baste with them during cooking.

Perforated one-piece spatula



Code	Designation	Wcm	Th.mm	Kg
3141.10	L. handle : 36,5 cm While stocks last	10	2,5	0,31

Heavy duty stainless steel range. The handle is wide and very rigid

and its ergonomic shape lets you insert your thumb. This stops the utensils from slipping round even in greasy or sticky hands.

Plain spatula



Code	Designation	Wcm	Th.mm	Kg
3142.10	L. handle : 36,5 cm While stocks last	10	2,5	0,31

Heavy duty stainless steel range. The handle is wide and very rigid

and its ergonomic shape lets you insert your thumb. This stops the utensils from slipping round even in greasy or sticky hands.

Ladle



Code	Designation	Øcm	Lcm	Liters.	Th.mm	Kg	PU
3136.08	Pizza ladle, flat bottom (1) L. Handle 28 cm	8,2	32	0,15	0,8	0,13	5
3135.04	Mini ladle, round (2) L. Handle 23,5 cm - 2 cl	4	25		0,8	0,04	5
3134.06	Fruit ladle with a spout(3) L. Handle 15,5 cm	6	20	0,05	0,8	0,75	5

Welded shank. The small pouring ladles are ideal for applying toppings or for serving sauces, liqueurs, etc. The small pizza ladle holds 145ml (4 fluid oz) , which is the standard helping of tomato sauce for pizzas; its flat bottom lets you spread the sauce over the pizza pastry.

Serving spoon



Code	Designation	Liters.	Kg
2140.00	Plain	33	0,08
2140.10	Perforated	33	0,08

Spatula for non-stick frypans



Code	Designation	Lcm	Wcm	Kg	PU
4813.01N		28	6,5	0,03	5

This flexible nylon spatula has rounded edges and is recommended for use with CHOC cooking utensils as it avoids damaging their non-stick coating. Heat resistant.

Grip for hot dishes or plates



Code	Designation	Lcm	Wcm	Kg	PU
3339.00N		19	3	0,15	5

While stocks last
These extra-sturdy pincers allow you to handle hot plates or dishes safely so as to avoid burns.



Spaghetti tong



Code	Designation	Lcm	Th.mm	Kg	PU
4816.21N		20	0,5	0,06	5

Spring tongs that enable spaghetti to be held cleanly during serving. These tongs are also suited to serving grated raw vegetables.

Plastic utility tong



Code	Designation	Lcm	Kg
4789.00		30	0,13
	While stocks last		

Utility tong with silicone-coated ends. Perfect for using in nonstick pans.
Adjustable grip

Utility tongs



Code	Designation	Lcm	Th.mm	Kg	PU
4788.24N		24	0,5	0,12	12
4788.30N		30	0,5	0,15	12
4788.40N		40	0,5	0,2	12

The large model is very practical for oven ranges, grills, barbecues...

Skewer, stainless steel



Code	Designation	Lcm	Th.mm	Kg
3401.25	Set of 10	25	2	0,01
3401.30	Set of 10	30	2	0,01
3401.35	Set of 10	35	2	0,01
3401.40	Set of 10	40	2	0,02

Available 25 to 40cm (8" to 12") long, these stainless skewers are made from 2mm (14 gauge) stainless steel and will not bend. The pointed end allows food to be skewered easily.



Stainless steel tweezer with curved end



Code	Designation	Lcm	Kg
4239.15		16	0,02
4239.30		30	0,08
4239.35		35	0,17

Tweezer for picking up ingredients and easily handling them, from the thinnest one (herbs, flower, etc.) to the largest one (piece of meat). For serving up and decorating plates.

Stainless steel straight tweezer



Code	Designation	Lcm	Kg
4238.15		16	0,02
4238.25	L. blade 25 cm	25,5	0,05
4238.30		30	0,08

Tweezer for picking up ingredients and easily handling them, from the thinnest one (herbs, flower, etc.) to the largest one (piece of meat). For serving up and decorating plates.

Stainless steel curved tweezer



Code	Designation	Lcm	Kg
4237.20		20	0,03

Tweezer for picking up ingredients and easily handling them. For serving up and decorating plates.

The UNIVERSAL WHISK by DE BUYER

To Mix, Beat, Aerate, Emulsify...

The essential utensil for cooking and patisserie :
the whisk de Buyer is available
in 7 sizes for preparing :
Sauces, emulsions, creams, dough, batter...

Göma
Fouet Universel

Stainless steel wires
Spring quality
Do not loosen
from handle

Perfectly hygienic
Can be sterilized

Hole :
Easy to hang
and to drain

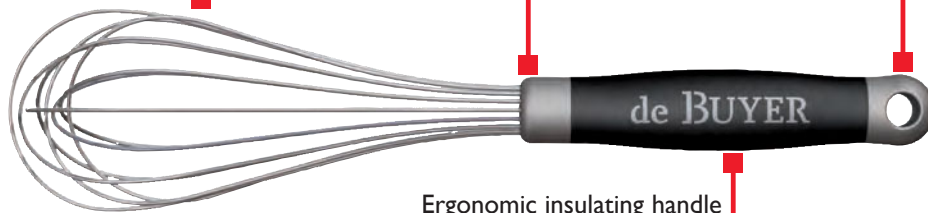

Ergonomic insulating handle



Anti-slip handle with curved design: the whisk will not fall into the pan.

HEAVY DUTY
PROFESSIONAL
ERGONOMIC

Overmoulding with TPE
(Thermo Plastic Elastomer)



Polypropylene



2 possibilities
to use the whisk



THE LINE

2610.20 Universal whisk with slim handle L. 20cm. Perfect for using in small pans for sauces.
2610.25 Universal whisk with slim handle L. 25cm
2610.30 Universal whisk with slim handle L. 30cm

The handle of the smaller whisks L. 25 cm and 30 cm is different : Slimmer to ensure comfort for all as well as smaller hands.

2610.35 Universal whisk L.35 cm
2610.40 Universal whisk L.40 cm
2610.45 Universal whisk L.45 cm
2610.50 Universal whisk L.50 cm

EGG-WHITE ROUNDED WHISK :

2611.35 Universal whisk L.35 cm
2611.45 Universal whisk L.45 cm

PERFECT HYGIENE

Can be sterilized
Dishwasher safe



For a standard domestic use
choose a maximum size L. 35 cm for whisks and spatulas



Universal whisk for cooking and patisserie GÖMA, polypropylene handle



Code	Designation	Lcm	Wcm	Kg
2610.20	St/steel wire ø 1,4 mm	22,43	5	0,06
2610.25	St/steel wire ø 1,4 mm	26,5		0,08
2610.30	St/steel wire ø 1,8 mm	32		0,14
2610.35	St/steel wire ø 1,8 mm			0,6
2610.40	St/steel wire ø 1,8 mm	41,5		0,19
2610.45	St/steel wire ø 1,8 mm	46,5		0,23
2610.50	St/steel wire ø 1,8 mm	50		0,25

The essential utensil for cooking and patisserie : the professional whisk de Buyer with stainless steel wires -spring quality- Encased wires: perfectly hygienic and watertight. Ergonomic and anti-slip comfortable handle. Easy storage with its hole. Perfect hygiene : Can be sterilized - Perfectly watertight - Dishwasher safe

Egg-whites whisk GÖMA,, polypropylene handle



Code	Designation	Lcm	Kg
2611.35	St/steel wire ø 2 mm	35	0,18
2611.45	St/steel wire ø 2 mm	45	0,23

This whisk has a large head and hard springy wires. It is specially designed for beating egg-whites until stiff.



Rubber flexible scraping spatula Maryse



Code	Designation	Lcm	Kg
4891.24N	L. handle 18 cm	29	0,07
4891.34N	L. handle 24 cm	37,3	0,1
4891.42N	L. handle 30 cm	43	0,11

A must for pastrycooks, the "Maryse" spatula is flexible and enables containers of all shapes to be scraped out efficiently, recovering all the mixture. Maryse DE BUYER : Non-scratching utensil

- Built-in hook to prevent slippage into bowls - Spoon-shaped blade ideal for scooping and spreading - Dishwasher safe - Maximum heat exposure 100°C (212°F).

One-piece spatula - high temperature (+260°C) - Nylon handle and silicone blade



Code	Designation	Lcm	Kg
4740.24N		25	0,08
4740.34N		35	0,11
4740.42N		45	0,13

This flexible spatula makes easy to remove sauces from hard-to-reach spots. Resists to +260°C / 500°F. Keeps out bacteria thanks to one piece construction: silicone blade and plastic handle are moulded together. Easy cleaning - Dishwasher safe.



White spatula made of polyglass - 220°C-resistant (470°F)



Code	Designation	Lcm	Kg	PU
4745.25		25	0,04	6
4745.30		30	0,05	6
4745.35		35	0,06	6
4745.40		40	0,08	6
4745.45		45	0,1	6
4745.50		50	0,12	6

Robust and hygienic thanks to the non-porous composite material "polyglass" (polyamid/ glass). The cleaning is easy (dishwasher safe) and the spatula can be sterilized. The rounded shape of the spatula - without edge - enables one to efficiently scrape out the pan. The end of the handle has a rim to prevent the spatula falling into the preparation.

Spatula made of high quality stainless steel

Mirror polished blade :

- Easy spreading
- Avoids risk of rust - Dishwasher safe

High flexible blade

Thinned blade : more thin on the end for a better flexibility and a precise spreading work

Ergonomic handle

- Robust and resistant made of polyamid reinforced with fiberglass
- Anti-slip carbon texture
- Slot for wedging the thumb + finger stopper for a good grip
- Integrated hook practical to hang the product

MADE IN FRANCE



Cranked pastry spatula FKOfficium



Code	Designation	Lcm	Wcm	Kg
4231.15	L. Blade 15 cm	33,5	3,5	0,12
4231.20	L. Blade 20 cm	38,5	3,5	0,13
4231.25	L. Blade 25 cm	43,5	3,5	0,15
4231.30	L. Blade 30 cm	48,5	3,5	0,16

With its angled handle, this spatula makes it easy to spread and level out pasty substances.



Straight pastry spatula FKOfficium

Code	Designation	Lcm	Wcm	Kg
4230.15	L. blade 15 cm	29	3,5	0,11
4230.20	L. blade 20 cm	34	3,5	0,12
4230.25	L. blade 25 cm	39	3,5	0,13
4230.30	L. blade 30 cm	44	3,5	0,14



This flat spatula has a rounded end and is ideal for spreading, smoothing, and handling pastries.

Mini cranked pastry spatula FKOfficium

Code	Designation	Lcm	Wcm	Kg
4231.08	Pointed blade 8 cm	21	2	0,04
4231.09	Rounded blade 9 cm	22	2	0,04
4231.12	Rounded blade 12 cm	25	2,4	0,05



Stainless steel flexible turner FKOfficium

Code	Designation	Lcm	Wcm	Kg
4235.00	L.blade 17 cm	31	7,8	0,1



This food turner is made from forged stainless steel. Its springiness makes food easy to handle and turn.

Triangular spatula FKOfficium

Code	Designation	Lcm	Wcm	Kg
4233.01	L. blade 8 cm	26,5	8	0,11



With its special shape, this spatula lets you clean grids and hotplates. Its width and sharp angles also allow you to cut or spread pasty substances or to peel chocolates off their baking sheets.

Cranked spatola FKOfficium inox

Code	Designation	Lcm	Wcm	Kg
4232.00	L. blade 12 cm	30	9	0,14
4232.01	Slotted - L. blade 12 cm	30	9	0,12



With its angled handle and rigid blade, this spatula lets you scoop up and turn over hamburger steaks and other meats on snack-bar griddles.

Cranked service spatula FKOfficium

Code	Designation	Lcm	Wcm	Kg
4236.00		26,5	5	0,07
4236.01	Slotted	26,5	5	0,06



Genoise cutter FKOfficium

Code	Designation	Lcm	Wcm	Th.mm	Kg
4234.25	L. blade 25 cm	39,5	3,5	2	0,14
4234.35	L. blade 35 cm	50	3,5	2	0,16



The sponge-cake slicer lets you slice sideways through sponge cakes evenly, without crumbs, so you can then fill the cake with cream or other fillings.



Seafood box



Code	Designation	Lcm	Wcm	Hcm	Kg
4683.90	Box includes : - seafood shears - 4 double seafood forks - an oyster knife	30	20	3,5	0,42

The essential seafood tools gathered in a practical and elegant box.



Seafood shears with stainless steel blades



Code	Designation	Lcm	Wcm	Th.mm	Kg
4685.00		20,7	6,5	1,5	0,11

LOCK-AND-SPRING MECHANISM FOR A STRESS-FREE AND SAFE CUT.
Cut hard shellfish leaving meat intact, without cracking nor mess. Ideal for lobster, crab, langouste, shrimp and scampi. Patented.
Large handle - Good grip for all hands. Integrated grip.
Detachable stainless steel blades for easy cleaning.

Set of 4 stainless steel double lobster forks

Code	Designation	Lcm	Wcm	Kg
4687.00	Set of 4 forks	21	1,8	0,01



DOUBLE FORK : Small and large end to easily remove meat from shellfish.
 Ideal for lobster, crab and langouste.
 Ergonomic design for good grip.
 Robust stainless steel - Dishwasher safe

Oyster knife with stainless steel blade

Code	Designation	Lcm	Wcm	Hcm	Kg
4683.00		15,7	4,5	2	0,06



Short and sharp blade made of extra hard stainless steel 420 2CR14.
 Perfectly sharp blade to easily cut the muscle of the oyster.
 Polyamide handle with fiberglass. Resistant and non-slip. Length adapted to all hands.

Ergonomic safe handle with slot for thumb and stopper.
 Handwash recommended - Dishwasher safe

Oyster mitt



Code	Designation	Lcm	Wcm	Hcm	Kg
	Extra large model - silicone				
4682.20	For right-handed Mitt on the left hand	23	17	2	0,14
4682.21	For left-handed Mitt on the right hand	23	17	2	0,14

This oyster mitt allows to maintain the oyster during opening. It can not provide a total protection against a misdirected knife. The extra arge model is suitable for the largest handles.





Pizza cutting wheel

Code	Designation	Øcm	Th.mm	Kg
4970.10N	Pizza cutting wheel	10	1	0,17



This particularly sturdy pizza cutter has an ergonomic handle for a firm grip. Its stainless steel beveled blade allows pizza to be easily cut into portions.

Stainless steel pizza ladle - Flat bottom

Code	Designation	Øcm	Lcm	Liters.	Th.mm	Kg	PU
3136.08	Pizza ladle, flat bottom (1) L. Handle 28 cm	8,2	32	0,15	0,8	0,13	5



Welded shank. The small pizza ladle holds 145ml (4 fluid oz) , which is the standard helping of tomato sauce for pizzas ø 31 cm; its flat bottom lets you spread the sauce over the pizza pastry.

Perforated pizza screen for cooking - aluminium

Code	Designation	Øcm	Kg
7350.23		23	0,06
7350.28		28	0,07
7350.31		31	0,09
7350.33		33	0,1
7350.38		38	0,14
7350.43		43	0,15
7350.48		48	0,21



Perfect for making pizzas, flammenkuche savory tarts, etc. The bottom is perforated to enable you to obtain a crusty-baked pie bottom.

See our complete range of round pizza trays pages 197-198

Pizza round oven peel - Aluminium with wooden handle



Oven peel for pizza or "Flammenküche"



Code	Designation	Øcm	Lcm	Kg
7291.40	L. handle 120 cm Total length : 162 cm	40	162	0,93

Code	Designation	Lcm	Wcm	Th.mm	Kg
3293.31	Pizza square oven peel L. Handle 96 cm	128	31	1,2	1,35

The food-grade stainless steel rectangular oven spades are especially rugged and will not distort. The shank is made from round tube and its long length lets you stuff pizzas right into the heart of the oven.

Pizza oven peel, stainless steel

Code	Designation	Øcm	Lcm	Th.mm	Kg
3290.31	Pizza oven peel - L. Handle 96 cm	31	114	1,2	1,18



The stainless steel handle is made from round tubes and their long length lets you stuff pizzas right into the heart of the oven.

Pizza square oven peel - Aluminium with wooden handle



Code	Designation	Lcm	Th.mm	Kg
7293.31	L. handle 120 cm Total L. 152,5 cm	31	1,5	0,89



Scraper brush for oven, wooden handle



Code	Designation	Lcm	Wcm	Hcm	Kg
4875.70		71	11,5	5	0,28

The scraper brush is used for brushing the hearth and pushing back the embers in your wood-fired oven.

Small syrup density meter, metric

Code	Designation	Lcm	Kg
4591.00N	Grad. from 1100 to 1400 g/L	14	0,19



This professional syrup hydrometer is used for making jam, jelly, liqueur, sorbey, chutney, conserved fruits, etc. It has 2 scales : one in degree baumé (15-40° Baumé) and the other in g./ml (1100-1400 g./ml).

Mini precision balance with lid - from 0 to 500 gr.

Code	Designation	Lcm	Wcm	Th.mm	Kg
4887.00		11,5	6,4	1,8	0,13



Accurate scale with lid. Precision 0.1 gr.
Perfect for spices.
Fonction tare and auto-off.
2 batteries 1,5V supplied

Candy thermometer +80°C / +200°C with stainless steel case

Candy thermometer +80°C / +200°C with nylon case



Code	Designation	Øcm	Lcm	Kg
4884.01N	PRECISION 1/1	0,2	27,5	0,1

This thermometer is used for pastry and candy. It does not contain mercury, but a less toxic red liquid. It is calibrated to allow for immersion of the lower thinner part of the stem. The protective sleeve can be sterilized at 100°C.

The thermometer and sleeve can be washed in a dishwasher.

Code	Designation	Øcm	Lcm	Kg
4884.00N	PRECISION 1/1	0,35	27,5	0,07

This thermometer is used for pastry and candy. It does not contain mercury, but a less toxic red liquid. It is calibrated to allow for immersion of the lower thinner part of the stem. The protective sleeve can be sterilized at 100°C. The thermometer and

sleeve can be washed in a dishwasher.

Stainless steel oven thermometer - precision from +50°C to + 300 °C

Code	Designation	Wcm	Hcm	Kg
4885.01	Precision 1/1	6	7	0,54



To check the temperature in the oven during cooking. Easy cleaning with water and soap.

Small plastic thermometer - from -40°C to 40°C

Code	Designation	Lcm	Wcm	Hcm	Kg
4761.00N	From -40°C to +50°C	13,5	2,4	0,13	0,01



This metric thermometer goes from -40°C to +40°C and is specially adapted for the cold. The thermometer has an all-plastic body. The column is very visible.

Electronic cooking digital thermometer-timer

Code	Designation	Lcm	Wcm	Hcm	Th.mm	Kg
4885.00N	Use T° : from -25° to + 250 °C	7	6	1,8	1	0,54



This thermometer has a 1 meter (3 feet)- metal wire. The probe resists to temperatures from 0°C to 250°C. It is used to read the inner temperature of food during cooking. Instant digital readout. The stainless steel probe and wire are heat resistant. Equipped with an automatic alarm sound. There is a magnet for metal surface attachment.

Digital waterproof thermometer for meat -50°C to +200 °C

Thermometer for foie gras and ham- from + 30°C to +100°C



Code	Designation	Lcm	Kg
4881.00N	L. probe 12 cm	20	0,06

Code	Designation	Wcm	Liters.	Kg
4882.01	in a protective plastic holder	0,6	24	0,02

This electronic digital thermometer is helpful for checking the temperature of cooking meat. The probe is pointed and penetrates easily into the meat. Do not use in the oven or in microwave oven.

Kit THERMO CONNECT PRO with sensor

Code	Designation	Lcm	Wcm	Th.mm	Kg
4885.30	Kit THERMO CONNECT PRO : Case and sensor	16,5	15	5	0,15
4885.31	Sensor Thermo Connect Pro	13,5	8,3	6,1	0,05



Thermometer and hygrometer ambient + probe temperature (cable 1.5 meter) with transmission via radio frequency (868 mhz) and internet.
 Warning, monitoring and temperature recording on mobile.
 Graphic, transmission via email (csv file).
 Kit 4885.30 necessary. Do not buy a sensor alone.
 MEASURING INTERVAL : 3,5 min (except high variation and alert)
 Range : -40+60°C /20-99%
 Accuracy : +/-1°C / +/-5% - Sonde +/- 0,5°C
 Sensor : 2x1,5V AAA not included (1 year)

Infrared thermometer from -38°C to +365°C.



Code	Designation	Lcm	Wcm	Kg
4881.10		18,5	8	0,17

AUTO-OFF function . Backlight. Indicates temperature in °C or °F
 Supplied with a cover for belt.
 2 batteries 1.5V included.

Stainless steel mechanical timer with magnet



Code	Designation	Øcm	Th.mm	Kg
4650.10		6	3,8	0,09

Countdown the remaining time in red.
 Ringtone strong. It has a magnetic back.

Electronic stopwatch timer - 20 hours



Code	Designation	Lcm	Wcm
4650.00N	Timer 20 hours Stopwatch 20 minutes	50	60

This timer is a count down one (up to 19hours and 59 minutes) and is ideal for cooking in order to respect cooking time. It has a magnetic back clip and easel stand. Battery included.

UTENSILS

Polyethylene cutting board



Code	Designation	Lcm	Wcm	Hcm	Kg
4920.60N	Sharp angles	60	40	2	3,9
	White				

The polythene cutting board is more hygienic than a wooden board because of the non-porous material.

Stainless steel cutting board rack for 6 boards



Code	Designation	Lcm	Wcm	Hcm	Kg
4140.00N	Spacement 3 cm	27	31,5	27,5	1,1

This practical rack lets you stack different cutting boards away or leave them to drain after washing. It lets you easily identify and take the right board.

Alcohol gel for burning.



Code	Designation	Øcm	Lcm	Wcm	Hcm	Liters.	Kg	PU
4409.01N	Set of 2 small measures 80 gr.	9			2		0,2	6
4409.02N	Gel alcohol small measure 200 g	8,5			5		0,25	1
4409.52N	Box of 72 measures 200 gr.							1
4409.05N	Gel alcohol 1- liter bottle				23,5	1	1	12
4409.04	Gel alcohol bucket 4 kg		26	18,5			4	4

Safer than liquid methylated spirit, this alcohol gel for burning is odourless and has the same heating power as liquid methylated. This high-heat output alcohol will maintain heat for 3,5 hours per 200g shot. Meets environmental standards. ETHANOL spirit.

Foodgrade string Rotifil - Heavy duty



Code	Designation	Øcm	Hcm	Kg
4337.01	Set of 10 reels 45 gr Rotifil 2TE ø 0,8mm	6	4,8	0,45
4338.01	Reel 1 kg Rotifil 3TE ø 01,1 mm	10	14	1

High resistance to breaking. Use from -40°C to +220°C. Regular diameter - height - weight. Good whiteness Foodgrade. Suitable for direct contact with foodstuffs in compliance with legislation in force EU 10/2011. Guaranteed without formaldehyde. Slightly absorbent. Can be used in automatic machine. Made in France.

UTENSILS

Metal cleaner



Code	Designation	Liters.	Kg	PU
4200.01N	COPPER cleaner 150 ml	0,15	0,24	6

This cleaner gives brilliance back to your utensils. It is really easy to use: first, clean your pan. Wet the sponge with hot water and dip it in the cleaner. Rub the whole pan with the sponge. Then rinse it with hot water and dry it carefully.



Box of 10 neoprene pairs of handle gloves for thermic protection



Code	Designation	Lcm	Wcm	Hcm	Kg
4636.10	Small size 7 cm	24	14,5	6	0,36
4636.20	Large size 11 cm for	24	14,5	6	0,44

Fits to the handles of stewpan, sauté-pan etc. to handle without any risk of burning

Box of 10 neoprene handle gloves for thermic protection



Code	Designation	Lcm	Wcm	Hcm	Kg
4636.00		20,5	13	5,5	0,26



Made in France
GeBauer
KASSEL

PÂTISSERIE: AN ART AND A SCIENCE

When it comes to pâtisserie, you can let your imagination run wild and try out anything that takes your fancy. Our equipment has been developed to guarantee precise results and beautiful aesthetics. We work with leading pastry chefs including winners of the World Pastry Cup and the Meilleur Ouvrier de France competition who help us develop new and innovative utensils that are highly technical and brilliantly performing.

- 172 -

Stainless steel moulds
Nonstick steel moulds
Steel moulds

- 186 -

Stainless steel rings

- 197 -

Round trays

- 199 -

Baking supports & trays

- 204 -

Cutters & rolls

- 206 -

Chocolate & sugar work

- 208 -

Nozzles & pastry bags

- 224 -

Pastry accessories





Box #homemadebread

Box #HOMEMADEBREAD



Code	Designation	Lcm	Wcm	Hcm	Kg
4713.00		47,5	30	10	1,24

- Composition:
- Baking tray for 2 baguettes, nonstick steel
 - Rectangular mould, nonstick steel
 - Baker blade to slit the dough before baking bread
 - Supple plastic scraper



Box #homebaking

Box #HOMEBAKING tarts



Code	Designation	Lcm	Wcm	Hcm	Kg
3030.00		47,5	30	10	1,53

Composition :

- Perforated fluted stainless steel tart ring ø 24 cm
- Round tray made of blue steel ø 28 cm
- Round stainless steel grate with feet ø 28 cm
- Cake server made of stainless steel and beechwood handle



Box #HOMEBAKING Cakes & tarts



Code	Designation	Lcm	Wcm	Hcm	Kg
4713.03		47,5	30	10	1,56

Composition:

- Square tart mould made of nonstick steel L.23 cm
- Rectangular mould made of nonstick steel
- Square mould made of nonstick steel L.22,5 cm - Ht 5 cm





Jonathan Mougel

Meilleur Ouvrier de France (MOF) in Pâtisserie and Confectionery, 2019

"I've used De Buyer products from the very beginning of my career. Their incredible expertise has always satisfied my desire to explore and experiment. We've developed together over time, each sharing the same focus on research and innovation. De Buyer turns my ambitions into reality. Their support has always been unwavering, including when I was awarded the prestigious title of Meilleur Ouvrier de France in Pâtisserie and Confectionery in 2019."

Jonathan Mougel has come up with recipes for delicious desserts and pâtisseries, using our collection of pastry rings and forms. Discover his creations.



Tools available for in-store promotion:

- dedicated packaging
- recipes
- background visuals
- digital kits

Stainless steel long mould for yule log with removable ends - L. 30 cm



Code	Designation	Øcm	Lcm	Wcm	Hcm	Kg
3206.30	Round 6,5 cm high	7,5	30		6,5	0,6
3206.04	Round - small size 4 cm high Delivered in decorated box	4	30	4,4	4	0,21
3205.30	Square		30	6,5	6,5	0,66
3205.04	Square - Small size 4 cm Delivered in decorated box		30	4	4	
3204.30	Triangular		30	8	6,5	0,55

Stainless steel long mould to make pâtés and mousses (vegetable, meat or fish), foie gras, ice-creams, Swiss rolls, cream cakes, yule logs, etc.

Tip: the mould becomes waterproof by lining it with cling film before filling.

Our secret : a professional design with thick stainless steel to obtain a mould that keeps its shape and a uniform heat or cold distribution. Smooth surface for an elegant finish. Easy assembly and turning out thanks to the removable end caps and the smooth edges. Multiple uses : cold uses (freezer - deep freezer) and hot uses (oven- bain-marie). Do not use in microwave. Easy care of stainless steel. Dishwasher safe.

The small models can be used alone or in combination with the large standard models to make an insert in your preparation.

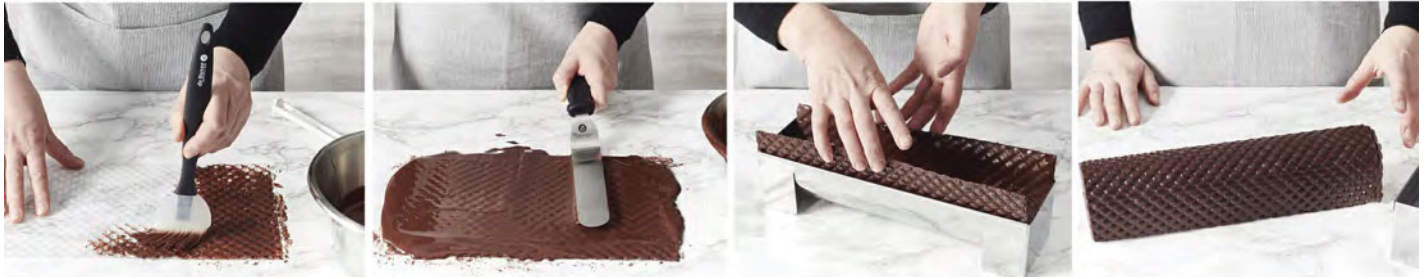

4 supple plastic sheets in relief for cream cake decoration

Code	Designation	Lcm	Wcm	Kg
	For yule log 3206.30			
4343.00		30	18,5	0,1



The supple plastic sheet is to place in the mould for rolled-cake or in the pastry frame before making your cream cake. An original relief decoration on the cake is obtained after freezing. 4 patterns are available. No oven cooking. No dishwasher. **MADE IN FRANCE**

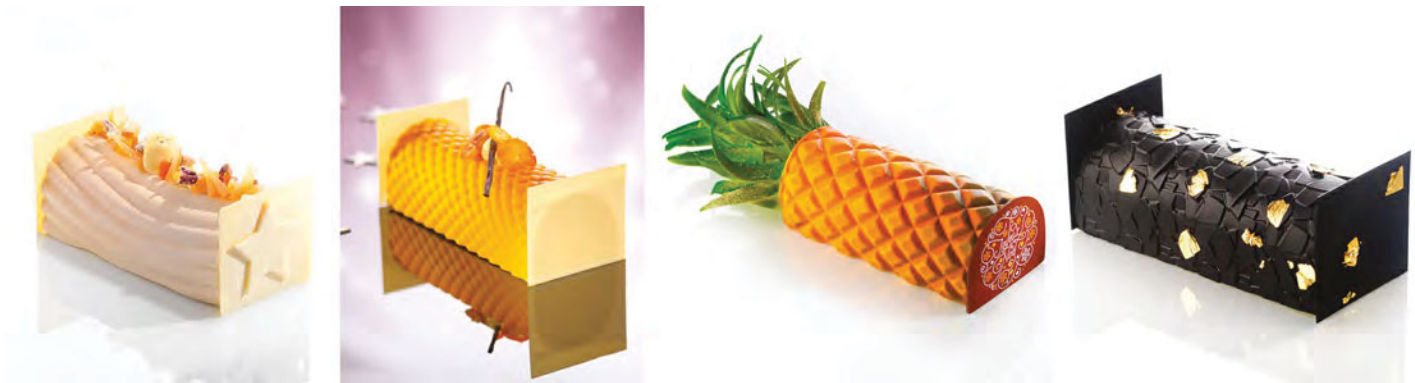

St. steel long round mould with removable ends - Professional size

Code	Designation	Lcm	Wcm	Hcm	Th.mm	Kg
3206.80		50	8	6,5	1	0,85



Ideal for making pâtés (with one or two flavours), Yule logs, Swiss rolls, etc. The walls are extra-smooth and turning out is easy. Both end plates are removable.

FABIEN PAIRON - MOF Charcutier-Traiteur

Teacher at the hotel school from Lausanne

(Ecole Hôtelière de Lausanne)

M. Pairon imagined, designed and worked on an innovative rectangular mould for "Pâté en Croûte" (meat pie):

- Practical, functional and efficient.
- Easy forming, filling, removal and storage.
- Multiuse : Pâté Croûte (rectangular meat pie), sweet and savory cakes, special breads, ginger bread , etc.
- Developed and manufactured by de Buyer in France.



Foldable stainless steel rectangular baking mould GEOFORME



Code	Designation	Lcm	Wcm	Hcm	Liters.	Kg
PERFORATED MODEL						
3210.24		24	5	6		0,55
3210.35		35	7	7,5		0,93
3210.48	Professional size only	48	9	8,5		1,28
PLAIN MODEL						
3211.24		24	5	6	0,7	0,7
3211.35		35	7	7,5	1,8	1,14
3211.48	Professional size only	48	8	8,5	3,6	1,56

Product developed in collaboration with a professional to design the first foldable mould whose fastening system can not be lost.

The perforated model allows even cooking of the dough.

Perfect for PATE EN CROUTE (meat pies), but also for breads, brioches, ginger breads or cakes.

Can be associated with baking paper for oven cooking.

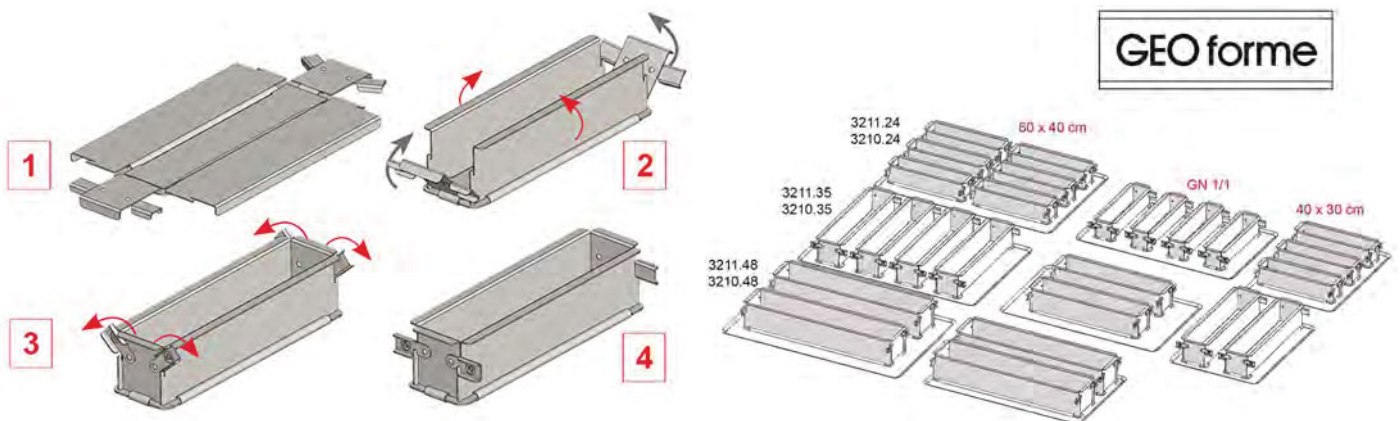

Ultra resistant stainless steel perforated mould

Suitable for intensive professional use.
 Cold or hot use without temperature limit.
 Perfectly even and optimized cooking thanks to the 2-mm perforations on the whole surface.
 Removable bottom: easy un moulding and easy cleaning.
 Easy care of the stainless steel. Dishwasher safe

Made in France

Mould supplied with a nonstick baking sheet.
 Cut to the shape of the mould. Fits perfectly into the mould. Time saving and higher productivity.
 Reusable over 200 times. Use T° from -170°C to + 260°C (-274° to 500°F)
 Removable : possible to use the st/steel mould alone or with the baking sheet.



Tools available for in-store promotion:

- dedicated packaging
- recipes
- background pictures
- digital kits



Rectangular mould with loose base with 2 baking sheets



Code	Designation	Lcm	Wcm	Hcm	Kg
3212.35		35	10,5	3,5	0,09



Dismontable round mould with 2 nonstick baking sheets

Code	Designation	Øcm	Hcm	Kg
3213.24		24	6,5	0,69



Perfect for Cheesecake, Brioches or pies.

Round fluted tart mould with loose base and 2 nonstick baking sheets

Code	Designation	Øcm	Hcm	Kg
3214.28		28	2,5	0,52



JÉRÔME LANGILLIER MAÎTRE PÂTISSIER
 WORLD CHAMPION 2009
 International consultant
 Member of the Organizing Committee of the World Pastry Cup
 Founding member of the International Desserts Academy



St/steel tube mould with its nonstick baking sheet - Concept Jérôme Langillier



A stainless steel long mould combined with a baking support. Mould: Robust. Heavy duty st/steel. Easy to assembly with the removable ends. Nonstick baking sheet made of PTFE-coated glass fiber. 0,13-mm thick. Reusable over 200 times. Fits perfectly into the mould. Easy moulding and unmoulding. Time saving and higher productivity. For sweet and savory preparations.
 Use temperature: from -170°C to +260°C.

Code	Designation	Øcm	Lcm	Wcm	Th.mm	Kg
	Perfect for baba, Terrines and leavened doughs with yeast Removable ends					
3203.20	Tube mould L.20 cm & baking sheet While stocks last	4,5	20		0,8	0,25
4344.30	Baking sheet for 3203.20		20	15,1		0,01
3203.30	Tube mould L.30 cm & baking support	4,5	30		0,8	0,33
4344.31	Baking sheet for 3203.30		30	15,1		0,01



St/steel oblique mould special Cake & baking sheet - Concept Jérôme Langillier



Code	Designation	Lcm	Wcm	Hcm	Th.mm	Kg
3208.23	Oblique long mould and baking sheet Removable ends	23	5,5	5	0,8	0,34
4344.40	Baking sheet for 3208.23 from - 170°C to + 260 °C		35	15,5		0,01

Mould: Robust. Heavy duty st/steel. Easy to assembly with the removable ends. Nonstick baking sheet made of PTFE-coated glass fiber. 0,13-mm thick. Reusable over 200 times. Fits perfectly into the mould. Cut to the shape of the mould and can be used as a template for pastry. Easy moulding and unmoulding. Time saving and higher productivity.

St/steel mould special Pâté en Croûte & baking sheet - Concept Jérôme Langillier



Code	Designation	Lcm	Wcm	Hcm	Th.mm	Kg
3202.04	Rectangular mould and baking sheet Removable ends	30	4	6	0,8	0,45
4344.20	Baking sheet for 3202.04 from - 170°C to + 260 °C	44	17			0,01

Mould: Robust. Heavy duty st/steel. Easy to assembly with the removable ends. Nonstick baking sheet made of PTFE-coated glass fiber. 0,13-mm thick. Reusable over 200 times. Fits perfectly into the mould. Cut to the shape of the mould and can be used as a template for pastry. Easy moulding and unmoulding. Time saving and higher productivity.

St. steel straight "Génoise" mould, watertight



Code	Designation	Lcm	Wcm	Hcm	Th.mm	Kg
4770.40		40	30	5	1	1,4
4770.53	GN 1/1	53	32	5	1	1,85
4770.60		59	39	5	1	2,53

The straight-sided sponge cake mould is leakproof and lets you make biscuits, flans, rice puddings, etc. Being made from stainless steel, it is perfectly hygienic and easy to keep clean.

Stainless steel "Bordelais" fluted moulds



Code	Designation	Øcm	Hcm	Th.mm	Kg
3065.35		3,5	4	0,8	0,03
3065.45		4,5	4,2	0,8	0,04
3065.55		5,5	5,5	0,8	0,06



Copper "Bordelais" fluted moulds



Code	Designation	Øcm	Hcm	Liters.	Th.mm	Kg
	TINNED COPPER					
6820.35N		3,5	3,3	0,03	0,8	0,01
6820.45N		4,5	4,2	0,06	1	0,03
6820.55N		5,5	5	0,1	1,2	0,05

These moulds allow to use the traditional method for making Bordeaux's famous crunchy Canelé cakes. The copper ensures perfect heat convection for a good caramelization of the juices and a delicious taste.

Crème-caramel mould "dariole", stainless steel



Code	Designation	Øcm	Hcm	Liters.	Th.mm	Kg	PU
3095.45N		4,8	4	0,05	0,8	0,04	6
3095.55N		5,5	5,1	0,14	0,8	0,06	6
3095.65N		6,4	6	0,18	0,8	0,08	6
3095.80		8	7,6	0,32	0,8	0,12	6

The "Dariol" mould is made from extra-smooth stainless steel for easy turning out; this way, the product has a really nice appearance when turned out. The mould is sturdy and will not distort. The shape is perfect for caramel creams.

Hemispherical dome mould, stainless steel



Code	Designation	Øcm	Hcm	Liters.	Th.mm	Kg	PU
3133.04N		4	2	0,02	1,2	0,02	10
3133.06N		6	2,7	0,05	1	0,03	5
3133.08N		8	4	0,13	1	0,08	5
3133.10N		10	4,8	0,25	1,2	0,13	5
3133.12		12	5,9	0,45	1,2	0,19	3
3133.14N		14	6,7	0,67	1,2	0,24	3
3133.16N		16	8	1	0,8	0,33	3
3133.18N		18	8,7	1,46	1,5	0,37	2
3133.20N		20	10	2,06	1,5	0,45	2

The various pastry ring shapes allow a pastrycook to make cakes which are good-looking and original, enabling him or her to stand out from the crowd. What's more, the original shape of the cream cake is itself decorative and therefore cuts back on decorating time. The st. steel ring keeps its shape throughout its use but is not too thick for good heat convection during cooking.

Professional Charlotte mould, no lid - Stainless steel



Code	Designation	Øcm	Hcm	Liters.	Kg
3125.07		6,7	4,5	0,14	0,07
3125.10		9,7	6	0,4	0,13
3125.16		16	9	1,5	0,36
3125.18		17,7	10	2,1	0,43
3125.20		19,8	11	3	0,52

Glass lid Ref.3429 are suitable to the Charlotte moulds ø 164-16-18-20 cm

The charlotte mould, with its high sides, is ideal for all sorts of preparations: Charlottes, plum duff, aspic jellies, ice-creams... The two handles allow a firm hold for easy turning out. Stainless steel guarantees good heat transmission and easy cleaning. The corresponding lid ref. 3429 or 4112 is sold separately.

Nonstick steel pastry moulds

Robust steel for good oven performance
 Steel thickness suitable for efficient heat conduction and perfect cooking.
 Nonstick coating guaranteed without PFOA or PFOS. Easy unmoulding and cleaning.



Round fluted tart mould with straight edge

Round fluted tart mould with straight edge - Loose base



Code	Designation	Øcm	Hcm	Th.mm	Kg
4705.20		20	2	0,6	0,18
4705.24		24	2,8	0,6	0,32
4705.28		28	3	0,6	0,43
4705.32		32	3	0,6	0,56

Code	Designation	Øcm	Hcm	Th.mm	Kg
4706.20		19,8	2	0,6	0,21
4706.24		23	2,8	0,6	0,32
4706.28		28	3	0,6	0,47
4706.32		32	3	0,6	0,61

Round fluted fruit tart mould



Code	Designation	Øcm	Hcm	Th.mm	Kg
4707.28		28	3	0,4	0,26

Round fluted tart mould with oblique edge

Code	Designation	Øcm	Hcm	Th.mm	Kg
4703.10		10	2	0,4	0,04
4703.12		12	2	0,4	0,05



Rectangular fluted tart mould with loose base



Code	Designation	Lcm	Wcm	Hcm	Th.mm	Kg
4708.20		20	8	2,7	0,6	0,15
4708.36		35,6	10,2	2,7	0,6	0,32

Square fluted tart mould with loose base



Code	Designation	Lcm	Wcm	Hcm	Th.mm	Kg
4709.18		18	18	2,7	0,6	0,25
4709.23		23	23	2,7	0,6	0,41

Charlotte round mould without lid



Code	Designation	Øcm	Hcm	Kg
4719.18		18	10	0,23
3429.18	GLASS LID FOR CHARLOTTE MOULD :	18		0,35

Square pastry mould



Code	Designation	Lcm	Wcm	Hcm
4700.22		22,5	22,5	5



Round pastry mould



Code	Designation	Øcm	Hcm	Kg
4718.16		16	5	0,14
4718.20		20	5	0,2
4718.26		26	5	0,3

Round pastry mould



Code	Designation	Øcm	Hcm	Th.mm	Kg
4717.20		20	3,7	0,6	0,17
4717.23		23	3,8	0,6	0,21
4717.28		28	5	0,6	0,32

Brioche fluted mould



Code	Designation	Øcm	Hcm	Th.mm	Kg
4702.10	Mini brioche mould	10	4,5	0,4	0,05
4702.22		22	8,3	0,4	0,24

Kougloff mould



Code	Designation	Øcm	Hcm	Kg
4701.22		22	10	0,29



Set of 4 "Canelés Bordelais" fluted individual moulds



Code	Designation	Hcm	Kg
4718.05		5,5	0,16

Rectangular tray of individual pastry moulds



Code	Designation	Lcm	Wcm	Hcm	Th.mm	Kg
4843.00	12 Muffins ø 7 cm Ht 3 cm	38	27	3,5	0,4	0,42
4710.12	12 Madeleines	26	20	1,4	0,4	0,2
4711.12	12 round tarts ø 7 cm	34	26	1,9	0,4	0,35
4712.06	6 Mini-Savarins ø 8 cm	21,5	31,5	2,2	0,4	0,34
4712.12	12 Mini-Savarins ø 7 cm	34,3	26,2	2,2	0,4	0,4

Round Savarin pastry mould



Code	Designation	Øcm	Kg
4712.24		24	0,41



Dismountable round Savarin pastry mould - 2 bottoms for 2 uses



Code	Designation	Øcm	Kg
4766.26		26	0,55

Dismountable round pastry mould



Code	Designation	Øcm	Hcm	Kg	PU
4844.20		20	6,7	0,27	3
4844.24		24	6,7	0,3	3
4844.26		26	6,7	0,33	3
4844.28		28	6,7	0,36	3



Oven tray with insulating double wall



Code	Designation	Lcm	Wcm	Hcm	Th.mm	Kg
4714.00		35,5	27,5	0,3	0,4	0,68

Double wall : perfect for macaroons and cookies cooking.

Rectangular cake mould with rounded edges



Code	Designation	Lcm	Wcm	Hcm	Th.mm	Kg
4715.15		15	7,5	4,8	0,4	0,1
4715.24		24	13	6,1	0,4	0,23
4715.26		26	10	6,3	0,4	0,21

Rectangular cake mould with folded edges



Code	Designation	Lcm	Wcm	Hcm	Th.mm	Kg
4716.25		25	10,8	7	0,3	0,24
4716.30		30	10,8	7	0,3	0,28

Perforated baking tray for 2 baguettes



Code	Designation	Lcm	Wcm	Hcm	Th.mm	Kg
4713.02		37	16,2	2,5	0,6	0,26

Suitable also for giving a rounded shape for chocolate decors or almond tuiles.



Blue steel pastry moulds

Robust steel for good oven performance. No coating.
Steel thickness suitable for efficient heat conduction and perfect cooking.



Round fluted tartlet mould, blue steel



Code	Designation	Øcm	Hcm	Th.mm	Kg
5356.09		9	2	0,6	0,05
5356.11		11	2	0,6	0,07
5356.14		14	2	0,6	0,1
5356.17		17	3	0,6	0,16

Fluted pie pan with loose base, blue steel



Code	Designation	Øcm	Hcm	Th.mm	Kg	PU
5357.24		24	2,5	0,6	0,34	5
5357.27		26,3	2,5	0,6	0,39	5
5357.30		29,2	2,5	0,6	0,44	5

The high-sided pie tray is ideal for making all kinds of quiches and tarts. Steel plate is a very good heat conductor and lets you make crusty pie pastries. The model with loose base is easy to use as it allows problem-free removal.

Rectangular cake mould , blue steel



Code	Designation	Lcm	Wcm	Hcm	Th.mm	Kg
5359.26		9	26	11	0,6	0,37

Baking fluted mould for "Tuile" and bread, blue steel



Code	Designation	Lcm	Wcm	Kg
5358.35		35	14	0,31

Suitable also for giving a rounded shape for chocolate decors or almond tuiles.





Créations Jonathan Mougel, MOF Pâtissier-Confiseur 2019

Perforated stainless steel tart ring with straight edge - ROUND



Code	Designation	Øcm	Hcm	Kg
HEIGHT 2 CM				
3099.01	4,7 cl	5,5	2	0,02
3099.02	6,6 cl	6,5	2	0,02
3099.03	8,8 cl	7,5	2	0,03
3099.00	11,3 cl	8,5	2	0,03
3099.04	17,3 cl	10,5	2	0,04
3099.05	24,5 cl	12,5	2	0,04
3099.06	37,7 cl	15,5	2	0,05
3099.07	53,7 cl	18,5	2	0,07
3099.08	66 cl	20,5	2	0,08
3099.09	94,2 cl	24,5	2	0,1
3099.10	127,6 cl	28,5	2	0,12
HEIGHT 3,5 CM				
3098.01		5,5	3,5	0,04
3098.02		6,5	3,5	0,04
3098.03		7,5	3,5	0,05
3098.00		8,5	3,5	0,06
3098.04		10,5	3,5	0,07
3098.05		12,5	3,5	0,08
3098.06		15,5	3,5	0,1
3098.07		18,5	3,5	0,12
3098.08		20,5	3,5	0,13
3098.09		24,5	3,5	0,15
3098.10		28,5	3,5	0,18
3006.01	Pusher for round ring ø 7.5 - 8 cm	7,4	6,1	0,05

Created in partnership with the "Ecole Valrhona", these new tart rings with small holes enable an uniform baking of the pie/tart edges. The straight edge allows an easy removal and a perfect pastry rim.





Créations Jonathan Mougel, MOF Pâtissier-Confiseur 2019

Perforated stainless steel tart ring with straight edge - SQUARE



Code	Designation	Lcm	Wcm	Hcm	Kg
HEIGHT 2 CM					
3099.19	Perforated indiv. 10 cl	7	7	2	0,04
3099.20	Perforated indiv. 20 cl	8	8	2	0,05
3099.21	40 cl	15	15	2	0,12
3099.23	60 cl	17,5	17,5	2	0,13
3099.22	80 cl	20	20	2	0,15
3006.02	Pusher for square pastry form 8 cm	7,7		6,1	0,04
HEIGHT 3,5 CM					
While stocks last					
3098.19		7	7	3,5	0,06
3098.20		8	8	3,5	0,06
3098.21		15	15	3,5	0,12
3098.22		20	20	3,5	0,16
3098.23		17,5	17,5	3,5	0,16

Created in partnership with the "Ecole Valrhona", these new tart rings with small holes enable an uniform baking of the pie/tart edges. The right edge allows an easy removal and a perfect pastry rim.

Perforated stainless steel tart ring with straight edge - HEART



Code	Designation	Øcm	Hcm	Kg
3099.50	9,5 cl - individual	8	2	0,03
3099.51	20 cl - 2 p.	12	2	0,05
3099.52	40 cl - 4 p.	18	2	0,08
3099.53	60 cl - 6 p.	22	2	0,1

Perforated stainless steel tart ring with straight edge - HEXAGONAL



Code	Designation	Lcm	Wcm	Hcm	Kg
In partnership with the "Ecole Valrhona"					
3099.60		11	11	2	0,04
While stocks last					
3099.61		22	22	2	0,1
3099.62		26,5	26,5	2	0,12
3099.63		31	31	2	0,14

Created in partnership with the "Ecole Valrhona", these new tart rings with small holes enable an uniform baking of the pie/tart edges.
The right edge allows an easy removal and a perfect pastry rim.

Perforated stainless steel tart ring with straight edge - RECTANGLE



Code	Designation	Lcm	Wcm	Hcm	Kg
HEIGHT 2 CM					
3099.30	10 cl - individual	12	4	2	0,09
3099.32	40 cl - 4 p.	25	8	2	0,1
3099.33	60 cl - 6 p.	28	11	2	0,12
HEIGHT 3,5 CM					
3098.30		12	4	3,5	0,07

Created in partnership with the "Ecole Valrhona", these new tart rings with small holes enable an uniform baking of the pie/tart edges. The right edge allows an easy removal and a perfect pastry rim.

Perforated stainless steel tart ring with straight edge - OBLONG



Code	Designation	Lcm	Wcm	Hcm	Kg
3099.40	9,3 cl - individual	14,5	3,5	2	0,06
3006.04	Pusher for oblong rings L. 14 cm	14	3,2	6,1	0,03
3099.42	40 cl - 4 p.	27	8	2	0,09
3099.43	60 cl - 6 p.	30	11	2	0,1

Perforated stainless steel tart ring with straight edge- CALISSON



Code	Designation	Lcm	Wcm	Hcm
3099.70	10 cl - Individual ring	12	5	2
3099.72	20 cl - 2 p. While stocks last	18	7,8	2
3099.73	40 cl - 4 p. While stocks last	25,5	11	2

Perforated fluted stainless steel tart ring with straight edge



Code	Designation	Øcm	Lcm	Wcm	Hcm
	ROUND				
3030.20		20			3
3030.24		24			3
3030.28		28			3
3030.32		32			3
	SQUARE				
3031.23			23	23	3
	RECTANGULAR				
3032.35			35	10	3

Perforated tart ring, rolled edge, height 2 cm



Code	Designation	Øcm	Hcm	Th.mm	Kg
3093.06		6	2	0,4	0,02
3093.08		8	2	0,4	0,03
3006.01	Pusher for round ring ø 7.5 - 8 cm	7,4	6,1		0,05
3093.10		10	2	0,4	0,04
3093.22		22	2	0,4	0,1
3093.24		24	2	0,4	0,11
3093.26		26	2	0,4	0,12
3093.28		28	2	0,4	0,13

These perforated rings are mainly designed for making pies and tarts. The pie ring is easier to use than a mould because it takes up less space on a baking plate and it's easy to turn out. The small

holes around the ring enables to suppress air bubbles to obtain a perfect crusty-baked tart.

Tart ring, rolled edge, height 2 cm



Code	Designation	Øcm	Hcm	Th.mm	Kg
3091.06N		6	2	0,4	0,02
3091.08N		8	2	0,4	0,03
3006.01	Pusher for round ring ø 7.5 - 8 cm	7,4	6,1		0,05
3091.10N		10	2	0,4	0,04
3091.12N		12	2	0,4	0,04
3091.14N		14	2	0,4	0,05
3091.16N		16	2	0,4	0,06
3091.18N		18	2	0,4	0,07
3091.20N		20	2	0,4	0,08
3091.22N		22	2	0,4	0,09
3091.24N		24	2	0,4	0,1
3091.26N		26	2	0,4	0,11
3091.28N		28	2	0,4	0,12
3091.30N		30	2	0,4	0,13
3091.32N		32	2	0,4	0,14

These stainless steel rings, 2cm high (3/4"), are mainly designed for making pies and tarts. The pie ring is easier to use than a mould because it takes up less space on a baking plate (several rings can

be positioned on the same tray). Apart from that, it's easy to turn out.

Stainless steel round ring, height 4,5 cm



Code	Designation	Øcm	Hcm	Th.mm	Kg	PU
3989.05		5	4,5	0,8	0,04	6
3989.06		6	4,5	0,8	0,05	6
3989.65		6,5	4,5	0,8	0,06	1
3989.07		7	4,5	0,8	0,06	6
3989.75		7,5	4,5	0,8	0,07	6
3989.08		8	4,5	0,8	0,08	6
3006.01	Pusher for round ring ø 7.5 - 8 cm	7,4	6,1		0,05	1
3989.10		10	4,5	0,8	0,09	1
3989.12		12	4,5	0,8	0,11	1
3989.14		14	4,5	0,8	0,12	1
3989.16		16	4,5	1	0,18	1
3989.18		18	4,5	1	0,2	1
3989.20		20	4,5	1	0,22	1
3989.22		22	4,5	1	0,24	1
3989.24		24	4,5	1	0,27	1
3989.26		26	4,5	1	0,29	1
3989.28		28	4,5	1,2	0,36	1

The 4,5 cm high (1-3/4") pastry rings are perfect for mousse-based desserts that have a Joconde biscuit bottom.

Stainless steel round standard - height 6 cm



Code	Designation	Øcm	Hcm	Th.mm	Kg
3940.12		12	6	0,8	0,14
3940.14		14	6	0,8	0,16
3940.16		16	6	1	0,23
3940.18		18	6	1	0,26
3940.20		20	6	1	0,29
3940.22		22	6	1	0,32
3940.24		24	6	1	0,35
3940.26		26	6	1	0,39
3940.28		28	6	1,2	0,4
3940.30		30	6	1,2	0,51

The 6cm high (2-1/2") pastry rings are perfect for vacherins, among other things.



St/steel round high ring -for "PAIN SURPRISE", Panettone, Wedding cakes

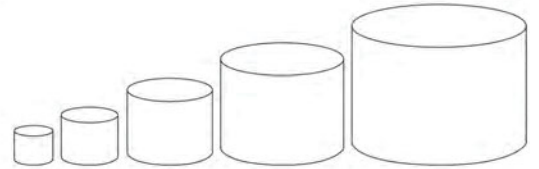

Code	Designation	Øcm	Hcm	Th.mm	Kg
3912.08	30 cl	8	6	1	0,12
3912.12	90 cl	12	8	1	0,23
3912.16	200 cl	16	10	1	0,39
3912.20	380 cl	20	12	1	0,59
3912.24	630 cl	24	14	1	0,82



Perfect for baking Pain Surprise, Panettone or wedding cakes. Suitable for oven cooking and freezing. To combine

with baking paper or baking nonstick sheets. Robust and undistortable.

Stainless steel extensible rings



Code	Designation	Hcm	Th.mm	Kg
3040.03	from ø 18 to 36 cm - Graduated Perfect for tarts - 3 cm high	3	0,8	0,15
3040.01	from ø 18 to 36 cm - Graduated	4,5	0,8	0,27
3040.02	from ø 18 to 36 cm - Graduated	6,5	0,8	0,37





Stainless steel expandable rectangular frame

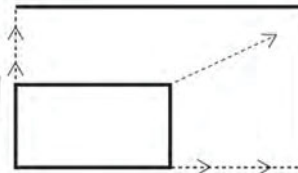

Code	Designation	Lcm	Wcm	Hcm	Th.mm	Kg
3013.21	Exp.to maxi. 40x21 cm Delivered in decorated box	21,5	11,5	7,5	1	1,07
3013.43	Exp.to maxi. 56 x84cm	43	29	5	1	1,29

Stainless steel expandable square frame

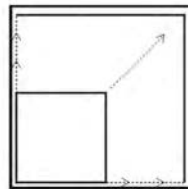

Code	Designation	Lcm	Wcm	Hcm	Th.mm	Kg
3013.16	Max. size 30x30 cm Delivered in decorated box	16	16	5	1	0,57
3013.20	Max. size 37x37 cm Perfect for trays 40x30cm Delivered in decorated box	20	20	5	1	0,69
3013.30	Max. size 5 x57 cm	30	30	5	1	0,82

Setting & maintaining the size thanks to fixing notches.
Graduated.
Perfect result thanks to the smooth inner side.
Waterproof on a flat baking support.



Pastry frame, stainless steel



Code	Designation	Lcm	Wcm	Hcm	Th.mm	Kg
3015.36	For tray 40x 30 cm	36	26	4,5	2,5	1,1
3015.49	For GN 1/1 size	49	29	4,5	2,5	
3015.35		57	37	3,5	2,5	1,12
3015.40		57	37	4	2,5	1,4
3015.45		57	37	4,5	2,5	1,6
3015.50		57	37	5	2,5	1,86
3018.40		57	9	4	2,5	1,04
3018.49	While stocks last For GN 1/1 size	49	9	4,5	2,5	

These stainless steel biscuit frames are extra thick and will not distort. They are easy to keep clean.

Stainless steel square rings, height 4,5 cm



Code	Designation	Lcm	Wcm	Hcm	Th.mm	Kg
3906.08	Small square Ht 4,5 cm	8	8	4,5	0,8	0,1
3006.02	Pusher for square pastry form 8 cm	7,7		6,1		0,04
3906.12		12	12	4,5	1	0,17
3906.16		16	16	4,5	1	0,24
3906.20		20	20	4,5	1	0,29
3906.24		24	24	4,5	1,2	0,42
3906.28		28	28	4,5	1,2	0,49

Stainless steel square rings, height 2 cm



Code	Designation	Lcm	Wcm	Hcm	Th.mm	Kg
3905.08	Small square Ht 2 cm	8	8	2	1	0,05
3006.02	Pusher for square pastry form 8 cm	7,7		6,1		0,04
3905.12		12	12	2	1	0,08
3905.16		16	16	2	1,2	0,19
3905.20		20	20	2	1,2	0,16
3905.24		24	24	2	1,2	0,19
3905.28		28	28	2	1,2	0,21

CUSTOMIZATION Consult us for your made-to-measure rings

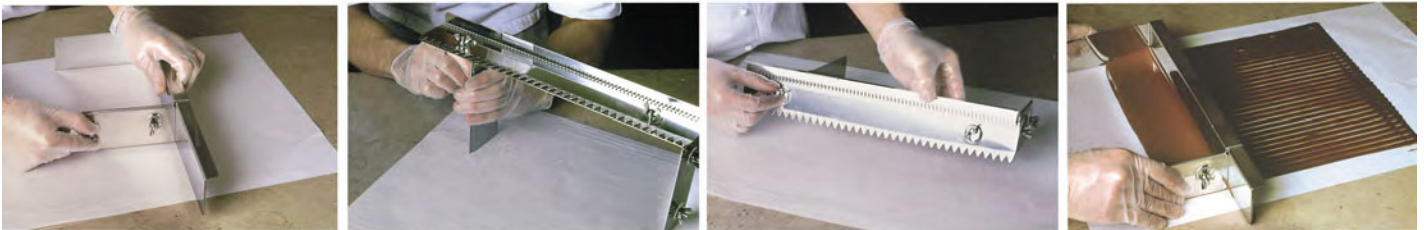

St. steel "raplette" spreader - Adjustable in width and height



Code	Designation	Lcm	Wcm	Hcm	Th.mm	Kg
3002.01	Equipped with removable decorating double comb	40	17	6	1,5	0,92
3002.00	Without decorating double comb	40	17	6	1,5	0,91
3002.99	Decorating double comb with teeth Removable - with 2 different shapes	40			1,5	0,22

The Pascal spreader lets you spread out cream or chocolate with a single action. A special feature is its adjustable width and height. These allow you to make very thin layers. Use it with or without its detachable cream-comb teeth. The cream-comb has two different triangular tooth spacings. The spreader is also handy for preparing chocolate shavings.

Stainless steel heart-shaped ring



Code	Designation	Øcm	Hcm	Th.mm	Kg	PU
	HEIGHT 40 mm					
3077.06	Heart ø 6 cm	6	4	0,8	0,06	6
3077.14	Equivalent to a 14 cm ring	14	4	1	0,16	1
3077.16	Equivalent to a 16 cm ring	16	4	1	0,18	1
3077.18	Equivalent to a 18 cm ring	18	4	1	0,19	1
3077.22	Equivalent to a 22 cm ring	22	4	1	0,23	1
3077.20	Equivalent to a 20 cm ring	20	4	1	0,22	1
3077.24	Equivalent to a 24 cm ring	24	4	1	0,24	1

The heart form lets you make cakes, ice-cream, or other desserts with an original shape that's perfect for birthdays, Mother's Day, and of course, Saint Valentine's day.

Plastic confectioner's ribbon (200 m) - 150 microns - Professional size



Code	Designation	Hcm	Kg
042002	40 mm high	4	1,65
042003	45 mm high	4,5	1,8
042004	50 mm high	5	2,14
042005	60 mm high	6	2,17

Cake-moulding tapes let you line the insides of pastry rings before moulding cream cakes in them. They then make it easy to turn out the frozen cake without damaging the exterior.

Polypropylene precut sheets - 60 microns - Professional size



Code	Designation	Lcm	Hcm	Kg
042011	For cakes ø 65 mm and Ht 40 mm 500 sheets	21,5	4	0,23

The transparent polypropylene sheet is for lining cake moulds in order to ensure easy turning out after cream cakes have been chilled. These pre-cut linings match the Fab'Rapid shapes or other individual rings and allow even better productivity.

Polypropylene confectioners' ribbon - 60 microns



Code	Designation	Øcm	Lcm	Wcm	Hcm	Kg
	Set of 100 strips					
042016	For lining cakes until max. ø8cm Delivered in decorated box		27	4,5		0,06
	10-meter roll					
042024	Ht 45 mm	5,2			4,5	0,03
042026	Ht 60 mm	5,2			6	0,04

The transparent polypropylene sheet is for lining cake moulds in order to ensure easy turning out after cream cakes have been chilled.



Stainless steel oblong individual ring



Code	Designation	Lcm	Wcm	Hcm	Th.mm	Kg
	CREATION MATHIEU BLANDIN World pastry champion 2013					
3037.14	Oblong Mathieu Blandin In partnership with the "Ecole Valrhona"	14,5	3,5	2	1	0,06
3099.40	Perforated st/steel ring with straight edge 9,3 cl - individual	14,5	3,5	2		0,06
3006.04	Pusher for oblong rings L. 14 cm	14	3,2	6,1		0,03

Stainless steel rectangular ring, sharp corners



Code	Designation	Lcm	Wcm	Hcm	Th.mm	Kg
3943.08		8	2,5	2,5	1,2	0,03
3943.10		10	2,5	3	1,2	0,04
3943.11	Rectangular ring	11,5	4	1,7		0,09
3943.12		12	4	3	1,2	0,09
3943.13		12	4	4	1,2	0,12
3942.16		16	3	2,5	1,2	0,09
3941.18		18	3	2	1,2	0,08

This shape of mould is especially well suited for arranging fillings on a dish: for coating cooked vegetables, rice, vegetarian lasagne, or adding a touch of elegance to dishes such as salmon tartare.

Stainless steel small square individual ring & pusher



Code	Designation	Lcm	Wcm	Hcm	Th.mm	Kg
3906.08	Small square Ht 4,5 cm	8	8	4,5	0,8	0,1
3905.08	Small square Ht 2 cm	8	8	2	1	0,05
3099.20	Perforated indiv. 20 cl	8	8	2		0,05
3006.02	Pusher for square pastry form 8 cm	7,7		6,1		0,04

Stainless steel small individual ring



Code	Designation	Øcm	Lcm	Wcm	Hcm	Th.mm	Kg	PU
3938.40	Round ø 60 - Ht 40 mm	6			4	0,8	0,05	6
3939.06	Round ø 65 - Ht 40 mm	6,5			4	0,8	0,05	6
3096.01	Round ø 45 - Ht 25 mm	4,5			2,5	0,8	0,02	6
3069.06	Ovale equivalent to a ø 60 mm ring		8	5,5	4,5	0,8	0,04	6
3037.06	Oblong equivalent to a ø 60 mm ring		7,4	3,3	4,5	0,8	0,04	6
3037.07	Oblong equivalent to a ø 70 mm ring		8,8	5,2	4,5	0,8	0,05	6
3037.14	Oblong Mathieu Blandin		14,5	3,5	2	1	0,06	1

Stainless steel small individual pastry ring



Code	Designation	Øcm	Lcm	Wcm	Hcm	Th.mm	Kg	PU
3937.08	small cake = ring ø7,5 cm		9,4		4,5	0,8	0,08	6
3077.06	Heart ø 6 cm		6		4	0,8	0,06	6
3139.06	Small indiv. square ring, rounded angles		6	6	4	0,8	0,05	6
3027.08	Individual		8	5	4	0,8	0,05	6

The individual shapes are made of stainless steel and used to make small cakes, mousses, individual cream cakes.

Stainless steel pastry form "Calisson"



Code	Designation	Lcm	Wcm	Hcm	Liters.	Th.mm	Kg	PU
INDIVIDUAL :								
3076.11	"Calisson" shaped ring L.11 cm	11	5	4	0,15	0,8		6
MIGNARDISE:								
3076.05	"Calisson" shaped ring L.5,5 cm	5,5	2,5			0,8	0,02	1

Stainless steel pusher for individual pastry rings and forms



Code	Designation	Øcm	Lcm	Wcm	Hcm	Kg
3006.01	Pusher for round ring ø 7.5 - 8 cm	7,4			6,1	0,05
3006.02	Pusher for square pastry form 8 cm		7,7		6,1	0,04
3006.04	Pusher for oblong rings L. 14 cm		14	3,2	6,1	0,03



Round pizza tray, heavy blue steel



Code	Designation	Øcm	Th.mm	Kg	PU
5350.20		20	1	0,26	5
5350.24		24	1	0,37	5
5350.26		26	1	0,43	5
5350.28		28	1	0,52	5
5350.32		32	1	0,65	5
5350.36		36	1,2	1	5
5350.40		40	1,5	1,2	5

This round tray with flared edges is made of blue steel plate, 1.0mm to 1.5mm thick (16-20 gauge) according to diameter. The plaque will not distort and ensures good heat transmission. This steel plate has a high-quality surface that will not stain pastry bottoms; it is micro-roughened, creating an air mattress between the food to be cooked and the metal. Ideal for pizzas.

Perforated pizza tray, heavy blue steel - Holes ø 10 mm



Code	Designation	Øcm	Kg	PU
5353.24		24	0,32	5
5353.28		28	0,45	5
5353.32		32	0,59	5

Thickness 1 mm



Round pierced pizza tray, aluminium - Hole ø 10 mm



Code	Designation	Øcm	Hcm	Th.mm	Kg	PU
7366.24		24	0,7	1	0,11	5
7366.26		26	0,7	1	0,13	5
7366.28		28	0,7	1	0,15	5
7366.32		32	0,7	1	0,2	5

The low-profile pie tray with its slightly raised edges is perfect for making pizzas, flammenkuche savory tarts, etc. The bottom is perforated to enable you to obtain a crusty-baked pie bottom.

Non-stick aluminium round tray "CHOC"



Code	Designation	Øcm	Hcm	Th.mm	Kg
8136.24	Round pizza tray	24	1	2	0,29
8136.28	Round pizza tray	28	1	2,3	0,41
8136.32	Round pizza tray	32	1	2,3	0,52

This round aluminium PTFE-coated plate is completely non-stick, tough, and easy to keep clean. The edge is slightly raised to prevent the mixture from spilling over into the oven during cooking.

Non-stick aluminium perforated round tray "CHOC"

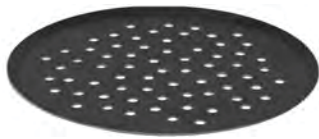

Code	Designation	Øcm	Th.mm	Kg
8137.28		28	2,3	0,36
8137.32		32	2,3	0,47

The non-stick pie tray with its slightly raised edges is perfect for making pizzas, flammenkuche savory tarts, etc. The bottom is perforated to enable you to obtain a crusty-baked pie bottom. Easy to clean.

Mould for upside down pie "Tatin", non-stick cast aluminium CHOC EXTREME Induction



Code	Designation	Øcm	Hcm	Bottom ø cm	Kg
8320.24	4/6 p.	24	5	16	0,82
8320.28	6/8 p.	28	5,5	18,5	1,2

This mould proves ideal for Tatin tarts, since it allows you to form a caramel layer directly in the mould while it's on the heat. Once the caramel is formed in the mould, just add the apple slices, cover with pastry, and place the mould in the oven. Pressure cast aluminium is ideal for providing regular cooking conditions and the thick bottom stands up excellently to deformation.



Round stainless steel grate with feet

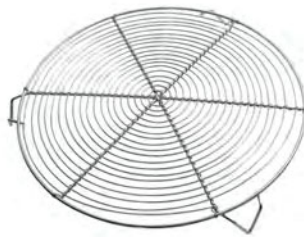

Code	Designation	Øcm	Hcm	Kg
0237.28		28	1,5	0,15
0237.32		32	1,7	0,23

For the use in domestic oven of the baking trays, baking supports and mats choose the size 40 x 30 cm max.

The GN and 60 x 40 cm sizes are suitable for professional ovens.



Steel baking tray straight edges



Code	Designation	Lcm	Wcm	Hcm	Th.mm	Kg
5362.40		40	30	2	1,2	1,57
5320.53	GN 1/1	53	32,5	2	1,2	1,97
5362.60		60	40	2	1,2	2,58

This black steel plate tray gives perfect heat transmission. This kind of steel plate is perfect for baking; it will not stain the bottoms of cakes or croissants. The surface of this steel plate is micro-roughened, creating an air mattress between the food to be cooked and the metal. Very resistant to long-lasting temperature changes.

Steel baking tray oblique edges



Code	Designation	Lcm	Wcm	Hcm	Th.mm	Kg	PU
5321.53	GN 1/1	53	32,5	1	1,2	1,71	5
5321.65	GN 2/1	65	53	1	1,2	3,28	3
5363.40		40	30	1	1,2	1,12	5
5363.60		60	40	1	1,2	2,24	5

This black steel plate tray gives perfect heat transmission. This kind of steel plate is perfect for baking; it will not stain the bottoms of cakes or croissants. The surface of this steel plate is micro-roughened, creating an air mattress between the food to be cooked and the metal. Very resistant to long-lasting temperature changes.

Aluminium baking tray - Special hard 1,5mm-thick aluminium



Code	Designation	Lcm	Wcm	Hcm	Th.mm	Kg
7362.60	Straight edges	60	40	2	1,5	1,14

This aluminium tray is specially designed for transmitting the cold in frozen food cabinets.

Aluminium baking tray - Special hard 1,5mm-thick aluminium



Code	Designation	Lcm	Wcm	Hcm	Th.mm	Kg	PU
7360.40	Oblique edges	40	30	1	1,5	0,5	5
7360.53	Oblique edges	53	32,5	1	1,5	0,8	5
7360.60	Oblique edges	60	40	1	1,5	0,95	5



Perforated flat baking tray - hard 1,5 mm thick aluminium



Code	Designation	Lcm	Wcm	Th.mm
7368.30	special for mini domestic oven	30	20	1,5
7368.40		40	30	1,5
7368.53		53	32,5	1,5
7368.60		60	40	1,5

No edge for optimized space : it enables to put a baking paper or a mat completely flat. The perforations ø 3 mm enable an homogeneous cooking.

Perforated baking tray - Special hard 1,5mm-thick aluminium



Code	Designation	Lcm	Wcm	Hcm	Th.mm	Kg	PU
7367.40	Perforated ø 3 mm, oblique edges	40	30	1	1,5	0,5	5
7367.53	Perforated ø 3 mm, oblique edges	53	32,5	1	1,5	0,6	5
7367.60	Perforated ø 3 mm, oblique edges	60	40	1	1,5	0,72	5

The perforated plate with formed edges is ideal for use in fan ovens. Example : toasting almonds. It is a perfect support for cooking in silicone pastry moulds.

Non-stick aluminium perforated rectangular pastry tray - Holes ø 3 mm



Code	Designation	Lcm	Wcm	Th.mm
8162.40		40	30	2
8162.53		53	32,5	2
8162.60		60	40	2

This non-stick tray with its slightly raised edges is perfect for making pizzas, flammenkuche, etc. The bottom is perforated to enable you to obtain a crusty-baked pie bottom. Easy to clean.

Non-stick baking tray aluminium, oblique edges, thickness 1,5 mm



Code	Designation	Lcm	Wcm	Hcm	Th.mm	Kg	PU
8161.40	Rectangular pastry tray	40	30	1	2	0,65	5
8161.60	Rectangular pastry tray	60	40	1	2	1,3	5
8161.35	GN 2/3	35	32		2	0,62	5
8161.65	GN 2/1	65	53	1	2	1,9	5
8161.53	GN 1/1	53	32,5	1	2	0,95	5

These aluminium non-stick baking trays are designed for oven-cooking and are coated with "Choc" PTFE, ensuring optimum non-stick qualities. The edges are flared, thus preventing preparations from running off the plate during cooking.

Stainless steel baking tray, straight edges, Th. 1mm



Code	Designation	Lcm	Wcm	Hcm	Th.mm	Kg
3320.53	GN 1/1	53	32,5	1,5	1	1,55
3360.40		40	30	1,5	1	1,12
3360.60		60	40	1,7	1	2,13

Made of stainless steel, this straight-edged tray is perfectly hygienic and easy to keep clean.



Stainless steel baking tray, oblique edges, Th. 1mm



Code	Designation	Lcm	Wcm	Hcm	Th.mm	Kg	PU
3321.53	GN 1/1	53	32,5	1	1	1,34	5
3321.65	GN 2/1	65	53	1	1	2,72	5
3361.40		40	30	1	1	0,9	5
3361.60		60	40	1	1	1,84	5

Made from stainless steel, this tray is perfectly hygienic and easy to keep clean.

Baking wire grate, st. steel

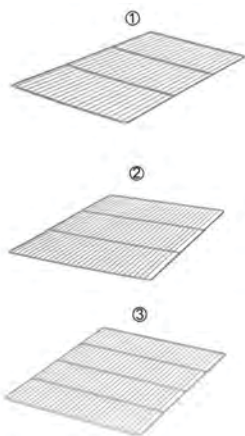

Code	Designation	Lcm	Wcm	Th.mm	Kg	PU
3330.53N	GN 1/1 - 2 crosspieces (1)	53	32,5	2	0,57	5
3330.60N	St. steel grate 60x40 cm 2 crosspieces (2)	60	40	2	0,79	5
3330.65N	GN 2/1 - 3 crosspieces (3)	65	53	3	1,7	5

This professional stainless steel cake grate is easy to keep clean. The crossbars and frame are 5mm (3/16") diameter and the grid wire 2mm (1/16"). It is very robust and will not distort.

Stainless steel fluted sheet for "Tuiles"



Code	Designation	Hcm	Th.mm	Kg
3366.35	35 x 32 cm	2	0,6	1,02

These flat stainless steel trays are rugged, easy to use, and easy to keep clean.



Silicone-coated baking paper - 100 % natural



Code	Designation	Lcm	Wcm	Hcm	Kg
PROFESSIONAL SIZE :					
4359.00	Box of 250 sheets 60 x 40 cm	60	40	2	2,74
4358.00	Box of 250 sheets GN 1/1	53	32,5	2	1,92
SMALL SIZE :					
4357.00	Roll l. 38 cm x 8 m Delivered in decorated box				0,13

Baking paper unbleached - Brown
 - Non-stick Silicone coated
 - double side
 - Reusable
 Natural & Ecological. For oven cooking (traditional and microwave) of pastry, breads and special frozen products until 220°C (428°F). 100% natural fibre 100% PEFC * & PFOA free guaranteed

Baking non-stick sheet



Code	Designation	Øcm	Lcm	Wcm	Kg	PU
from - 170°C to + 260 °C						
PROFESSIONAL SIZE :						
4344.08N	60 x 40 cm - 0,08 mm thick		60	40	0,03	10
4344.13N	60 x 40 cm - 0,13 mm thick		60	40	0,05	10
SMALL SIZE :						
Delivered in decorated box						
4344.01	40 x 30 cm		40	30	0,01	1
4344.02	Round ø 26 cm	26			0,01	1

This baking sheet is made from PTFE-coated glass fiber for perfect non-stick properties. It has the advantage of being reusable 200 times over. It proves to be very economical and can be used for lots of different applications.

Baking non-stick silicone mat



Code	Designation	Lcm	Wcm	Kg
4931.40N		40	30	0,1
4931.58N	60 x 40 cm	58,5	38,5	0,21
4931.51N	GN 1/1	51,5	31	0,14

This cooking mat is made from canvas dipped in food-grade silicone to prevent any sticking whatsoever. It replaces greaseproof paper and can stand an average 1000 visits to the oven.

Maximum temperature: 280°C (536°F).
 This mat can also be used as an underlying support for freezing and deep-freezing.
 It is easily cleaned with hot water and a sponge.





Silicone coated fiberglass baking mesh "AIRMAT™"



Code	Designation	Lcm	Wcm	Kg
4938.40		40	30	0,06
4938.58		58	38	0,11
4938.51		51	31	0,09

Perfect for baking choux paste and bread & tart doughs. Ideal to bake rawfrozen doughs. Can be used as a freezing support. Use T°: -55°C à +280°C (-67°F to +536°F). Ventilated fabric for an homogeneous cooking and crispy dough bottoms.

Silicone-coated nonstick fiberglass fabric: do not grease. The baking mat is to combine with a perforated aluminium oven tray.

Non-stick silicone pastry mat with marks for Macarons cooking



Code	Designation	Lcm	Wcm	Th.mm	Kg
	Circles ø 15 and 35 mm -40°C / + 230°C (-40°F / +446°F)				
4935.40	44 round marks	40	30	0,8	0,16
4935.60	88 round marks	60	40	0,8	0,21

Drawings ø 35 mm are really useful for covering the tray keeping lines for filling with a pastry bag for Macarons. The small circles ø 15 mm help to place the pastry bag in the centre and realize perfect macarons. This product will be useful for mass production in order to obtain always the same finishing touches. Non-stick, suitable for oven cooking.

To combine with the flat tray 7368.

Non-stick silicone pastry mat with marks

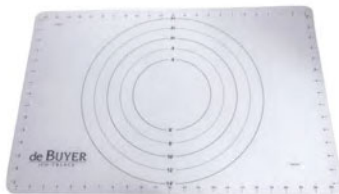

Code	Designation	Lcm	Wcm	Kg
	Non-stick recto / non-skid verso Marks for tarts ø 12 - 16 - 20 - 24 - 28 - 32 cm Graduated in cm and inches			
4937.60		60	40	0,36

This silicone pastry mat allows pie pastry to be rolled on a worktop without the need to dust it with flour. The marks indicate the upright quantity of pastry to the exact size of the tart mould. Graduated on the sides. This mat can also be used in the oven as a baking mat or as an underlying support for freezing and

deep-freezing (-60°C/+260°C). Easy cleaning.

Round-edge tray st. steel



Code	Designation	Lcm	Wcm	Th.mm	Kg	PU
	ALL STAINLESS STEEL					
3201.24		24	19	0,8	0,31	5
3201.31		31	24	0,8	0,5	5

This tea tray guarantees your preparations a particularly elegant appearance. It is easy to keep clean. The corners are rounded.



Box of 9 cutters made of polyamid



Code	Designation	Kg
4308.00	Plain round ø 2 to 10 cm	0,23
4307.00	Fluted round ø 2 to 10 cm	0,22
4304.30	Square - L.1,8 to 9,5 cm	0,27

Polyamid reinforced with glass fibre. Extra-strong foodgrade quality
 35 mm high - Round edge for comfortable handling
 Solid and resistant. One-piece construction for perfect hygiene
 Can be sterilized - T° max. 160°C

Box of 9 round cutters - stainless steel



Code	Designation	Hcm	Th.mm	Kg
3323.00N	Plain ø 3 to 11 cm	3,5	0,6	0,44
3324.00N	Fluted ø 3 to 11 cm	3,5	0,6	0,46

These professional-grade stainless steel star pastry cutting rings are very sturdy and will not distort. They will satisfy every need thanks to the different forms available. It is the tool which will satisfy your creativity thanks to the 2 different aspects suggested.

Rolling pins



Code	Designation	Øcm	Lcm	Kg
4840.01N	Beech rolling pin	5	50	0,72



Wheels for pastry in food plastic material



Code	Designation	Øcm	Lcm	Kg
	Cutting wheel for grating pastry			
4361.00N		4,5	5	0,07
4361.01N		4,5	10	0,14
	Spiked roller			
4362.00N		6,5	5	0,07
4362.01N		6,5	10	0,14

The criss-cross slitter lets you make diamond holes in the pastry for decorating pie-tops. Once the pastry has been through the roller, you just need to stretch it to obtain perfect diamond holes. The pastry-spiking roll is handy for pricking holes quickly and uniformly in strips of pastry.



Set of 10 disposable baker blades



Code	Designation	Lcm	Kg
4670.03N	Yellow-fixed blades	13	0,01
4670.05N	Blue-reversible blades	14	0,01

Baker's blades let you slit the dough before baking bread. The blade's cutting edge guarantees you a high quality cut.

Scraper



Code	Designation	Lcm	Wcm	Hcm	Th.mm	Kg	PU
3300.12	Straight dough scraper, stiff, st. steel	12	9	2,5	1	0,18	1
3301.12	Round dough scraper, stiff, st. steel	12	9	2,5	1	0,14	1
3302.11N	Dough straight scraper, supple steel	11	8,8	2,5	0,3	0,09	12
3302.12N	Dough round scraper, supple steel	11	8,8	2,5	0,3	0,08	12

The rigid or flexible pastry cutters are used for cutting out and cleaning pastry, bread dough, or pizza pastry, and also for scraping

Supple plastic scraper



Code	Designation	Lcm	Wcm	Th.mm	Kg	PU
4858.00N	Supple round scraper T° max. 60 °C	15	11	2	0,02	5

This utensil lets you scrape out a bowl to remove any mixture stuck to the walls.

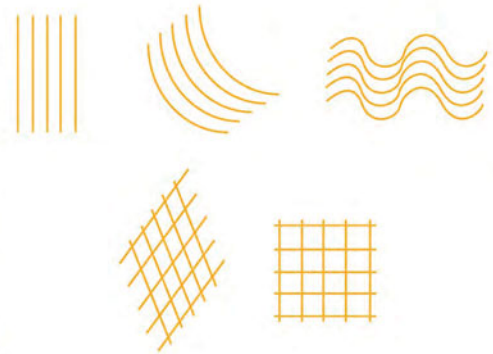

Expanding pastry cutter - Stainless steel



This expanding roller carries several stub spindles, each with a cutting wheel, and allows you to cut a series of straight strips in one go. The width is adjustable.

Code	Designation	Lcm	Wcm	Hcm	Kg
4781.00N	5 plain wheels ø 5,5 cm to cut 4 strips From 1 to 11,5 cm large	22,5	5,2	5,5	0,56
4781.01	Double 5 plain wheels and 5 fluted wheels ø 5,5 cm to cut 4 strips From 1 to 11,5 cm large	27	7,8	5,5	0,97
4781.02	6 plain wheels ø 10 cm to cut 5 strips From 1 to 12,5 cm large	27	6,4	10	0,98
	While stocks last				



Bain-marie cooker



The bain-marie cooker consists of a hollow stainless steel shell in which water is heated. It enables you to heat at lukewarm temperatures for melting chocolate or keeping sauces warm. It has a handle, which makes it easy to use. For all heat sources, including induction hobs.

Code	Designation	Øcm	Hcm	Liters.	Th.mm	Kg
3437.16N	With handle and double st. steel body	16	12,5	1,5	1	0,97

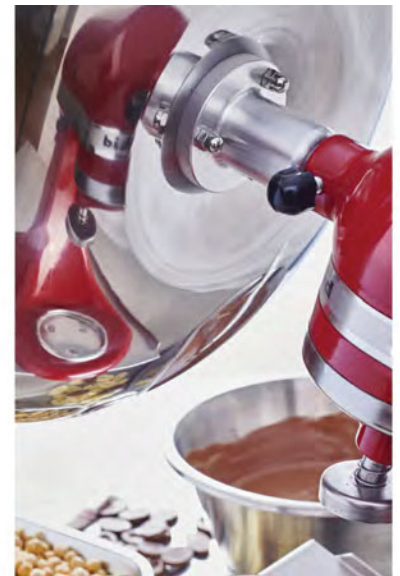

Sweet maker - Coating system



Code	Designation	Øcm	Kg
3500.00		40	4,2
	Created by Pascal Brunstein		
	Ruban Bleu 1997		



The sugar coater enables dried fruits (almonds, hazelnuts, walnuts, etc.) to be sugar coated or to be covered with chocolate, marzipan... 6 to 8kg (13-18lbs) of sweets or candies can be made in 30 minutes. Improved fastening system. The stainless steel double bell fits onto beaters :
 - KITCHENAID K5 Super Plus

- KITCHENAID ARTISAN PRO
- Dito Sama BE5 A
- Dito Sama 3500.00



Set of 5 polyethylene sheets for chocolate work



Code	Designation	Lcm	Wcm	Kg
042032		30	20	0,02

Cold use.



Sugar saucepan, massive copper, 2 spouts and st. steel cold handle



Code	Designation	Øcm	Hcm	Liters.	Th.mm	Kg
6572.20		20	11	3,4	2	1,8

This sugar saucepan with two pouring lips (for left- or right-handed people) has a stainless steel handle that remains cold so as not to burn the user's hand.

Copper massive conical jam pans with cast-iron handles



Code	Designation	Øcm	Hcm	Liters.	Th.mm	Kg
6200.38N	Conical jam pan, 1 mm th	38	15	9	1,2	1,5
6202.40N	Conical jam pan, 2 mm th	40	14,4	12	1,7	3,4

Stainless steel funnel for jam and to pour preparations in ring



Code	Designation	Kg
3356.00	2 parts for Ø from 3,5 to 6 cm	0,23

This funnel is also practical to pour preparations in ring for arranging filling on a dish.



Candy thermometer +80°C / +200°C with stainless steel case



Code	Designation	Øcm	Lcm	Kg
4884.01N	PRECISION 1/1	0,2	27,5	0,1

This thermometer is used for pastry and candy. It is calibrated to allow for immersion of the lower thinner part of the stem. The

protective sleeve can be sterilized at 100°C. The thermometer and sleeve can be washed in a dishwasher.

Pastry nozzles made of TRITAN.

Transparent black colour.
 Solid - One-piece construction.
 Perfectly smooth cone for guaranteed hygiene.
 The reinforced teeth on the fancy nozzles make high accuracy work.
 The nozzles are long enough, making them easier to insert in the bag and giving them better visibility.
 They all fit with LE TUBE de Buyer and are dishwasher friendly.
MADE IN FRANCE

Available leaflet ref.QEC21.010



Plain nozzle - Tritan



Code	Designation	Øcm	Hcm	Kg
4151.03	Ø 3 mm - U2	3,5	6	0,01
4151.06	Ø 6 mm - U4	3,5	6	0,01
4151.08	Ø 8 mm - U6	3,5	6	0,01
4151.11	Ø 11 mm - U8	3,5	6	0,01
4151.13	Ø 13 mm - U10	3,5	6	0,01
4151.15	Ø 15 mm - U12	3,5	6	0,01
4151.18	Ø 18 mm - U14	3,5	6	0,01

Saint Honoré nozzle - Tritan

Code	Designation	Øcm	Hcm	Kg
4155.09	Ø 9 mm	3,5	6	0,01
4155.11	Ø 11 mm	3,5	6	0,01



The spout has a cut-out. They are used for dressing Saint-Honorés with cream. They do a much better job than a spoon.



'Petit Four' star nozzles - Tritan

Code	Designation	Hcm	Kg
4156.10	PF10 Ø 10 mm - 14 teeth	6	0,01
4156.14	PF14 Ø 14 mm - 16 teeth	6	0,01
4156.18	PF18 Ø 18 mm - 18 teeth	6	0,01





Tritan Star nozzle



Code	Designation	Øcm	Hcm	Kg
4152.05	A8 - ø 3 mm	3,5	6	0,01
4152.09	B8 - ø 5 mm	3,5	6	0,01
4152.11	C6 - ø 8 mm	3,5	6	0,01
4152.13	C8 - ø 8 mm	3,5	6	0,01
4152.17	D8 - ø 11 mm	3,5	6	0,01
4152.19	E6 - ø 13 mm	3,5	6	0,01
4152.20	E8 - ø 13 mm	3,5	6	0,01
4152.25	F8 - ø 18 mm	3,5	6	0,01

Star ribbon nozzle - Tritan



Code	Designation	Øcm	Hcm	Kg
4153.08	8 points hole 19 x 2 mm	3,5	6	0,01

One flat side and one indented side for decorating Yule logs.



Bird nest nozzle - Tritan



Code	Designation	Øcm	Hcm	Kg
4166.01	19 holes ø3 mm	3,5	4,5	0,01



Leaf nozzle - Tritan



Code	Designation	Øcm	Hcm	Kg
4168.02	F2	3,5	6	0,01



Garnishing nozzles - Tritan

Code	Designation	Øcm	Hcm	Kg
4165.06	Nozzle ø 6 mm	3,5	9	0,01
4165.10	Nozzle ø 10 mm	3,5	9	0,01



GEO nozzle - Tritan



Code	Designation	Øcm	Hcm	Kg
4183.05	Square 5 mm	3,5	6	0,01
4183.10	Square 10 mm	3,5	6	0,01
4181.10	Triangular 10 mm	3,5	6	0,01
4182.12	Rectangular 12 x 6 mm	3,5	6	0,01
4180.14	Half ø 14 mm	3,5	6	0,01

EXCLUSIVITY DE BUYER

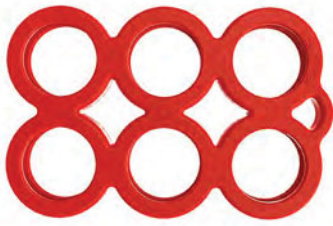

Box of 6 plain Tritan nozzles and supple holder

Box of 6 plain Tritan nozzles and supple holder



Code	Designation	Lcm	Wcm	Hcm	Kg
4150.10	6 plain nozzles - U2-4-6-8-10-12	16,5	8,5	7	0,05

Code	Designation	Lcm	Wcm	Hcm	Kg
4150.11	6 star nozzles B8-C6-C8-D8-E6-E8	16,5	8,5	7	0,05

Box supplied with an holder made in TPE for 6 nozzles Tritan. Equipped with a hole to hang. Nozzles are easy to clip, unclip, clean, dry and store. No nozzle gets lost.

Box of 6 Tritan nozzles and supple holder



Code	Designation	Lcm	Wcm	Hcm	Kg
4150.02	Set CLASSIC - 3 plain nozzles ø 6-11-13 mm - 3 Star nozzles B8-C6-E8	16,5	8,5	7	0,05
4150.03	Set CREATIVE - 2 Star nozzles PF10 - PF14 / 1 leaf nozzle - 1 ribbon nozzle / 1 bird nest / 1 St Honoré ø 9 mm	16,5	8,5	7	0,05
4150.05	Set GEO - 1 plain nozzle ø 8 mm - 5 GEO : 2 squares / triangle / rectangle / hemisphere	16,5	8,5	7	0,05
4150.07	Set STARTER - 3 plain nozzles ø 3-8-15 mm - 3 Star nozzles A8-C8-F8	16,5	8,5	7	0,05
4150.08	FILLING set - 1 plain nozzle ø 11 mm / 2 Star nozzles PF10 - PF14 - 2 filling nozzles ø 6-10 mm / 1 GEO rectangular nozzle	16,5	8,5	7	0,05

Box supplied with an holder made in TPE for 6 nozzles Tritan. Equipped with a hole to hang. Nozzles are easy to clip, unclip, clean, dry and store. No nozzle gets lost.

REF 4150.09



Box of 12 Tritan nozzles and 2 supple holders



Code	Designation	Lcm	Wcm	Hcm	Kg
4150.04	SET MIX (4150.02+4150.03) CLASSIC + CREATIF - 3 plain nozzles ø 6-11-13 mm - 3 Star nozzles B8-C6-E8 - 2 Star nozzles PF10 - PF14 / 1 leaf nozzle - 1 ribbon nozzle / 1 bird nest / 1 St Honoré ø 9 mm	21	12,5	7	0,1
4150.09	CATERER SET with : - 4 plain nozzles U4-6-8-12 - 4 star nozzles n° C6 - C8 - D8 - E6 - 1 leaf nozzle - 1 star ribbon nozzle 8 teeth - 2 St Honoré ø 9 - 11 mm	21	12,5	7	0,1



All de Buyer Tritan nozzles suits on LE TUBE ref. 3358.01 and 3358.02

LE TUBE: Pressure pastry syringe



Code	Designation	Lcm	Wcm	Hcm	Liters.	Kg
3358.01	Delivered with 2 nozzles U8 (ø11 mm) & D8 + 2 caps + biscuits kit REF 3358.94 ACCESSORIES	38,4	10,5		0,75	0,44
3358.92	Set of 2 lids for the tank					0,05
3358.93	Set of 2 lids with hole for the tank					0,05
3358.75	0,75 capacity extra tank + 2 caps ref.3358.92 + 2 caps ref.3358.92	19,6	8,54		0,75	0,13
3358.95	DISPLAY WITH VIDEO : - 8 boxes Le Tube 3358.01 - 9 sets of 6 Tritan nozzles (3 X 4150.02 / 3 X 4150.03 / 3 X 4150.08) - 5 tanks 3358.75	50	39	150		15,62

Pressure syringe for effortless dosing of paste, creams and mousses. For garnishing, filling and decorating. Simple, fast and accurate work. Easier to fill than a pastry bag. 0,75 L. capacity in transparent plastic. Graduated in cl and oz. Allows the user to see how much is left.

Knob for easy setting of pressure for dosing the amount to be poured (from 1 to 5 cl). Removable and interchangeable nozzles. DESIGNED BY DE BUYER - PATENTED

Box LE TUBE PRO



Code	Designation	Lcm	Wcm	Hcm	Kg
3358.02	This box includes: - Piston syringe LE TUBE - 4 extra containers 0.75 L. - 12 nozzles with holders: 3 plain nozzles ø 6-11-13 mm 3 star nozzles B8-C8-E8 / 2 star nozzles PF10 - PF14 1 St Honoré / 1 bird nest nozzle 1 garnishing nozzle ø 6 mm 1 garnishing nozzle ø 10 mm	47	30	10	1,82

Special shortbread biscuits kit for LE TUBE



Code	Designation	Kg
3358.94	Special lid disc holder + 13 discs + 2 caps ref.3358.92 to store the paste	0,17

kit composed with a special lid (disc holder) and 13 removable decor discs. Delivered with 2 caps ref. 3358.92 Fits on LE TUBE.



U2 - ø3mm



U3 - ø4mm



U4 - ø6mm



U5 - ø7mm



U6 - ø8mm



U7 - ø10mm



U8 - ø11mm



U10 - ø13mm



U11 - ø14mm



U12 - ø15mm



U14 - ø18mm



U15 - ø20mm



Stainless steel plain nozzle



Code	Designation	Øcm	Hcm	Kg
2111.02N		0,2	5	0,01
2111.03N		0,3	5	0,01
2111.04N		0,4	5	0,01
2111.05N		0,5	5	0,01
2111.06N		0,6	5	0,01
2111.07N		0,7	4,5	0,01
2111.08N		0,8	4,5	0,01
2111.09N		0,9	4,5	0,01
2111.10N		1	5,4	0,01
2111.11N		1,1	5	0,01
2111.12N		1,2	5	0,01
2111.13N		1,3	5	0,01
2111.14N		1,4	5	0,01
2111.15N		1,5	5,4	0,01
2111.16N		1,6	5,3	0,01
2111.17N		1,7	5,3	0,01
2111.18N		1,8	5	0,01
2111.20N		2	5	0,01
2111.22N		2,2	4,9	0,01
2111.24N		2,4	4,5	0,01

These stainless steel nozzles without welding are robust, easy to clean and hygienic. They fit onto piping bags for making patterns with cream or for filling the hollows in a baking preparation.

Stainless steel star nozzle



Code	Designation	Øcm	Kg
2112.02N	A5	0,3	0,01
2112.03N	A6	0,3	0,01
2112.04N	A7	0,35	0,01
2112.05N	A8	0,5	0,01
2112.06N	B5	0,5	0,01
2112.07N	B6	0,5	0,01
2112.08N	B7	0,6	0,01
2112.09N	B8	0,7	0,01
2112.10N	C5	0,7	0,01
2112.11N	C6	0,7	0,01
2112.12N	C7	0,7	0,01
2112.13N	C8	0,9	0,01

These stainless steel nozzles without welding are robust, easy to clean and hygienic. They fit onto piping bags for making cream patterns or for filling the hollows in a baking mixture.

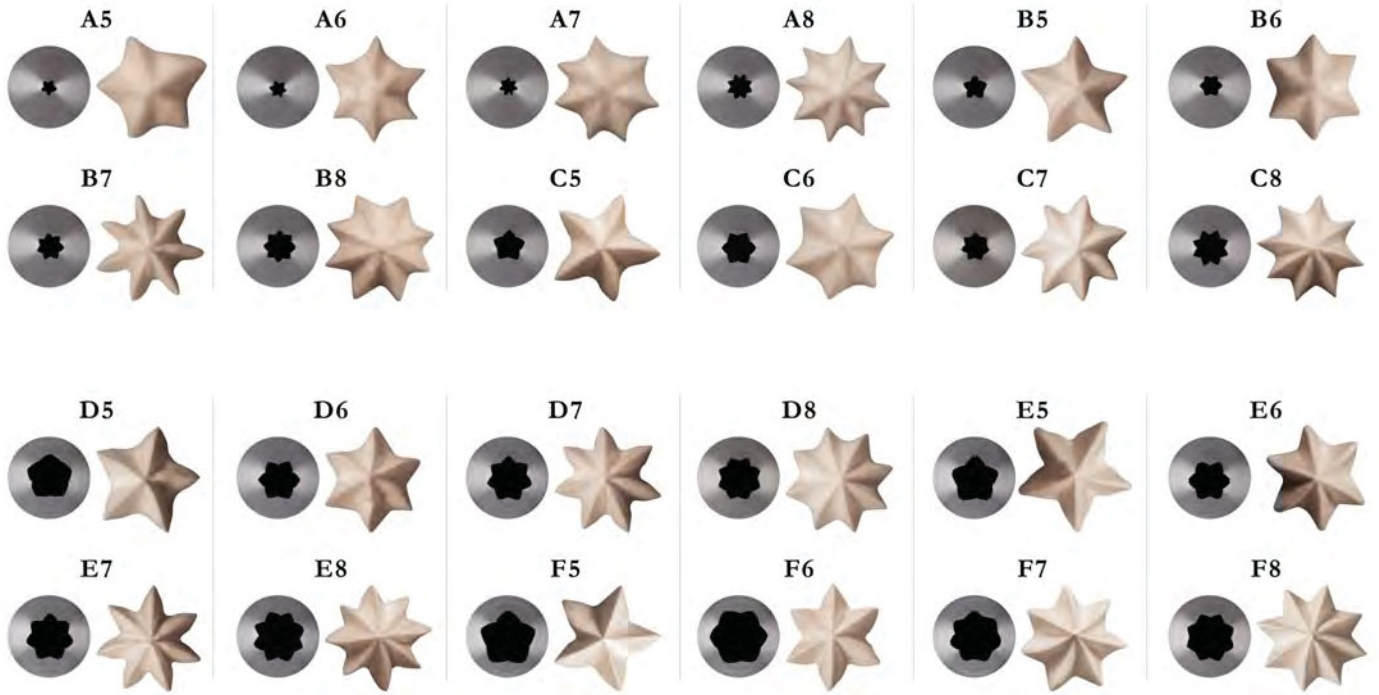

Stainless steel star nozzle



Code	Designation	Øcm	Kg
2112.14N	D5	1,1	0,01
2112.15N	D6	1,1	0,01
2112.16N	D7	1,1	0,01
2112.17N	D8	1,1	0,01
2112.18N	E5	1,3	0,01
2112.19N	E6	1,3	0,01
2112.20N	E7	1,3	0,01
2112.21N	E8	1,3	0,01
2112.22N	F5	1,8	0,01
2112.23N	F6	1,8	0,01
2112.24N	F7	1,8	0,01
2112.25N	F8	1,8	0,01

These stainless steel nozzles without welding are robust, easy to clean and hygienic. They fit onto piping bags for making cream patterns or for filling the hollows in a baking mixture.

Stainless steel ruban nozzle



Code	Designation	Øcm	Hcm	Kg
2117.10	10 x 2 mm	2,5	4,5	0,01
2117.15	15 x 2 mm	3,2	4,5	0,01
2117.20	20 x 2 mm	3,2	4,5	0,01
2117.30	30 x 5 mm	3,6	4,5	0,01



Stainless steel star ribbon nozzle



Code	Designation	Øcm	Hcm	Kg
2113.06N	6 points- hole 16 x 2 mm	2,5	4	0,01
2113.08N	6 points - hole 20 x 3 mm	3	4,5	0,01

These stainless steel nozzles without welding are robust, easy to clean and hygienic. They have one flat side and one indented side and are used for decorating Yule logs.

Stainless steel Sultane nozzle - Small size Ht 4,5 cm



Code	Designation	Hcm	Kg
2118.31	Plain	4,5	0,01
2118.12	Star	4,5	0,01

Stainless steel Sultane nozzle



Code	Designation	Hcm	Kg
2118.01	Protruding cone	6,3	0,03
2118.02	Flat cone-up	6,3	0,03

UP : outer ø35 mm
cone inside ø21 mm
ø base 55 mm



Stainless steel Sultane mini nozzle



Code	Designation	Øcm	Hcm	Kg
2118.03	ø 7 mm - 12 teeth	1,8	2,85	0,01

Stainless steel Saint Honoré nozzle



Code	Designation	Øcm	Hcm	Kg
2115.20N		0,9	5	0,01
2115.25N		1,1	5	0,01
2115.30N		1,3	5	0,01
2115.35N		1,5	5	0,01
2115.40N		1,6	5	0,01

These stainless steel nozzles are robust, easy to clean and hygienic thanks to their watertight "end-to-end" welding. The spout has a cut-out. They are used for dressing Saint-Honorés with cream. They do a much better job than a spoon.

Leaf nozzle, stainless steel



Code	Designation	Hcm	Kg
2128.02N	N° 2 - large 6 mm	6	0,01

These stainless steel nozzles without welding are robust, easy to clean and hygienic.



Rose nozzle, stainless steel - 8 points



Code	Designation	Øcm	Hcm	Kg
2129.08N		0,8	5	0,01
2129.09N		0,9	5	0,01
2129.11N		1,1	5	0,01
2129.14N		1,4	5	0,01
2129.16N		1,6	5	0,01

These stainless steel nozzles without welding are robust, easy to clean and hygienic.

Bird nest nozzle, stainless steel



Code	Designation	Øcm	Hcm	Kg
2126.00N	7 holes ø 1.3 mm	1,3	3,95	0,01
2126.01	9 holes ø 3 mm	1,9	3,95	0,01

These stainless steel nozzles without welding are robust, easy to clean and hygienic.



Bird nest nozzle, stainless steel - 3 fluted holes



Code	Designation	Øcm
2126.02		3,1

These stainless steel nozzles without welding are robust, easy to clean and hygienic.

Stainless steel nozzle - spiral effect



Code	Designation	Øcm	Hcm
2119.13	8 teeth	1,3	4,15

These stainless steel nozzles without welding are robust, easy to clean and hygienic.

Stainless steel 'Petit Four' star nozzles

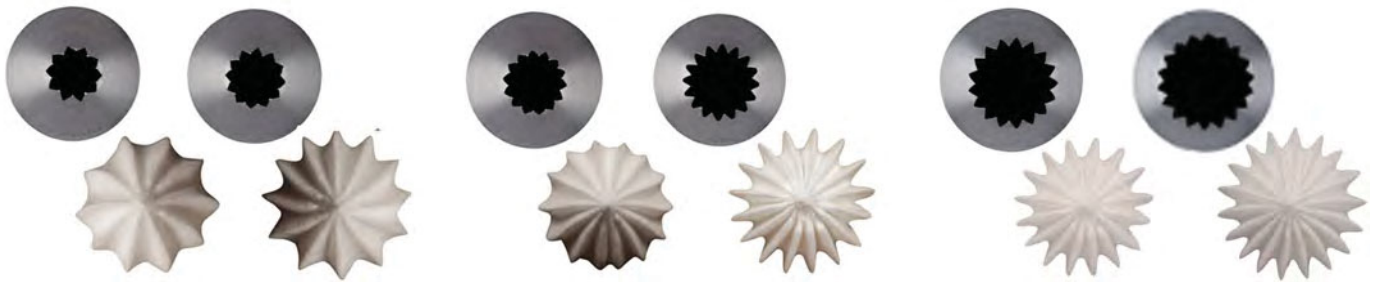

Code	Designation	Hcm	Kg
2116.07	ø 7 mm - 10 teeth	4,8	0,05
2116.08	ø 8 mm - 12 teeth	4,3	0,07
2116.10	ø 10 mm - 14 teeth	5	0,01
2116.14	ø 14 mm - 16 teeth	5,5	0,01
2116.16	ø 16 mm - 17 teeth	5,3	0,08
2116.17	ø 17,5 mm - 18 teeth	4,8	0,05

Sphere nozzle, stainless steel



Code	Designation	Øcm	Kg
2120.20	with fine streaks	2,5	0,01
2120.21	with large streaks	2,5	0,01

These stainless steel nozzles without welding are robust, easy to clean and hygienic.



Russian nozzle, stainless steel - Flower decor N°241 - N°242



Code	Designation	Øcm	Hcm
2120.01	N°241	2,67	3,85
2120.02	N°242	2,67	3,85

These stainless steel nozzles without welding are robust, easy to clean and hygienic.

Russian nozzle, stainless steel - Flower decor N°243 - N°244



Code	Designation	Øcm	Hcm
2120.03	N°243	2,67	3,85
2120.04	N°244	2,67	3,85

These stainless steel nozzles without welding are robust, easy to clean and hygienic.

Russian nozzle, stainless steel - Flower decor - N°246 - N°247

Russian nozzle, stainless steel - Flower decor N°257 - N°248



Code	Designation	Øcm	Hcm
2120.05	N°246	2,67	3,85
2120.06	N°247	2,67	3,85

Code	Designation	Øcm	Hcm
2120.08	N°248	2,67	3,85
2120.07	N°257	2,67	3,85

These stainless steel nozzles without welding are robust, easy to clean and hygienic.

These stainless steel nozzles without welding are robust, easy to clean and hygienic.

Garnishing nozzles



Code	Designation	Hcm	Kg
2125.06	Nozzle ø 6 mm	8,2	0
2125.03	Set of 3 nozzles ø 4-6-8 mm		0,01

Set of 5 stainless steel nozzles



Code	Designation	Kg
2114.05	in blister package - 2 plain nozzles ø 8 and 2 mm - 1 star ribbon nozzle 8 teeth 1 garnishing nozzle ø 6 mm - Star nozzle C6	0,06

Set of 6 stainless steel nozzles



Code	Designation	Kg
2114.00N	Set of 6 st. steel nozzles	0,04

Counter display of stainless steel nozzles and accessories



Code	Designation	Lcm	Wcm	Hcm	Kg
2130.03	Display with video screen and booklets	52,5	30	48	4,1
	50 models of stainless steel nozzles - total 241 nozzles- and accessories (adapters, scraper and pastry bags)				
	Consult us for the detailed composition.				
	Video screen runs off battery and can be recharged.				

Stainless steel pastry nozzles. Perfectly smooth. Easy cleaning. Dishwasher safe. Suitable for all piping bags.

MEGA PASTRY BOX: set of 172 stainless steel nozzles



Code	Designation	Lcm	Wcm	Hcm	Kg
2130.02	35 differents nozzles in 5 ex (except 2120.20 x 2)	30,5	21,5	8	1,55
	- 7 Plain ø 6/8/10/12/14/16/18 mm				
	- 6 Star A8/C6/D6/D8/E8/F8				
	- 2 St Honoré ø 11 mm - ø 15 mm				
	- 2 Star ribbon 6 teeth L.16 mm - L.20 mm				
	- 2 Petits Fours ø 8 mm - ø 14 mm				
	1 garnishing nozzle ø 6 mm				
	- 2 Bird nest nozzles				
	- 2 Rose nozzles ø 8 mm - ø 11 mm				
	- Ruban nozzle L.20 mm				
	- Sphere nozzle				
	- 8 Russian flower nozzles				
	- Spiral effect nozzle				

Stainless steel pastry nozzles. Perfectly smooth. Easy cleaning. Dishwasher safe. Suitable for all piping bags.

MAXI PASTRY BOX: set of 120 stainless steel nozzles



Code	Designation	Lcm	Wcm	Hcm	Kg
2130.01	24 differents nozzles in 5 ex	28	18,5	8	1,22
	- 7 Plain ø 6/8/10/12/14/16/18 mm				
	- 6 Star A8/C6/D6/D8/E8/F8				
	- 2 Star ribbon 6 teeth L.16 mm - L.20 mm				
	- 2 St Honoré ø 11 mm - ø 15 mm				
	- 2 Petits Fours ø 8 mm - ø 14 mm				
	- Garnishing nozzle ø 6 mm				
	- Bird nest nozzle				
	- Leaf nozzle N°2				
	- 2 Rose nozzles ø 8 mm - ø 11 mm				

Stainless steel pastry nozzles. Perfectly smooth. Easy cleaning. Dishwasher safe. Suitable for all piping bags.

PASTRY BOX: set of 60 stainless steel nozzles



Code	Designation	Lcm	Wcm	Hcm	Kg
2130.00	While stocks last	17,5	12,9	7,6	0,6

Stainless steel pastry nozzles. Perfectly smooth. Easy cleaning. Dishwasher safe. Suitable for all piping bags.

Adapter for nozzles made of foodgrade plastic



Code	Designation	Hcm	Kg
2114.11	Kit for large nozzles ø 35mm	5,8	0,02
2114.12	Kit for medium nozzles ø 25mm	5,7	0,03
2114.21	Kit for decor nozzles ø 20mm	3	0,02
2114.13	Set of 3 adapters for the 3 sizes of nozzles ø 35/25/20 mm		0,1

Adapters enable to change of nozzles on the same pastry bag.

Set of 26 small stainless steel decor nozzles



Code	Designation	Lcm	Wcm	Hcm	Kg
2114.20		19,2	14	4,8	0,27

Case with 26 st/steel decor noozles + an adaptator + 2 supports to make decorations in chocolate/cream/glaze for writing or creating leaves, flowers, ...
Supplied with an adapter to change nozzles

Set of 35 stainless steel pastry nozzles + 2 adaptators



Code	Designation	Lcm	Wcm	Hcm	Kg
2114.10		30	24	6,3	0,87

Case with a traditional pastry assortment of 35 nozzles:
 - 10 plain nozzles
 - 15 star nozzles
 - 5 nozzles for Petit Four
 - 2 nozzles for Rose
 - 2 ribbon nozzles
 - 1 nozzle to garnish .
 Supplied with adaptors to change nozzles on the same pastry bag.

Nylon extra supple pastry bags



Code	Designation	Lcm	Kg
4859.34		34	0,01
4859.46		46	0,01

The professional re-usable pastry bags made of coated cotton are particularly supple. They have a string, but no hem. They are lined and then watertight.



Cotton pastry bags



Code	Designation	Lcm	Kg	PU
4856.25N	pastry bag 25 cm	25	0,04	6
4856.30N	pastry bag 30 cm	30	0,04	6
4856.35N	pastry bag 35 cm	35	0,05	6
4856.40N	pastry bag 40 cm	40	0,06	6
4856.45N	pastry bag 45 cm	45	0,07	6
4856.50N	pastry bag 50 cm	50	0,11	6
4856.60N	pastry bag 60 cm	60	0,16	6
4347.05N	Set of 5 cotton pastry bags 30/35/40/45 and 50 cm long		0,13	1

The professional re-usable pastry bags made of coated cotton are particularly supple. They have a string, but no hem. They are lined and then watertight.

Supple pastry bag made of polyurethane



Code	Designation	Lcm	Wcm	Kg
4347.35		35	20	0,02

Foodgrade polyurethane. This innovative material gives to the bag high resistance, flexibility and softness. It has a smooth surface inside which make easier the outflow of the product and rough outside for a better handle. Thanks to a special welding of the bag, a high hygienic safety is guaranteed. Easy cleaning. Dishwasher safe. Resists until 60°C maximum.

Supple pastry bag made of polyurethane + 2 stainless steel nozzles



Code	Designation	Lcm	Wcm	Hcm	Kg
4347.03	Pastry bag L. 35 cm Plain nozzle 2111.10N Ø 10 mm Star nozzle C6 Packed in plastic box	24	4	4	0,06

Foodgrade polyurethane. This innovative material gives to the bag high resistance, flexibility and softness. It has a smooth surface inside which make easier the outflow of the product and rough outside for a better handle. Thanks to a special welding of the bag, a high hygienic safety is guaranteed. Easy cleaning. Dishwasher safe. Resists until 60°C maximum.

Roll of 20 disposable pastry bags - Polyethylene



Code	Designation	Øcm	Lcm	Wcm	Kg
4348.02		4	23	4	0,14
	Delivered in decorated box				

The throw-away piping bags have the same use as the nylon ones but without the inconvenience of cleaning and upkeep. Reinforced edges. T° 70°C max.

Roll of 100 disposable pastry bags - Blue polyethylene



Code	Designation	Lcm	Liters.	Kg
4349.55		55	1,7	1,35

90 microns. Reinforced edges. T° 70°C max.
Roll in a dispenser box.

Roll of 100 disposable pastry bags - Polyethylene



Code	Designation	Lcm	Liters.	Kg
4348.30N	30 cm long	30	0,25	0,6
4348.40N	40 cm long	40	0,5	0,95
4348.45N	45 cm long	45	0,75	1
4348.50N	50 cm long	50	1,25	1,2
4348.01N	55 cm long	55	1,7	1,35

The throw-away piping bags have the same use as the nylon ones but without the inconvenience of cleaning and upkeep. Reinforced edges. T° 70°C max.
Roll in a dispenser box.

Dispenser box of 100 disposable pastry bags - Polyethylene



Code	Designation	Lcm	Kg
4346.45N		45	1

The throw-away piping bags have the same use as the nylon ones but without the inconvenience of cleaning and upkeep. Reinforced edges. They are made of transparent polypropylene. Their hygiene is perfect. They are also very practical in their dispenser box. 90 microns.

Set of 8 plastic clips TWIXIT to close pastry bags



Code	Designation	Kg
4336.00	3 different sizes : L. 13 / 10 / 5 cm	0,1

Holder for pastry bag, polypropylene



Code	Designation	Øcm	Hcm	Kg
4347.10N		19,5	23	0,12

This pastry bag holder is made of food plastic and enables one to maintain the full pastry bag straight, ready to use.

Stainless steel horn core



Code	Designation	Øcm	Lcm	Th.mm	Kg
3006.25		2,5	9	0,3	0,01
3006.30		3	12	0,3	0,01
3006.35		3,5	14	0,3	0,02

This conical mould lets you make puff-pastry horns of plenty.

Stainless steel tube



Code	Designation	Øcm	Lcm	Kg	PU
3000.04	Champagne Cork/Mushroom, individual	4	4	0,06	5
3005.02	Cheese Roulé, individual	2,1	10	0,05	5

These stainless steel tubes are especially robust (1.5mm / 16 gauge thick) and easy to keep clean. They help you make catering products (cheese rolls, mini-soufflés, etc.).

Stainless steel pastry-roll core



Code	Designation	Øcm	Lcm	Th.mm	Kg
3007.25		2,5	10	0,3	0,01

This tool lets you make puff pastry rolls which can then be filled with sweet or savory mixtures.

Punch bottle



Code	Designation	Øcm	Hcm	Liters.	Kg
044085N	Punch bottle with plug	8	29	1	0,11

Made from food-grade plastic, the punch doser has a perforated cap for soaking biscuits.

Pastry brushes with wooden handle - Natural bristles



Code	Designation	Lcm	Wcm	Kg
4805.01N	Set of 2 pastry brushes l.30 mm	23	3	0,4
4805.02N	Set of 2 pastry brushes l.40 mm	24	4	0,6

The pastry brush is used for glazing yeast dough or for coating desserts. It can also be used to moisten the walls of a sugar saucepan.



Silicone brush



Code	Designation	Lcm	Wcm	Kg
4807.00N		19,5	3	0,02
4807.25N		25	3	0,04
4807.50N		25	6	0,05

Hygienic brush. Easily cleanable. T° resistance until 250°C.

Large silicone pastry brush



Code	Designation	Lcm	Wcm	Hcm	Kg
4807.60N	fine silk	25	4	3	0,07

A wider and thicker brush: more preparation (butter, egg yolk...) is taken once and the finest silk allows a more regular brushing without traces. Temperature resistance until 250°C.

Kitchen blowtorch



Code	Designation	Hcm	Kg
2040.00N	Delivered empty	15,7	0,17

An absolute must for caramelizing Catalan creams, flans, meringue tarts, or apple tarts, melting cheese, browning meats, peeling tomatoes, and even for paint stripping! Easy and safe to use with its automatic

piezoelectric ignition button and adjustable flame. For use with Butane gas (lighter gas). Easy-to-fill tank.

St. steel caramelizing iron



Code	Designation	Kg
3052.15	With bowlamp "Soudogaz X2000" (No smoke, no smell)	1,1
3052.16	Iron alone for X2000	0,5
	While stocks last	

The caramelizing iron is a stainless steel fitting that goes on the portable Soudogaz blowtorch and protects the mixture from the flame. If you use a naked flame on crème brûlées, Italian meringue, etc., to caramelize them, this is toxic and gives a burnt taste to the

food instead of a caramel flavour. This iron is sturdy, space-saving compared with an electric iron.





FLEXIBLE MOULDS

The De Buyer patented silicone Elastomoule moulds
are the flexible moulds chosen by the professionals.
They can be used for anything: warm, cold, frozen, sweet or savoury.

-228 -
ELASTOMOULE

-233 -
MOUL'FLEX PRO

-235 -
MOUL'FLEX



ELASTOMOULE

1 recipe card supplied with each mould :
 6 MOF and/or World Champions in Pastry
 realize their original pastry recipe
 in the De Buyer's Elastomoule moulds.
 Made in France ORIGINE FRANCE GARANTIE

ELASTOMOULE

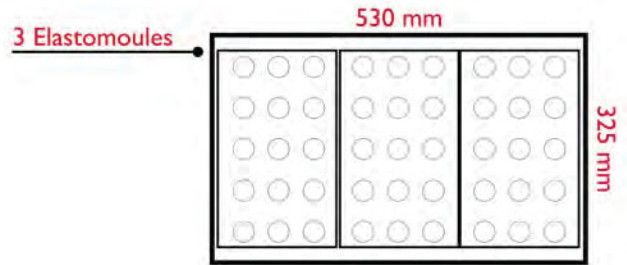
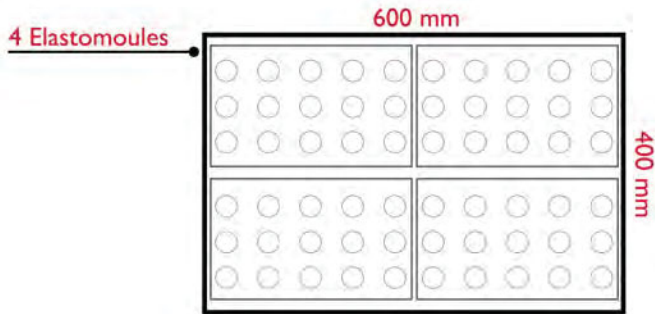

Elastomoule - 40 mini-cylinders ø 27,5 mm



Code	Designation	Øcm	Hcm	Kg
1873.01	300 x 176 mm 1,4 cl	2,75	2,5	0,26

Silicone moulds ELASTOMOULE - Mini-hemispherical - 1,2 cl



Code	Designation	Øcm	Hcm	Kg
1850.01	29 x 19,3 cm - 24 cakes	3	1,8	0,11
1850.21	21 x 17,6 cm - 20 cakes	3	1,8	0,1

Silicone foam mould. Non-stick. For cooking in the oven and freezing, from -70°C to 300°C (-90°F to 580°F). Perfect heat transmission, thereby gaining time and allowing juices to caramelize. The mini hemispheres are perfect for making chocolates, dainties, fruit paste sweets.

Elastomoule - 20 MINI Cakes



Code	Designation	Lcm	Wcm	Hcm	Kg
1868.01	Tray 300 x 176 mm 3,15 cl	5	2,7	2,7	0,26



Silicone moulds ELASTOMOULE - 48 Mini-hemispheres with flat bottom - ø 25 mm

Code	Designation	Øcm	Hcm	Kg
1866.01	300 x 176 mm 4 cl	2,5	1	0,15



Silicone moulds ELASTOMOULE - Financier - 4,2 cl

Code	Designation	Lcm	Wcm	Hcm	Kg
1875.21	21 x 17,6 cm - 6 cakes	9,5	4,4	1,2	0,1



Silicone foam mould. Non-stick. For cooking in the oven and freezing, from -70°C to 300°C (-90°F to 580°F). The Elastomoule material transmits heat perfectly and gives a lovely golden appearance to the top and underneath of products while giving them a succulent taste thanks to the caramelization of juices. The mould has sharp angles for a nice appearance.

Silicone moulds ELASTOMOULE - Mini-financier - 1,05 cl

Code	Designation	Lcm	Wcm	Hcm	Kg
1852.01D	1,05 cl 30 x 20 cm - 25 cakes	4,9	2,6	1,1	0,14
1852.21D	21 x 17,6 cm - 15 cakes	4,9	2,6	3	0,1



Silicone foam mould. Non-stick. For cooking in the oven and freezing, from -70°C to 300°C (-90°F to 580°F). The Elastomoule material transmits heat perfectly and gives a lovely golden appearance to the top and underneath of products while giving

them a succulent taste thanks to the caramelization of juices. The mould has sharp angles for a nice appearance.

Silicone moulds ELASTOMOULE - Mini-Muffins ø 45 / 38 mm - 3,9 cl

Code	Designation	Øcm	Lcm	Wcm	Hcm	Kg
1858.01D	30 x 20 cm - 15 cakes 3,9 cl	4,5	30	17,6	3	0,24
1858.21D	21 x 17,5 cm - 9 cakes	4,5	21	17,6	3	0,17



Silicone foam mould. Non-stick. For cooking in the oven and freezing, from -70°C to 300°C (-90°F to 580°F). The Elastomoule material transmits heat perfectly and gives a lovely golden

appearance to the top and underneath of products while giving them a succulent taste thanks to the caramelization of juices. The mould has sharp angles for a nice appearance.



Silicone moulds ELASTOMOULE - Round mini-tartlet

Code	Designation	Øcm	Hcm	Kg
	ø 45 mm- 0,95 cl			
1853.01D	30 x 20 cm - 24 cakes	4,5	1,1	0,15
1853.21D	21 x 17,6 cm - 12 cakes	45	1,1	0,1
	ø 50 mm - 1,9 cl			
1859.01D	30 x 20 cm - 15 cakes	5	1,5	0,14

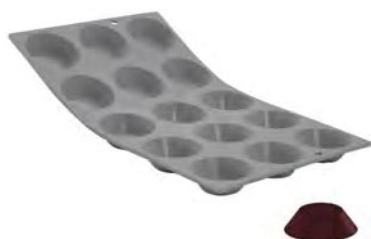

Silicone foam mould. Non-stick. For cooking in the oven and freezing, from -70°C to 300°C (-90°F to 580°F). Perfect heat transmission, thereby gaining time and allowing juices to caramelize. Elastomoule mini jam tart moulds are perfect for making sweet or savory catering products.

Silicone moulds ELASTOMOULE - Mini-Muffins 'Pomponnette' ø 46/30 mm

Code	Designation	Øcm	Lcm	Wcm	Hcm	Kg
1862.21	23,5 x 17,6 cm - 12 cakes	4,6	23,5	17,6	2,4	0,13

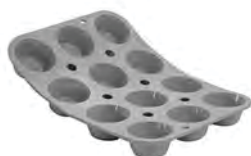

Silicone moulds ELASTOMOULE - Mini-madeleine - 0,64 cl

Code	Designation	Lcm	Wcm	Hcm	Kg
1851.01D	30 x 20 cm - 30 cakes	4	3	1,1	0,13
1851.21D	21 x 17,6 cm - 20 cakes	4	3	1,1	0,1

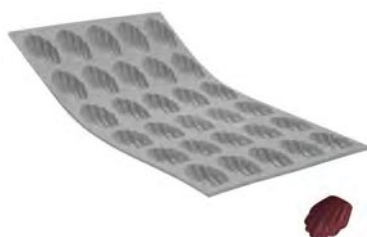

Silicone foam mould. Non-stick. For cooking in the oven and freezing, from -70°C to 300°C (-90°F to 580°F). The Elastomoule material transmits heat perfectly and gives a lovely golden

appearance to the top and underneath of mini Madeleine cakes while giving them a succulent taste thanks to the caramelization of juices that takes place in these moulds.

Silicone moulds Elastomoule - 8 small Brioches

Code	Designation	Øcm	Hcm	Kg
1845.01	30 x 17,6 cm - 8 cakes ø 60/31 mm 4,2 cl	6	2,8	0,16





Elastomoule - 40 mini-cubes 25 mm

Code	Designation	Lcm	Wcm	Hcm	Kg
1869.01	300 x 176 mm 1,5 cl	2,5	2,5	2,5	0,25



Silicone moulds ELASTOMOULE - Mini-"Bordelais" fluted cake - 1,9 cl

Code	Designation	Øcm	Lcm	Wcm	Hcm	Kg
1856.01D	30 x 17,6 cm, 28 cakes - R'SYSTEM 1,9 cl	3,5	30	17,6	3,5	0,31
1856.21D	21 x 17,5 cm - 20 cakes 1,9 cl	3,5	21	17,6	3,5	0,22



The Elastomoule mini Bordelais R'SYSTEM is a BRAND NEW mould. Localized perforations between the indentations give improved heat convection across the whole plate, resulting in perfect baking.

Silicone moulds ELASTOMOULE - PORTIONS "Bordelais" fluted cake - 8,2 cl

Code	Designation	Øcm	Hcm	Kg
1834.01D	30 x 20 cm - 8 cakes 8,2 cl	5,5	5	0,3
1834.21D	21 x 17,6 cm - 6 cakes	5,5	5	0,17



Silicone foam mould. Non-stick. For cooking in the oven and freezing, from -70°C to 300°C (-90°F to 580°F). Perfect heat transmission, thereby gaining time and allowing juices to caramelize. The "Bordelais" Elastomoule Portions give the same cooking quality and savors as the famous copper molds used for crunchy Bordeaux Cannelé cakes.

ELASTOMOULE -PORTIONS Madeleine - 3 cl

Code	Designation	Lcm	Wcm	Hcm	Kg
1832.01D	30 x 20 cm - 9 cakes 3 cl	8	4,5	1,7	0,14
1832.21D	21 x 17,6 cm - 8 cakes	8	4,5	1,8	0,1

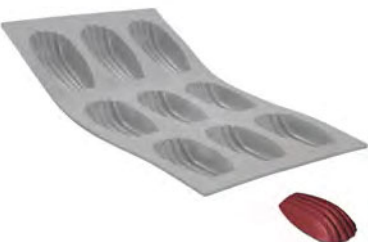

Silicone foam mould. Non-stick. For cooking in the oven and freezing, from -70°C to 300°C (-90°F to 580°F). The Elastomoule material transmits heat perfectly and gives a lovely golden appearance to the top and underneath of Madeleine cakes while giving them a matchless taste thanks to the caramelization of juices that takes place in these moulds.

ELASTOMOULE - PORTIONS Cake - 10,5 cl



Code	Designation	Lcm	Wcm	Hcm	Kg
1831.01D	30 x 20 cm - 9 cakes 10,5 cl	9	4,8	3	0,26
1831.21D	21 x 17,5 cm - 6 cakes	9	4,8	3	0,11

Silicone foam mould. Non-stick. For cooking in the oven and freezing, from -70°C to 300°C (-90°F to 580°F). The CAKE Elastomoule is made from a material that transmits heat perfectly

and gives a lovely golden appearance to the top and underneath of cakes, fruit cakes, and breadrolls while giving them a succulent taste thanks to the caramelization of juices.

Silicone moulds ELASTOMOULE - PORTIONS Muffins ø 74 / 54 mm - 9,5 cl



Code	Designation	Øcm	Lcm	Wcm	Hcm	Kg
1833.01D	30 x 20 cm - 6 cakes 9,5 cl	7,4	30	17,6	3	0,16
1833.21D	21 x 17,6 cm - 4 cakes	7,4	21	17,6	3	0,11

Silicone foam mould. Non-stick. For cooking in the oven and freezing, from -70°C to 300°C (-90°F to 580°F). The Elastomoule material transmits heat perfectly and gives a lovely golden

appearance to the top and underneath of products while giving them a succulent taste thanks to the caramelization of juices. The mould has sharp angles for a nice appearance.

ELASTOMOULE CUBE

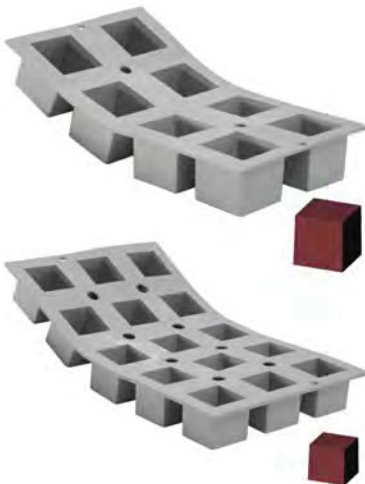

Code	Designation	Lcm	Wcm	Hcm	Kg
1836.01	cube portions - 8 cakes 11,5 cl.	5	5	5	0,34
1861.01	minicubes mould - 15 cakes 4 cl.	3,5	3,5	3,5	0,28

The cubic revolution is taking hold in the kitchen, bringing original creations to your plates and shapely formations to your platters. The cube portion mould makes individual preparations, and the mini-cube mould prepares pastries the perfect size to pop in your mouth. Finger food and delicacies at the same time. The Elastocube has been carefully designed to guarantee flawless shapes with straight lines and geometric angles. It is suitable for both hot and cold use, and will successfully fulfill any and all of your demands

Silicone mat ELASTOMOULE, smooth relief (10 mm high)



Code	Designation	Lcm	Wcm	Hcm	Kg
1800.55		55,5	36	1	0,3

Patterned silicone foam tray. Non-stick. For cooking in the oven and freezing, from -70°C to 300°C (-90°F to 580°F). Perfect heat transmission, thereby gaining time and allowing juices to caramelize. The plain tray is perfect for making caramels, fruit paste, etc., which are then cut up using a banjo-wire guillotine.

Moul'flex Pro



Silicone nonstick supple professional moulds

- Foodgrade PLATINUM silicone without peroxide guaranteed. For intensive use
- Professional dimensions 400 x 600 mm or GN 1/1.
- For oven cooking and freezing from -40°C/-40°F to +300°C/580°F
- Reduction in cooking time thanks to the R'System® perforations. Perforations localized between the various imprints of the plate for a better heat or cold convection and to obtain: Patented system

Silicone moulds MOUL'FLEX PRO - Hemispherical molds



Code	Designation	Øcm	Hcm	Kg
1704.60	Tray 600 x 400 mm - 28 cakes 8,4 cl	7	3,5	0,67
1704.53	Tray gastro GN 1/1 - 18 cakes	7	3,5	0,4

Silicone moulds - MOUL'FLEX PRO - mini cakes



Code	Designation	Lcm	Wcm	Hcm	Kg
1701.53	Tray Gastro GN 1/1 - 20 cakes 10,5 cl	9,7	4,8	3	0,5
1701.60	Tray 600 x 400 - 30 cakes While stocks last	9,7	4,8	3	0,75

Silicone moulds MOUL'FLEX PRO - portions "Madeleine"



Code	Designation	Lcm	Wcm	Hcm	Kg
1707.60	Tray 600 x 400 mm - 44 cakes 3 cl	7,57	4,2	1,8	0,68

Silicone moulds MOUL'FLEX PRO - portions muffins

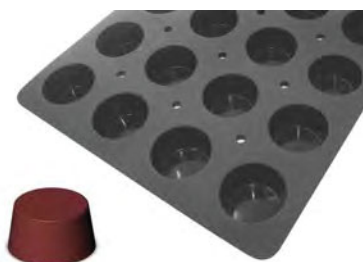

Code	Designation	Øcm	Hcm	Kg
1710.60	Tray 600 x 400 mm - 24 cakes 12,2 cl	6,8	3,5	0,74
1710.53	Tray gastro GN 1/1 - 24 cakes	6,8	3,5	0,54

Silicone moulds MOUL'FLEX PRO - portions "Bordelais" fluted cakes

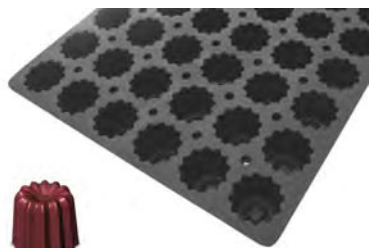

Code	Designation	Øcm	Hcm	Kg
1708.60	Tray 600 x 400 mm - 54 cakes	5,5	4,7	1
	8,2 cl			
	While stocks last			

Silicone moulds MOUL'FLEX PRO - mini-tartlets

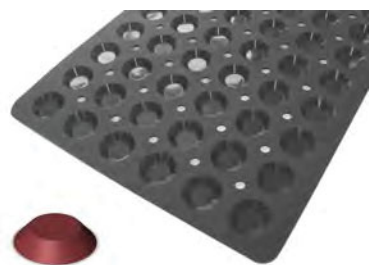

Code	Designation	Øcm	Hcm	Kg
1711.60	Tray 600 x 400 mm - 60 cakes	4,1	0,8	0,58
	0,95 cl			
	While stocks last			



FLEXIBLE NONSTICK MOULDS
 Foodgrade PLATINUM SILICONE
 guaranteed without peroxyde
 -40° to + 280°C (-40° / 530°F)

*Ideal for SWEET and SAVORY HOT,
 COOL or FROZEN PREPARATIONS*

MOUL'FLEX - 7 rectangular "Financier" cakes

Code	Designation	Lcm	Wcm	Hcm	Kg
1976.03	Black tray 295 x 173 mm	9,5	4,5	1,2	0,09



MOUL'FLEX - 25 moulds Mini-Financiers

Code	Designation	Lcm	Wcm	Kg
1976.02	Tray 17,5x30 cm 1,05 cl	4,9	2,6	0,15



MOUL'FLEX- Silicone moulds - Mini-"Bordelais" fluted cakes

Code	Designation	Øcm	Hcm	Kg
1977.01	BLACK tray 17,5 x 30 cm - 28 "Bordelais" cake 1,9 cl	3,5	3,5	0,21



MOUL'FLEX- Silicone moulds - 8 Bordelais fluted cakes

Code	Designation	Øcm	Hcm	Kg
1968.01	tray 17,5x30 cm 8,2 cl	5,5	5	0,16

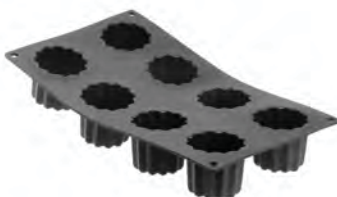

MOUL'FLEX - 8 big cones



Code	Designation	Øcm	Hcm	Kg
1997.01	Black tray 17,5 x 30 cm 9,2 cl While stocks last	5,1	5,9	0,13

MOUL'FLEX - 15 Silicone moulds - Hemispherical ø 4 cm



Code	Designation	Øcm	Hcm	Kg
1961.02	tray 17,5x30 cm 2 cl	4	2	0,1



MOUL'FLEX- Silicone moulds - Hemispherical ø 7 cm



Code	Designation	Øcm	Hcm	Kg
1961.01	BLACK 17,5x30 cm - 6 hemispherical moulds 8,9 cl	7	3,4	0,1

The MOUL'FLEX range of flexible silicone moulds offers you a wide choice of baking plates and large individual moulds for making sweet, savory, hot, cold, and frozen preparations.

MOUL'FLEX- Silicone moulds - 6 Muffins



Code	Designation	Øcm	Hcm	Kg
1962.01	tray 17,5x30cm 9,7 cl	7,2	3	0,11

MOUL'FLEX is as good for baking as it is for freezing and turns out to be ideal for bain-marie cooking. The silicone is non-stick: there's no need to grease the moulds, and turning out and cleaning are extremely easy.



MOUL'FLEX- Silicone moulds - Small fluted brioches



Code	Designation	Øcm	Hcm	Kg
1964.01	BLACK tray 17,5 x 30 cm - 6 small brioches 9,5 cl	8	3,5	0,11

Before first use: - Wash the MOUL'FLEX in soapy water or in the dishwasher - Grease the mould the first time you use it with a little oil or melted butter. For subsequent use, you don't need to grease the mould any more.

MOUL'FLEX- Silicone moulds - Mini round tartlets ø 5 cm



Code	Designation	Øcm	Hcm	Kg
1975.01	BLACK tray 17,5 x 30 cm - 15 round tartlets 1,9 cl	5	1,5	0,1

MOUL'FLEX- Silicone moulds - Madeleines



Code	Designation	Lcm	Wcm	Hcm	Kg
1966.01	BLACK tray 17,5 x 30 cm - 9 madeleines 3 cl	7,5	4,5	1,8	0,1

- For use in a heat-circulating oven, place the grille at mid-height in the oven. - For use in a traditional oven, place it near the bottom of the oven instead.

MOUL'FLEX - Silicone moulds - Mini-Madeleine



Code	Designation	Lcm	Wcm	Hcm	Kg
1994.01	Black tray - 17,5 x 30 cm - 30 cakes 0,63 cl	4	3	1,1	0,09

MOUL'FLEX- Silicone moulds - Savarin



Code	Designation	Øcm	Hcm	Kg
1963.01	tray 17,5 x 30 cm - 6 Savarin moulds 7 cl	7,2	2,3	0,14
	While stocks last			

For making everything from attractive rum babas and jelly crowns to fish pâté.

MOUL'FLEX- Silicone moulds - Rectangular mould Cake



Code	Designation	Lcm	Wcm	Hcm	Kg
1976.01	BLACK tray 17,5 x 30 cm - 9 Cake moulds 9 cl	9	4,8	3	0,19

MOUL'FLEX- 8 silicone moulds - Oval



Code	Designation	Lcm	Wcm	Hcm	Kg
1971.01	Tray 17,5x30 cm 9,7 cl While stocks last	6,5	4,1	3,4	0,16

MOUL'FLEX - Silicone mould - Rectangular mould CAKE



Code	Designation	Lcm	Wcm	Hcm	Liters.	Kg
1984.24	BLACK	24	10,5	6,5	1,4	0,16

This mould can be used for making sweet or savory cakes, pâtés, etc.

MOUL'FLEX - Round pie pan



Code	Designation	Øcm	Hcm	Liters.	Kg
1990.24		24	4,2	1,9	0,17

MOUL FLEX - Tower



Code	Designation	Lcm	Wcm	Hcm	Kg
1989.00		26,4	16	5	0,16

MOUL'FLEX - Set of 6 silicone round muffin moulds "CUP CAKE"



Code	Designation	Kg
1985.05	ø 5 cm While stocks last	0,03

MOUL FLEX quality - Pure platinum silicone - peroxyde free. For freezing and oven cooking (traditional oven and microwaves). Perfect for muffins, savory or sweet cakes, pannacottas, chocolate cakes, custards,... Packed in a PVC transparent box.



DE BUYER INDUSTRIES TERMS AND CONDITIONS OF SALE - 2021 version

«These terms and conditions of sale apply to all sales made by our company and cannot be cancelled or unilaterally amended regardless of the clauses set forth in the buyer's documents, and in particular their terms and conditions of purchase, over which these terms and conditions of sale take precedence and constitute the basis for negotiations in accordance with the provisions of Article L. 441-6 of the French Commercial Code.»

1- DOCUMENTS

All texts, information, characteristics or photographic reproductions included in our prices, catalogues or documentation are for information purposes only and are not guaranteed. We cannot, under any circumstances, be held liable in this respect in the event of inaccuracies. We reserve the right to make modifications thereto without giving prior notice.

2 - ORDERS

Orders are only considered definitive when they have been confirmed in writing. In the event of a stock shortage, DE BUYER will process orders based on their order of arrival and while stocks last.

Any amendment to or cancellation of an order for products from the catalogue, requested by the client, can only be considered if made in writing at least five (5) working days before the dispatch of catalogue products.

DE BUYER reserves the right to make any amendments to its products, that it deems useful, at any time and to amend the models defined in its prospectuses or catalogues without giving prior notice.

3- PRICES

The prices applicable to the buyer are specified in Euros, excluding taxes, including packaging, except for special packaging charged separately, net and not including transport.

The prices are non-binding and can be modified at any time without notice. Invoices are drawn up based on the prices in force on the order confirmation date.

4- DISCOUNTS

The client may benefit from a discount depending on the quantities purchased or delivered at one time or to one location, or based on the frequency of orders.

5 - SUPPLY, ONLINE SALES

Products for online distribution must be exclusively supplied by the manufacturing company. The purpose of online distribution is to market Products to the end customer or authorised distributors which are part of the company's selective distribution network.

Consequently, the buyer expressly undertakes not to sell Products to unauthorised retailers, wholesalers or traders, an essential undertaking in this agreement without which the parties would not have entered into a contract.

The marketing of Products by means of a website is subject to a Selective Distribution Agreement.

The Selective Distribution Agreement or refusal to grant an authorisation will be communicated to the buyer within thirty (30) days of receipt of the full authorisation application file.

The authorisation to sell Products through a website is granted to the buyer for a period of one (1) year as from the signature of the Agreement and will be automatically updated for a further period of one (1) year, unless terminated by one of the parties, respecting a notice period of three (3) months.

In the event of a breach of one of the obligations under the Agreement, by the buyer, on the website, and if the buyer does not remedy such breaches within a period of one (1) month as from formal notice given by the company by registered letter with acknowledgement of receipt asking that the situation be rectified, the agreement will be automatically terminated.

By distributing online, the buyer undertakes to take proper care of the sale of the Products online and to comply with the legal requirements, in particular:

- To only retail the Products to the end user and only process normal requests from this category of buyer;
 - Permanently have sufficient stock, stored in conditions which make it possible to meet consumer requests for Products, and otherwise to remove the Products from its offer in the absence of stock allowing it to meet demands, the storage conditions being defined in the authorisation;
 - Deliver products to consumers based on available stock, limited to two (2) units of the same reference per order;
 - Inform the client of the usual delivery times, which should not exceed eight (8) working days as from the placing of the order online, and the existence of a right of withdrawal;
 - Indicate the payment, delivery and performance methods as well as the validity of the offer and the price.
- By distributing online, the buyer undertakes to respect legislation specific to online sales and general applicable regulations. It undertakes to make transparent offers to the consumer, provide advice and assistance and an aftersales service.

6- REGULATIONS

- Applicable for France:

Our invoices are payable within thirty (30) days of the invoice issue date, net, without any discount. For cash payments, i.e. received within a maximum of ten (10) days from the invoice date, the client can deduct a discount of zero point five percent (0.50%). Beyond outstanding invoices authorised by us, and which can be modified at any time, our invoices are payable in advance.

- Applicable for Exports:

The first orders are payable in advance. Any other payment method can only be used after providing the commercial references and bank details, and remains subject to approval of our insurance company. Our invoices are then payable within thirty (30) days of the invoice issue date, net, without any discount. Any tax, charge, duty or other service payable in accordance with French regulations, or those of an import company or transit company, are payable by the client.

- Applicable for France and Exports:

For orders involving a special manufacture, made off plan, one third (1/3) of the amount will be payable in advance as a down payment.

In the event of failure to respect a deadline or late payment, all amounts due are immediately payable and all pending orders will be suspended.

Moreover, in light of the terms of Article L. 441-10 of the French Commercial Code, the buyer is automatically required to pay penalties calculated on the amounts due by applying a rate corresponding to three (3) times the legal interest rate in force on the due date, increased by 10%. By virtue of Article L. 441-10 paragraph 5 of the Commercial Code and in accordance with Article D. 441-5 of the French Commercial Code, a lump-sum indemnity for collection costs of forty (40) euros is automatically payable by the buyer from the first day of delay. If the collection costs incurred are higher, an additional indemnity may be requested by the company upon presentation of supporting documents.

If, following a particular agreement, the payment date mentioned on the invoice is after the deadline indicated in the terms and conditions of sale, the date mentioned on the invoice will be taken into account.

All of the above-mentioned conditions are understood under the guarantees granted by insurance companies.

In the event of non-payment, forty-eight (48) hours after formal notice sent by registered letter with return receipt requested remaining without response, the sale will be automatically cancelled if we so choose and we may request, in summary proceedings, the return of the products, without prejudice to any other damages. The cancellation will concern not only the order in question, but also all previous unpaid orders, whether they have been delivered or are out for delivery and their payment is due or not.

In the case of payment by paper instrument, failure to return the instrument within the legal time frame will be considered as non-acceptance equivalent to non-payment. Any client credit deterioration may justify the demand for guarantees or an advance payment, before completion of the orders received. Payments cannot, under any circumstances, be suspended or be the subject of any compensation without the prior written consent of DE BUYER.

7- CARRIAGE AND PACKAGING, INSURANCE, DELIVERY

Even for dispatches postage paid, merchandise is always sent at the buyer's risk and peril and it is its responsibility to verify merchandise upon arrival, and if applicable to seek remedy, by registered letter with return receipt requested, from the carriers, who alone are liable for damage, theft, losses or delays.

The buyer is required in particular to verify the visible condition of merchandise upon delivery. With regards to losses or damage observed, the buyer must send any claims to the carrier in accordance with Articles L. 133-3 and following of the Commercial Code, by registered letter with return receipt requested, within 3 days of delivery, with a copy sent to DE BUYER. No claim can be validly accepted in the event that the buyer fails to respect these formalities.

Our delivery times are given for information purposes only and run as from when the order is considered firm and definitive. DE BUYER undertakes to respect said times. Delays cannot under any circumstances justify full or partial cancellation of the order or give the client a right of retention or entitle it to the payment of damages.

DE BUYER will not, under any circumstances, be liable to pay direct or indirect damages, of any kind whatsoever, arising due to failure to respect delivery deadlines.

The risks of loss or deterioration of the products and any risk of liability related to the existence or use of products are transferred to the client as from dispatch. The client therefore undertakes to take out insurance to cover products against any risk, in particular fire, theft or water damage.

In the absence of specific dispatch instructions from the client, DE BUYER can have products transported by the carrier of its choice without it being possible for it to be held liable.

Moreover, in the event of interruption of work due to force majeure, as defined hereafter, contracts will be suspended and we cannot be held liable.

8- CLAIMS AND RETURN OF MERCHANDISE

We do not accept any automatic returns. Returns of merchandise are only authorised after written acceptance by us and will be sent postage paid. Merchandise must have been delivered within the last twenty (20) working days to be eligible. They will give rise, after analysis by and decision of our quality department, to the replacement of any product recognised as defective by DE BUYER or a credit note which will be issued based on the net price invoiced.

For any return of merchandise due to an error by the client regarding the quantity ordered, the code (as proven by the reference number mentioned on the order), we will apply a thirty percent (30%) discount to the value of the returned merchandise purchase value for restocking costs and shipping costs paid by DE BUYER for dispatch of the merchandise, after quantitative and qualitative verification of the products.

Restrictions: the following items are not eligible for returns regardless of the circumstances:
- Products damaged, used or stored in unfavourable conditions, or used in an abnormal or inappropriate manner;
- Special manufactures or orders and products not included in the catalogue.

Any claim must be made by registered letter with acknowledgement of receipt requested within a maximum of eight (8) working days as from the delivery date.

In the event of a claim regarding articles, our liability is limited to replacing the defective piece or article, without it being necessary, under any circumstances or for any reason whatsoever to grant an indemnity of any kind. Shipping costs for pieces or articles and the return of defective pieces or articles are borne by the buyer.

9- CONDITIONS FOR USE OF THE BRANDS AND ADVERTISING MEDIA

The company owns all intellectual and industrial property rights covering products sold under its brand and/or any other brand used by the company. Commercial relations established between the company and the buyer do not give the buyer any right over advertising media, brands or any other distinctive company sign. Any use of these elements by the buyer requires the company's prior written consent.

Use by the buyer of these advertising media, brands and distinctive signs on commercial documents, in particular advertisements, catalogues, prospectuses, professional directories etc. is subject to DE BUYER's express prior consent.

In the event of wrongdoing by the buyer in the reproduction or use of one of these elements, DE BUYER will be entitled to claim compensation for the harm suffered.

The buyer undertakes not to carry out promotional campaigns (sales, discounts, promotions etc.) on products supplied under the DE BUYER brand without the express prior consent of the latter. Any sale of counterfeit merchandise and/or merchandise resembling DE BUYER's merchandise (product itself, packaging, brand, logos etc.) which may lead to confusion in the minds of the public is prohibited.

DE BUYER reserves the right to change the technical properties of products supplied without informing the buyer beforehand. Failure to respect the provisions above can result, if DE BUYER chooses, in the suspension of deliveries, reconsideration of the agreement and/or compensation for harm suffered.

10- MANUFACTURING WARRANTY

The products are covered by a one (1) year warranty as from the delivery date.

- It applies to products used in normal and suitable conditions and for which a manufacturing defect is observed by our Quality department;

- It does not apply to damaged products or products used or stored in unfavourable conditions, or used in an abnormal, inappropriate manner, or special manufactures;

- It does not apply in the case of apparent defects.

In order to assert its rights, the buyer must inform DE BUYER, in writing of the existence of defects within a period of one (1) year as from the date on which the defect is observed, under penalty of losing the right to take any related actions.

DE BUYER will replace or repair those products or pieces under warranty deemed defective by the quality department. The replacement of defective products or pieces will not give rise to an extension of the warranty specified above.

The buyer alone is liable for patents and counterfeits with respect to special articles made based on models or designs provided by the buyer.

Keen to improve quality, we reserve the right to make any changes to our articles which we deem necessary.

11- PENALTY CLAUSE

The buyer undertakes to pay, under the penalty clause, in accordance with Article 1231-5 of the French Civil Code, a lump-sum indemnity of fifteen percent (15%) excluding taxes of the agreement, in the event that it does not perform one of its obligations. The penalty is indivisible and payable to DE BUYER, even if the latter requests the cancellation of the agreement. This clause does not prevent DE BUYER from taking legal action to obtain compensation for all harm suffered due to non-performance if said harm exceeds the amount of the penalty clause.

12- TITLE RETENTION

In the event of non-payment by the client of all or part of the price of the order, DE BUYER reserves, until payment in full, a property right over the products sold, allowing it to take back possession of said products. Any down-payment made by the client will remain the property of DE BUYER as a lump-sum indemnity, without prejudice to any other actions it may be entitled to bring against the client in this respect. Consequently, the transfer of ownership of the products, to the benefit of the buyer, will only take place upon full payment of the price by the latter, regardless of the delivery date of said products.

13- FORCE MAJEURE

The company is automatically released from its obligations if the payment conditions are not respected by the buyer or in the event of force majeure or events such as: industrial action, complete or partial strikes in the company or of its suppliers, service providers, carriers, postal services, public services, unavailability of raw materials or power, urgent injunction of public authorities (import ban, embargo), operating accidents, machine breakdown, explosion, epidemic, war, armed conflict, attack, earthquake, requisition, fire, flood, machinery accidents, falling or shortcoming of a supplier or subcontractor. The company will inform the buyer informed, at the earliest opportunity of force majeure events.

14- PERSONAL DATA PROCESSING

DE BUYER, data controller, processes the data of employees and/or client partners in the context of commercial relations with clients whose purpose is the negotiation, completion, management, tracking, preparation and dispatch of orders, invoicing, accounting, and collection as well as the sending of commercial and/or advertising information.

Pursuant to the conditions defined in the French Data Protection Act and the European General Data Protection Regulation (or GDPR), data subjects are entitled to access, request rectification, erasure, minimisation and, as may be relevant, portability of personal data.

Data subjects are also entitled to define general and specific directives specifying the way in which they expect the rights mentioned above to be exercised after their death.

Pursuant to the conditions provided for by law and the GDPR, if the legal basis of processing is in the legitimate interest of the company, unless the company demonstrates the existence of compelling and legitimate reasons for this processing which prevail over the interests, rights and freedoms of the data subject, subjects can also, for reasons related to their specific situation (legitimate grounds) object to the processing of their personal data.

To exercise these rights or for any other question regarding the processing of personal data, data subjects can contact: info@debuyer.com

Data subjects are entitled to file a claim with the French Data Protection Authority, the Commission Nationale de l'Informatique et des Libertés (CNIL).

For more information, please consult the PERSONAL DATA PROCESSING POLICY available upon request.

15- DISPUTE SETTLEMENT AND JURISDICTION

THE EPINAL (88 France) COMMERCIAL COURT ALONE HAS JURISDICTION, including in the case of a third-party claim or multiple defendants. The only governing law is French law. The French version of these terms and conditions of sale prevails over the English version.

For the payment of our invoices:

Banque CIC F-70 000 VESOU

IBAN : FR76 3008 7331 8200 0212 9910 108
BIC : CMCIFRPP

Bank KOLB SA F-88500 MIRECOURT
IBAN : FR76 1325 9023 2010 2718 0020 048
BIC : KOLBFR21 - SWIFT : NORDFRPP

ALPHABETICAL INDEX

A			
Army mug	33	Frame	178
Alcohol gel	166	Frypan, steel	6-21, 26-28, 77
B		Frypan, nonstick	37-51, 76
Bag (pastry bag)	222, 223	Frypan, stainless steel	57,58,62,66,67,75
Bag holder	223	Frypan, copper	81,85,86,
Bain-marie	70, 71	Frypan «Triblinis»	18
Bain-marie cooker	206	Funnel	141, 207
Baker blade	204	G	
Baking paper	202	Genoise cutter	158
Baking tray	199, 200, 201	Génoise frame	178
Basting spoon	150, 151, 152	Gloves	21, 39, 51, 160, 167
Blini pan	11, 15, 16, 48, 89	Grate	198, 201
Bottle	224	Greaseproof paper	207
Bowl	29, 136	Grip for dish	152
Bucket	139, 140	H-I-J-K	
Burner	28	Hanging bar	149
C		Ice-cream scoop	141
Candy Thermometer	163, 207	Jam pan, copper	95
Caramelizing iron	225	Knife	29, 129, 130, 131, 132
Chestnut fry-pan	27	L	
Chinese strainer	137, 138	Ladle	149, 150, 151, 152
Cleaner for metal	95, 167	LE TUBE	143, 144, 213
Colander	137	Lid	59, 60, 64, 69, 88, 90, 94
Crepe pan, steel	10, 15, 18, 21, 27	Lid, glass	11, 14, 38, 41, 42, 64, 66,
Crepe pan, nonstick	41, 43, 45, 48, 77	Lobster fork	160
Cutter vegetable	125	Long rolled cake mold	172, 173
Cutter	204	M	
Cutting board	133, 166	Meat fork	149
D		Mill	139
Dariole mould	179	Mini saucepan	94
Deep fryer	20	Mould for «Charlotte»	179, 181
Dish	30, 137	Mould for pie	175, 176, 180, 185
Dough scraper	205	Mould, hemispherical	179
Dough wheel	204, 205	Mould, stainless steel	176, 181-185, 224
Dredger	31, 139	Mould Canelés	95, 178
E-F		MOUL'FLEX	235-238
Egg dish	93	MOUL'FLEX PRO	233, 234
Elastomoule	228-232	Mould silicone	228-238
Filter for funnel	141	N	
Fish frypan	46, 47, 59	Nozzles	208-212, 216
Fish kettle	70	Nutmeg mill	107
Flour scoop	140		

O			
Omelette turner	150	Skimmer	149, 150, 151
Oval pan	93	Slicer (vegetable)	116, 117, 118 120, 122, 123, 124
Oven peel	162	Smoker oven	33
Oyster knife	160	Spatula	31, 51, 146, 147 150-158
P		Spices mill	32, 99, 107, 110, 111
Pastry bag	222, 223	Stand for wok	70
Pastry brush	30, 224, 225	Steamcooker	59, 63, 65, 69, 74, 83
Pastry frame	192	Stewpan, nonstick	39
Pastry spatula	157	Stewpan, stainless steel	58, 63, 65, 68
Pepper/salt mill	99-111	Stewpan, copper	83, 85, 87, 91
Piston funnel	144, 145	Stewpan, oval	59, 88
Pizza cutting wheel	32, 161	Stockpot	69, 82, 88, 91
Pizza oven peel	162	Strainer	139
Plancha	16, 19, 25	String	166
Plastic scraper	205	Sugar saucepan	207
Pusher	138, 232	Sweet maker	206
R		T	
Rack for cutting boards	133, 166	Tart mould	161, 180, 181, 185 197, 198
Raplette, sliding & egalizing	193	Tart ring	186-190
Relief sheet	173	Thermometer	163, 164, 165
Ribbon	194	Thermometer with probe	164
Ring for pastry	190-196	Timer	165
Roasting pan	16, 48, 60, 89	Tinned wire basket	20
Rolling pin	204	Tomato-slicer	126
S		Tray	184, 185, 198-201
Salt shaker	106	Tray, round	
Saucepan, nonstick	38	Triangular spatula	31, 158
Saucepan, stainless steel	56, 60, 61, 66, 67, 74	Trivet	28
Saucepan, copper	80, 84, 86, 90, 92	Tweezer	30, 147, 152, 153
Sauté-pan, steel	9, 10, 13	W	
Sauté-pan, nonstick	38, 39, 41, 43, 48	Whisk	155
Sauté-pan, stainless steel	56, 57, 58, 62, 66, 68, 75, 76, 77,	Wok, steel	11, 14, 19
Sauté-pan, copper	80, 81, 82, 84, 85, 87, 90, 92, 93	Wok, nonstick	39, 48
Scales	163	Wok, stainless steel	57, 64, 70
Scharpener	133	Wok, copper	83, 87, 93
Scissors	159		
Self-service dish	33		
Sieve	138		
Silicone mat	202, 203		
Silicone moulds	228-238		
Sirup density meter	163		
Skewer	30, 153		

All texts, information, characteristics and photographs in this catalogue are for information only and are not warranted. We disclaim liability in event of inaccuracy thereof. We reserve the right to make any changes therein without prior notice.

Credits photos : Eric Marin - Bella Karragiannidis
de Buyer Industries - Studio Julien Bouvier - Lézards'Création

Thanks to Atelier TB, Bragard, Febvay France, Garnier-Thiebaut, REVOL.

conditions générales de vente DE BUYER INDUSTRIES - version 2021

«Les présentes conditions générales de vente s'appliquent à toutes les ventes conclues par notre société et ne peuvent être ni annulées, ni modifiées unilatéralement quelles que soient les clauses pouvant figurer sur les documents de l'acheteur, et notamment ses conditions générales d'achat sur lesquelles les présentes conditions générales de vente prévalent et constituent le socle de la négociation conformément aux dispositions de l'article L.441-6 du Code de commerce.»

1- DOCUMENTS

Tous les textes, renseignements, caractéristiques ou reproductions photographiques présents dans nos tarifs, catalogues ou documentations ont une valeur indicative uniquement, sans garantie. Ils ne peuvent en aucun cas engager notre responsabilité en cas d'inexactitude. Nous nous réservons le droit d'y apporter toute modification, sans avis préalable.

2- COMMANDES

Les commandes ne sont définitives que lorsqu'elles ont été confirmées par écrit. En cas de situation de pénurie, la société DE BUYER répondra aux commandes en fonction de leur ordre d'arrivée et dans la mesure de ses disponibilités.

Toute modification ou résolution de commande de produits catalogue demandée par le client ne peut être prise en considération si elle est parvenue par écrit au moins cinq jours ouvrés avant l'expiration des produits catalogue.

La société DE BUYER se réserve le droit d'apporter à tout moment toute modification qu'elle juge utile à ses produits et de modifier sans avis préalable les modèles définis dans ses prospectus ou catalogues.

3- PRIX

Les prix du tarif applicable à l'acheteur s'entendent en Euro, H.T., emballage compris, sauf pour les emballages spéciaux taxés en sus, nets, transport non compris.

Les prix sont donnés sans engagement de notre part et peuvent être modifiés à tout moment sans préavis. La facturation s'effectue selon le tarif en vigueur à la date de confirmation de commande.

4- REMISE

Le client pourra bénéficier de réduction de prix en fonction des quantités acquises ou livrées en une seule fois et un seul lieu, ou de la durée de ses commandes.

5- APPROVISIONNEMENT, COMMERCIALISATION EN LIGNE

La distribution en ligne doit être approvisionnée exclusivement en Produits auprès de la société fabricante. La distribution en ligne a pour but de commercialiser les Produits qu'un consommateur final ou à des distributeurs agréés membres du réseau de distribution s'lectif de la société.

L'acheteur s'interdit expressément en conséquence de vendre les Produits à des revendeurs non agréés, grossistes ou négociants, obligation essentielle du contrat sans laquelle les parties n'auraient pas contracté.

La commercialisation des Produits au moyen d'un site Internet est soumise à un Contrat de distribution sélective.

Le Contrat de distribution sélective du site Internet ou le refus d'agrément sera communiqué à l'acheteur dans un délai de trente jours ouvrés suivant la réception d'un dossier complet de demande d'agrément.

L'agrément pour la vente des Produits par l'intermédiaire d'un site Internet est accordé à l'acheteur pour une durée d'un (1) an à compter de la signature du Contrat et se renouvellera par tacite reconduction pour une nouvelle période d'un (1) an, sauf d'nonciation préalable par l'une ou l'autre des parties, moyennant le respect d'un préavis de trois mois.

En cas de manquement de l'acheteur sur le site en ligne à l'une des quelconques obligations lui incombant au titre du Contrat, et s'il ne met pas fin aux dits manquements dans un délai d'un (1) mois suivant une lettre de mise en demeure de la société par courrier recommandé avec accusé de réception lui demandant d'y remédier, le contrat sera résilié de plein droit. L'acheteur en distribuant en ligne s'engage à apporter les meilleurs soins à la vente des Produits sur Internet, à se conformer aux exigences légales et notamment à :

- Ne vendre les Produits qu'au consommateur final au détail, et à ne répondre qu'à des demandes normales de cette catégorie d'acheteur ;

- Disposer en permanence d'un stock suffisant conservé dans des conditions adaptées pour faire face aux demandes de Produits des consommateurs, et à défaut retirer les Produits de l'offre en l'absence de stocks permettant de répondre à la demande, les conditions de stock étant définies dans l'agrément ;

- Livrer les consommateurs en fonction des stocks disponibles dans la limite de deux (2) unités d'une même référence par commande ;

- Indiquer les délais habituels de livraison au client, qui ne doivent pas excéder huit (8) jours ouvrés à compter de la commande par Internet, ainsi que l'existence de son droit à rétractation ;

- Indiquer les modalités de paiement, de livraison et de taxation ainsi que la validité de l'offre et du prix.

L'acheteur en distribuant en ligne s'engage à respecter la législation spécifique à la vente sur Internet et à la réglementation applicable en général. Il s'engage à faire des offres transparentes au consommateur, apporter conseil et assistance au consommateur, et à avoir un service après-vente.

6- REGLEMENT

- Applicable pour la France :

Nos factures sont payables à trente (30) jours date d'émission de facture, net sans escompte. Pour les règlements comptants, à savoir reçus sous les dix (10) jours maximum de la date de facture, le client a la possibilité de déduire un escompte de zéro unité et cinq dixièmes pourcent (0.50%). Au-delà de l'en-cours de facturation autorisé par nous, et modifiable à tout moment, nos factures sont payables par avance.

- Applicable pour l'Export :

Les premières commandes sont payables par avance. Tout autre mode de paiement ne peut intervenir qu'après remise des références commerciales et bancaires d'usage, et reste sujet à l'accord de notre société d'assurance-crédit. Par la suite, nos factures sont payables à trente (30) jours date d'émission de facture, net sans escompte.

Tout impôt, taxe, droit ou autre prestation à payer en application des règlements français ou ceux d'un pays importateur ou d'un pays de transit sont à la charge du client.

- Applicable pour la France et l'Export :

Les commandes résultant d'une fabrication spéciale, réalisées sur plan, seront payables d'avance pour un tiers (1/3) de leur montant à titre d'acompte.

En cas de non-respect d'une échéance et de retard de paiement, toutes les sommes dues deviennent immédiatement exigibles et toutes les commandes en cours sont suspendues.

De plus, au regard des termes de l'article L.441-10 du Code de commerce, l'acheteur est redevable de plein droit de pénalités calculées sur les montants dus par l'application d'un taux égal à trois (3) fois le taux d'intérêt légal en vigueur au jour de son exigibilité augmenté de 10%. En vertu de l'article L.441-10 al 5 du Code de commerce et en application de l'article D.441-5 du Code de commerce, une indemnité forfaitaire pour frais de recouvrement de quarante (40) Euros est due de plein droit par l'acheteur dès le premier jour de retard. Si les frais de recouvrement exposés sont supérieurs, une indemnisation complémentaire sur justification pourra être demandée par la société.

Si, suite à un accord particulier, la date de paiement mentionnée sur la facture est postérieure au délai indiqué dans les conditions générales de vente, c'est la date portée sur la facture qui est prise en compte.

Toutes les conditions particulières s'entendent sous couvert des garanties accordées par les assurances contractées.

En cas de défaut de paiement, quarante-huit (48) heures après une mise en demeure adressée par LRAR restée infructueuse, la vente sera résiliée de plein droit si bon nous semble et nous pourrions demander, en fonction, la restitution des produits, sans préjudice de tous autres dommages et intérêts. La résolution frapperait non seulement la commande en cause, mais aussi, toutes les commandes impayées antérieures, qu'elles soient livrées ou en cours de livraison et que leur paiement soit dû ou non.

Au cas de paiement par effet de commerce, le défaut de retour de l'effet dans les délais prévus, sera considéré comme un refus d'acceptation assimilable à un défaut de paiement. Toute détérioration du crédit du client pourra justifier l'exigence de garanties ou d'un règlement par avance, avant exécution des commandes reçues. En aucun cas les paiements ne peuvent être suspendus ni faire l'objet d'une quelconque compensation sans un accord écrit et préalable de la société DE BUYER.

7- PORT ET EMBALLAGE, ASSURANCE, LIVRAISON

Même pour les envois FRANCO, les marchandises voyagent toujours sous risques et périls de l'acheteur à qui il appartient de vérifier les marchandises à l'arrivée, et d'exercer s'il y a lieu tous recours, par lettre recommandée avec accusé de réception, contre les transporteurs, qui sont seuls responsables des avaries, vols, pertes, ou retards.

L'acheteur est spécialement tenu de vérifier l'état apparent des marchandises lors de la livraison. S'agissant des pertes et avaries constatées, l'acheteur doit adresser ses réclamations au transporteur conformément aux articles L 133-3 et suivants du code de commerce, par lettre recommandée avec A.R. dans les 3 jours de la livraison, avec copie à la société DE BUYER. Aucune réclamation ne pourra être valablement acceptée en cas de non-respect de ces formalités par l'acheteur. Nos délais de livraison sont donnés à titre indicatif seulement et ne courent qu'après la commande ferme et définitive. La société DE BUYER s'efforce de les respecter. Les retards ne peuvent en aucun cas justifier l'annulation totale ou partielle de la commande, ni donner droit à retenue ou à paiement de dommages intérêts.

La société DE BUYER ne sera en aucun cas responsable des dommages directs et indirects, quels qu'ils soient, pouvant résulter du passivement des délais de livraison.

Les risques de perte ou de détérioration des produits et tout risque de responsabilité lié à l'existence ou l'utilisation des produits se transmettent au client dès leur expédition. Le client s'engage donc à souscrire toute assurance pour couvrir les produits contre tout risque notamment d'incendie, de vol, et de dommages des eaux.

À défaut d'instructions d'expédition particulières par le client, DE BUYER pourra faire effectuer le transport par le transporteur de son choix sans que sa responsabilité puisse être engagée.

En outre, en cas d'interruption du travail pour cas de force majeure tels que définis ci-après, les marchés sont suspendus et notre responsabilité est gérée.

8- RECLAMATIONS ET RETOUR DE MARCHANDISE

Nous n'acceptons aucun retour d'office. Les retours de marchandises ne sont autorisés qu'après acceptation écrite de notre part, et circuleront FRANCO. Ils ne porteront que sur des marchandises livrées depuis moins de vingt (20) jours ouvrés. Ils donneront lieu, après analyse et décision de notre service qualité, à un remplacement du produit reconnu défectueux par DE BUYER ou à un avoir qui sera délivré par rapport au prix net facturé.

Pour tout retour de marchandises dû à une erreur du client quant à la quantité commandée, le code (le numéro de référence mentionné sur l'ordre faisant foi), nous effectuerons une décade de trente pourcent (30%) de la valeur d'achat de la marchandise retournée pour frais de restockage et frais de port payés par DE BUYER lors de l'expédition de la marchandise, après vérification quantitative et qualitative des produits.

Restrictions : Dans tous les cas ne seront pas repris :

- Les produits endommagés, utilisés ou stockés dans des conditions défavorables, utilisés de façon anormale, inappropriée ;
- Les fabrications et commandes spéciales, et produits hors catalogues.

Tout type de réclamation devra être signalé par lettre recommandée avec accusé de réception dans un délai maximum de huit (8) jours ouvrés après la date de livraison.

En cas de réclamation sur des articles, notre responsabilité est limitée au remplacement de la pièce ou de l'article défectueux, sans qu'il y ait lieu d'accorder, en aucun cas et pour quelque raison que ce soit, une indemnité quelconque. Les frais d'envoi des pièces ou articles, et de retour des pièces ou articles défectueux sont à la charge de l'acheteur.

9- CONDITIONS D'UTILISATION DES MARCHANDISES ET DES SUPPORTS PUBLICITAIRES

La société DE BUYER est titulaire de l'ensemble des droits de propriété intellectuelle et industrielle couvrant les produits vendus sous sa marque et/ou toute autre marque utilisée par la société. Les relations commerciales établies entre la société et l'acheteur ne donnent aucun droit à l'acheteur sur les supports publicitaires, marques ou tout autre signe distinctif de la société. Tout usage par l'acheteur de ces éléments doit obtenir l'approbation préalable et écrite de la société DE BUYER.

Le usage par l'acheteur de ces supports publicitaires, marques et signes distinctifs sur des documents commerciaux notamment publicités, catalogues, prospectus, répertoires professionnels, etc., est soumis à l'accord préalable et exprès de la société DE BUYER.

En cas de faute de l'acheteur dans la reproduction ou l'utilisation de l'un de ces éléments, la société DE BUYER sera en droit de réclamer le droit de dommage du préjudice subi.

L'acheteur s'interdit de procéder à des opérations promotionnelles (soldes, discounts, promotion...) sur les produits fournis sous la marque de la société DE BUYER sans l'accord exprès et préalable de cette dernière. Toute vente de marchandises contrefaites et/ou dont le ressemblance avec ceux de la société DE BUYER (produit lui-même, conditionnement, marque, logos...) serait susceptible d'entraîner une confusion dans l'esprit du public est prohibée.

La société DE BUYER se réserve la possibilité de faire évoluer les caractéristiques techniques des produits fournis sans en informer au préalable l'acheteur.

Le non-respect des dispositions ci-dessus pourra entraîner, au choix de la société DE BUYER, la suspension des livraisons, la remise en cause du contrat et/ou une indemnisation du préjudice subi.

10- GARANTIE DE FABRICATION

La garantie des produits est d'un (1) an à compter de la date de livraison.

- Elle s'applique aux produits utilisés dans des conditions normales et appropriées d'utilisation et pour lesquelles un défaut de fabrication est constaté par notre service Qualité ;

- Elle ne s'applique pas pour les produits endommagés, utilisés ou stockés dans des conditions défavorables, utilisés de façon anormale, inappropriée et les fabrications spéciales ;

- Elle ne joue pas pour les vices apparents.

Afin de faire valoir ses droits, l'acheteur devra, sous peine de déchéance de toute action s'y rapportant, informer la société DE BUYER, par écrit, de l'existence des vices dans un délai d'un (1) an à compter de la date de découverte du vice.

La société DE BUYER remplacera ou fera réparer les produits ou pièces sous garantie jugés défectueux par son service qualité. Le remplacement des produits ou pièces défectueux n'aura pas pour effet de prolonger la durée de la garantie ci-dessus fixée.

Les articles spéciaux réalisés suivant des modèles ou dessins fournis par l'acheteur engagent la seule responsabilité de l'acheteur en matière de brevets et de contrefaçon.

Soucieux d'améliorer la qualité nous nous réservons le droit d'apporter à nos articles toutes modifications que nous jugerions nécessaires.

11- CLAUSE PENALE

L'acheteur s'engage à verser, à titre de clause pénale, conformément à l'article 1231-5 du Code civil, une indemnité forfaitaire de quinze pourcent (15%) HT du contrat, pour le cas où il n'exécute pas l'une quelconque des obligations mises à sa charge. La pénalité est indivisible et acquise à la société DE BUYER quand bien même ce dernier solliciterait la résolution du contrat. La présente clause n'interdit pas à la société DE BUYER de demander en justice l'indemnisation de la totalité du préjudice que lui causerait l'inexécution de ce contrat. Le montant de la clause pénale.

12- RESERVE DE PROPRIÉTÉ

En cas de défaut de paiement par le client de tout ou partie du prix de la commande, la société DE BUYER se réserve, usqu'au complet paiement, un droit de propriété sur les produits vendus, lui permettant de reprendre possession desdits produits. Tout acompte versé par le client restera acquis à la société DE BUYER à titre d'indemnisation forfaitaire, sans préjudice de toutes autres actions qu'il serait en droit d'intenter de ce fait à l'encontre du client. En conséquence, le transfert de propriété des produits, au profit de l'acheteur, ne sera réalisé qu'après complet paiement du prix par ce dernier, et ce quelle que soit la date de livraison desdits produits.

13- FORCE MAJEURE

La société DE BUYER est libre et de plein droit de ses obligations si les conditions de paiement n'ont pas été observées par l'acheteur ou en présence d'un cas de force majeure ou d'événements assimilés tels que : conflit de travail, grève totale ou partielle dans la société ou ses fournisseurs, prestataires de services, transporteurs, postes, services publics, suspension ou arrêt d'activité des transporteurs, indisponibilité d'énergie, pénurie de matières premières ou d'emballages, injonction impérative des pouvoirs publics (interdiction d'importer, embargo, confinement, restrictions de circuler, mesures sanitaires...), accidents d'exploitation, bris de machines, explosion, guerre, conflit armé, attentat, tremblement de terre, réquisition, incendie, inondation, accidents d'outilage, défaillance ou carence d'un fournisseur ou sous-traitant, pandémie ou pandémie connue ou non au cours de la conclusion du contrat, maladie des salariés, mesures sanitaires exceptionnelles impactant la production. La société DE BUYER tiendra l'acheteur informé, en temps opportun, des cas ou événements de force majeure ou assimilés.

14- TRAITEMENT DES DONNEES PERSONNELLES

La société DE BUYER, responsable de traitement, met en œuvre des traitements de données personnelles des salariés et/ou des collaborateurs de ses clients dans le cadre de la relation commerciale avec les clients ayant pour finalités la négociation, l'exécution, la gestion, le suivi, la comparaison et l'expédition des commandes, la facturation, la comptabilité et le recouvrement ainsi que l'envoi d'informations commerciales et/ou publicitaires.

Dans les conditions définies par la Loi « Informatique et Libertés » et le Règlement européen sur la protection des données (également désigné « RGPD »), les personnes dont les données sont traitées disposent d'un droit d'accès, de rectification, d'effacement, de minimisation et, le cas échéant, un droit de portabilité des données personnelles les concernant.

Les personnes concernées disposent également du droit de définir des directives générales et particulières définissant la manière dont elles entendent que soient exercés les droits mentionnés ci-dessus, après leur décès.

Dans les conditions prévues par la loi et le RGPD, si la base légale pour le traitement est l'intérêt légitime de la société, sauf pour la société à démontrer l'existence de motifs impérieux et légitimes pour ce traitement qui prévalent sur les intérêts, droits et libertés de la personne concernée, les personnes peuvent également, pour des raisons tenant à leur situation particulière motif légitime, s'opposer au traitement des données les concernant.

Pour exercer ces droits ou pour toute question sur les traitements de données, les personnes concernées peuvent s'adresser à :

Les personnes concernées disposent du droit d'introduire une réclamation auprès de l'autorité de contrôle compétente en France, à savoir la Commission Nationale de l'Informatique et des Libertés (CNIL).
Pour plus d'informations, vous êtes invités à vous reporter à la POLITIQUE DE TRAITEMENT DES DONNEES PERSONNELLES, disponible sur demande.

15- REGLEMENT DES LITIGES ET JURIDICTION

LE TRIBUNAL DE COMMERCE D'EPINAL (88 FRANCE) EST SEUL COMPETENT, y compris en cas de recours en garantie ou de pluralité des défendeurs. Seule la loi française est applicable. La version française de ces conditions générales de vente prévaut sur la version en anglais.

Pour le paiement de nos factures :

Banque CIC F-70 000 VESOUL
IBAN : FR76 3008 7331 8200 0212 9910 108
BIC : CMCIFRPP

Bank KOLB SA F-88500 MIRECOURT
IBAN : FR76 1325 9023 2010 2718 0020 048
BIC : KOLBFR21 - SWIFT : NORDFRPP

DISPLAYS

DISPLAY UNIT 'TOWER'

for a lively boutique with an original, eye-catching display.
Emphasize the value of 'Made in France' !
the TOWER display is available in 4-sided or 6-sided versions, with removable tables and hooks and can be used to display any choice of range:

- PRIMA MATERA
- AFFINITY
- ALCHIMY / MILADY
- ELASTO MOULE
- MINERAL B
- B BOIS

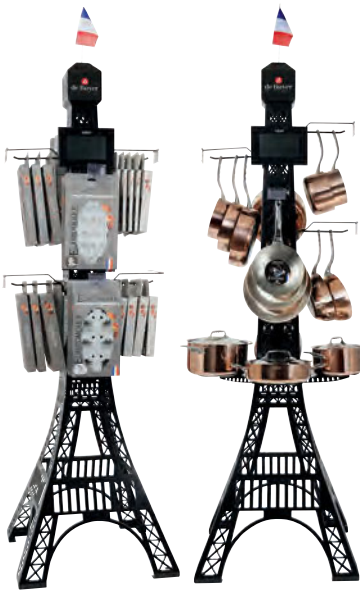

4-SIDE DISPLAY TOWER 5000.09
60 x 60 cm Ht 200 cm - Different compositions available. Option: video screen 5000.96



DISPLAY WOOD AND WHITE

Elegant and practical for setting up a corner dedicated to the brand de Buyer for a high-end presentation.
2 versions: wall display and central display



WALL DISPLAY 5000.20
90 x 47,5 cm HT 210 cm
4 removable shelves - 15 removable hooks
Equipped with a drawer on wheels
LED lighting (transfo 230/12V 60 W)

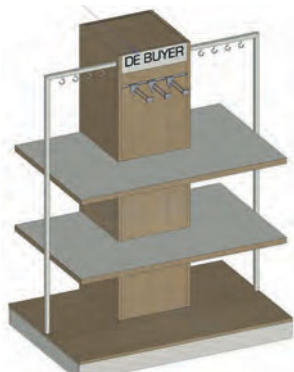

CENTRAL DISPLAY 5000.25
118 x 78 cm HT 155 cm- 2 sides
one side with adjustable shelves
one side with 3 removable hooks on wheels



Grid large display REF.5000.00
255 cm high - 130 cm width - 60 cm deep.
Weight : 68 kg empty - Possible load : 500 kg.
Standard hooks : 27 cm long, ø 8 mm

Consult us for the composition of displays and the conditions to have a display at disposal



de Buyer Industries
25, Faymont - 88340 Le Val d'Ajol - FRANCE
TEL: + 33 (0)3 29 30 66 12
info@debuyer.com - www.debuyer.com
SIRET 403 467 574 00014 TVA FR68 403 467 574

